



**POWER TRANSMISSION
COMPONENTS**



MEGADYNE

Pulegge per cinghie dentate / <i>Timing belt pulleys</i>	3
Pulegge dentate per bussola conica / <i>Timing belt pulleys for taper bushes</i>	13
Pulegge dentate per cinghie passo metrico / <i>Timing belt pulleys metric pitch</i>	21
Pulegge per cinghie dentate, Passo metrico ST per cinghie «AT» / <i>ST timing belt pulleys metric pitch for «AT» belts</i>	29
Pulegge dentate per cinghie con profilo HTD / <i>Timing belt pulleys HTD profile</i>	35
Pulegge dentate con profilo HTD per bussola conica / <i>HTD profile timing belt pulleys for taper bushes</i>	47
Pulegge dentate per cinghie GW / <i>Timing belt pulleys GW</i>	55
Dati tecnici - Flange per pulegge dentate / <i>Technical data - Flanges for timing belt pulleys</i>	62
Piastre di bloccaggio per cinghie / <i>Clamping plates for belts</i>	64
Pulegge trapezoidali PV / <i>PV belt pulleys</i>	67
Pulegge trapezoidali per bussola conica / <i>V-belt pulleys for taper bushes</i>	75
Pulegge trapezoidali monoblocco / <i>V-belt pulleys with solid hub</i>	105
Pulegge trapezoidali per calettatore / <i>V-belt pulleys for locking devices</i>	117
Pulegge variabili / <i>Adjustable pulleys</i>	127
Slitte tendicinghia per motori elettrici / <i>Motor slides for electric motors</i>	130
Giunti dentati SG / <i>Toothed couplings SG</i>	131
Giunti elastici torsionali SG / <i>Torsional flexible couplings SG</i>	137
Giunti SG-HRC / <i>SG-HRC couplings</i>	151
Bussole coniche / <i>Taper bushes</i>	160

PULEGGE PER CINGHIE DENTATE
TIMING BELT PULLEYS



PULEGGE PER CINGHIE DENTATE

TIMING BELT PULLEYS

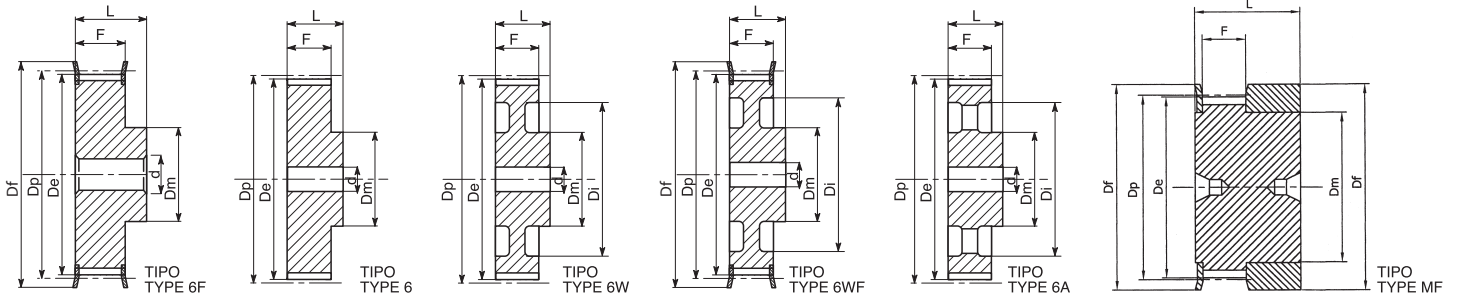

MXL 025 - 0,080" (2,032 mm)

Caratteristiche Features Merkmale Características	Descrizione Description Beschreibung Description Descripción	Tipo Type Typ Type Tipo	Codice flangia Flange code Bordscheiben Typ Code flasque Código brida	N. denti N. of teeth Zähnezahl N. bre de dents Cantidad de dientes	Dp	De	Df	Dm	Di	F	L	Foro stock Stock bore Vor bohrung Alesage en stock Agujero de stock	Peso Weight Gewicht Poids Peso Kg
Aluminio / Aluminium / Aluminium / Aluminium / Aluminio con flangia / with flanges mit Bordscheiben / avec flasques con tapetas	16 MXL 025	MF	FL502	16	10,35	9,84	15,0	8	-	8,5	16	-	0,01
	18 MXL 025	MF	FL503	18	11,64	11,12	16,0	9,5	-	8,5	16	-	0,01
	20 MXL 025	MF	FL503	20	12,94	12,43	16,0	9,5	-	8,5	16	-	0,01
	22 MXL 025	6F	FL504	22	14,23	13,72	17,5	10	-	11,0	16	3	0,01
	24 MXL 025	6F	FL505	24	15,52	15,01	20,0	10	-	11,0	16	3	0,01
	28 MXL 025	6F	FL506	28	18,11	17,60	25,0	11	-	11,0	16	3	0,02
	30 MXL 025	6F	FL506	30	19,40	18,90	25,0	12	-	11,0	16	4	0,03
	32 MXL 025	6F	FL507	32	20,70	20,19	26,0	14	-	11,0	16	4	0,03
	36 MXL 025	6F	FL508	36	23,29	22,78	28,0	16	-	11,0	16	4	0,03
	40 MXL 025	6F	FL509	40	25,87	25,37	32,0	18	-	11,0	16	4	0,04
	42 MXL 025	6F	FL509	42	27,17	26,67	32,0	18	-	11,0	16	5	0,04
44 MXL 025	6F	FL510	44	28,46	27,95	36,0	18	-	11,0	16	5	0,45	
Aluminio / Aluminium / Aluminium / Aluminium / Aluminio senza flangia / without flanges / ohne Bordschei- ben / sans flasques / sin tapetas	48 MXL 025	6	-	48	31,05	30,54	-	20	-	11,0	16	5	0,05
	60 MXL 025	6	-	60	38,81	38,30	-	24	-	11,0	16	5	0,08
	72 MXL 025	6	-	72	46,57	46,06	-	25	-	11,0	16	6	0,11

XL 037 - 1/5" (5,08 mm)

Caratteristiche Features Merkmale Características	Descrizione Description Beschreibung Description Descripción	Tipo Type Typ Type Tipo	Codice flangia Flange code Bordscheiben Typ Code flasque Código brida	N. denti N. of teeth Zähnezahl N. bre de dents Cantidad de dientes	Dp	De	Df	Dm	Di	F	L	Foro stock Stock bore Vor bohrung Alesage en stock Agujero de stock	Peso Weight Gewicht Poids Peso Kg
Aluminio / Aluminium / Aluminium / Aluminium / Aluminio con flangia / with flanges mit Bordscheiben / avec flasques con tapetas	10 XL 037	6F	FL001	10	16,17	15,66	23,0	9,5	-	14,3	20	-	0,02
	11 XL 037	6F	FL001	11	17,79	17,28	23,0	9,5	-	14,3	20	-	0,02
	12 XL 037	6F	FL002	12	19,40	18,90	25,0	10	-	14,3	20	-	0,03
	13 XL 037	6F	FL002	13	21,02	20,51	25,0	10	-	14,3	20	-	0,04
	14 XL 037	6F	FL004	14	22,64	22,13	28,0	15	-	14,3	20	-	0,05
	15 XL 037	6F	FL004	15	24,26	23,75	28,0	15	-	14,3	20	-	0,05
	16 XL 037	6F	FL005	16	25,87	25,36	32,0	16	-	14,3	20	-	0,06
	17 XL 037	6F	FL006	17	27,49	26,98	32,0	20	-	14,3	20	-	0,07
	18 XL 037	6F	FL007	18	29,11	28,60	35,0	20	-	14,3	20	-	0,08
	19 XL 037	6F	FL007	19	30,72	30,22	35,0	20	-	14,3	22	-	0,09
	20 XL 037	6F	FL009	20	32,34	31,83	38,0	24	-	14,3	22	-	0,11
	21 XL 037	6F	FL009	21	33,96	33,45	38,0	24	-	14,3	22	-	0,12
	22 XL 037	6F	FL010	22	35,57	35,07	41,0	25	-	14,3	22	-	0,13
	24 XL 037	6F	FL012	24	38,81	38,30	44,0	30	-	14,3	22	-	0,15
	26 XL 037	6F	FL011	26	42,04	41,53	48,0	30	-	14,3	22	8	0,19
	27 XL 037	6F	FL011	27	43,66	43,15	48,0	34	-	14,3	22	8	0,20
	28 XL 037	6F	FL016	28	45,28	44,77	51,0	34	-	14,3	22	8	0,22
	29 XL 037	6F	FL016	29	46,89	46,39	51,0	34	-	14,3	22	8	0,22
	30 XL 037	6F	FL018	30	48,51	48,00	54,0	38	-	14,3	22	8	0,11
32 XL 037	6F	FL020	32	51,74	51,24	57,0	38	-	14,3	25	8	0,12	
Altern. / Altern. / Altern. Altern. / Altern. senza flangia / without flanges / sans flasques / sin tapetas	34 XL 037	6	-	34	54,98	54,47	-	45	-	14,3	25	8	0,12
	35 XL 037	6	-	35	56,60	56,09	-	45	-	14,3	25	8	0,13
	36 XL 037	6	-	36	58,21	57,70	-	45	-	14,3	25	8	0,14
	38 XL 037	6	-	38	61,45	60,94	-	45	-	14,3	25	8	0,16
	39 XL 037	6	-	39	63,06	62,56	-	45	-	14,3	25	8	0,17
	40 XL 037	6	-	40	64,68	64,17	-	45	-	14,3	25	8	0,17
	41 XL 037	6	-	41	66,30	65,79	-	45	-	14,3	25	8	0,18
	42 XL 037	6	-	42	67,91	67,41	-	45	-	14,3	25	8	0,18
	43 XL 037	6	-	43	69,53	69,02	-	45	-	14,3	25	8	0,19
	44 XL 037	6	-	44	71,15	70,64	-	45	-	14,3	25	8	0,19
	45 XL 037	6W	-	45	72,77	72,26	-	45	61	14,3	25	10	0,19
46 XL 037	6W	-	46	74,38	73,87	-	45	61	14,3	25	10	0,19	
47 XL 037	6W	-	47	76,00	75,49	-	45	61	14,3	25	10	0,19	
48 XL 037	6W	-	48	77,62	77,11	-	45	61	14,3	25	10	0,19	
49 XL 037	6W	-	49	79,23	78,73	-	45	61	14,3	25	10	0,22	
52 XL 037	6W	-	52	84,08	83,58	-	45	67	14,3	25	10	0,22	
56 XL 037	6W	-	56	90,55	90,04	-	45	80	14,3	25	10	0,25	
57 XL 037	6W	-	57	92,17	91,66	-	45	80	14,3	25	10	0,25	
58 XL 037	6W	-	58	93,79	93,28	-	45	80	14,3	25	10	0,25	
59 XL 037	6W	-	59	95,40	94,90	-	45	80	14,3	25	10	0,25	
60 XL 037	6W	-	60	97,02	96,51	-	45	80	14,3	25	10	0,25	
68 XL 037	6W	-	68	109,96	109,45	-	45	100	14,3	25	10	0,30	
69 XL 037	6W	-	69	111,57	111,07	-	45	100	14,3	25	10	0,30	
70 XL 037	6W	-	70	113,19	112,68	-	45	100	14,3	25	10	0,30	
71 XL 037	6W	-	71	114,81	114,30	-	45	100	14,3	25	10	0,30	
72 XL 037	6W	-	72	116,42	115,92	-	45	100	14,3	25	10	0,30	

PULEGGE PER CINGHIE DENTATE TIMING BELT PULLEYS

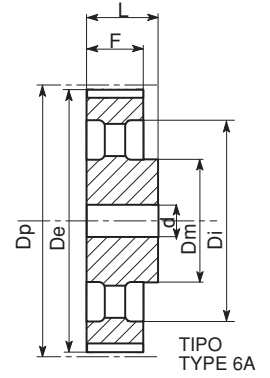
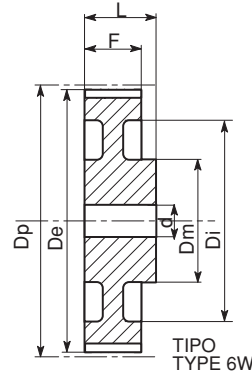
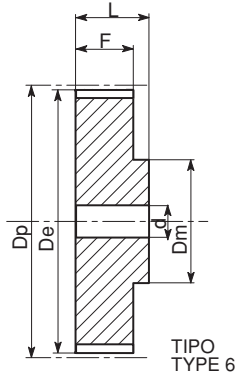
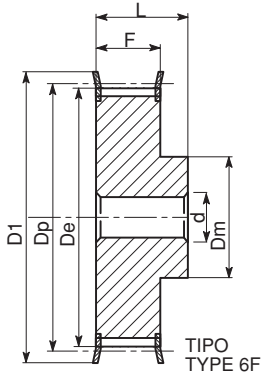

XXH 200 - 1" 1/4 (31,750 mm)

Caratteristiche Features Merkmale Características Características	Descrizione Description Beschreibung Description Descripción	Tipo Type Typ Type Tipo	Codice flangia Flange code Bordscheiben Typ Code flasque Código brida	N. denti N. of teeth Zähnezahl N. bre de dents Cantidad de dientes	Dp	De	Df	Dm	Di	F	L	Foro stock Stock bore Vor bohrung Alesage en stock Agujero de stock	Peso Weight / Gewicht Poids / Peso Kg	
Acciaio / Steel / Stahl Acier / Acero	con flangia / with flanges mit Bordscheiben avec flasques / con tapetas	18XXH200	6F	FL163	18	181,91	178,87	198,0	140	-	64,2	100	28	14,2
		19XXH200	6F	FL164	19	192,02	188,97	205,0	140	-	64,2	100	28	15,8
		20XXH200	6F	FL165	20	202,13	199,08	212,0	150	-	64,2	100	28	17,3
		21XXH200	6F	FL167	21	212,23	209,19	227,0	150	-	64,2	100	28	18,5
		22XXH200	6F	FL169	22	222,34	219,29	240,0	150	-	64,2	100	28	20,0
Ghisa / Cast iron / Grauguss Fonte / Hierro fundido	senza flangia / without flanges ohne Bordscheiben / sans flasques sin tapetas	24XXH200	6	-	24	242,55	239,50	-	150	-	64,2	100	28	23,6
		25XXH200	6W	-	25	252,66	249,61	-	150	196	64,2	100	28	18,0
		26XXH200	6W	-	26	262,76	259,79	-	150	207	64,2	100	28	20,0
		27XXH200	6W	-	27	272,87	269,82	-	150	216	64,2	100	28	24,0
		30XXH200	6W	-	30	303,19	300,14	-	150	247	64,2	100	28	26,0
		34XXH200	6W	-	34	343,62	340,57	-	150	287	64,2	100	28	31,8
		40XXH200	6W	-	40	404,25	401,21	-	150	348	64,2	100	28	43,0
		48XXH200	6W	-	48	485,10	482,06	-	175	429	64,2	100	32	60,4
		60XXH200	6A	-	60	606,38	603,33	-	175	547	64,2	120	32	100,0
	72XXH200	6A	-	72	727,66	724,61	-	175	668	64,2	120	38	130,0	
	90XXH200	6A	-	90	909,57	906,52	-	175	850	64,2	120	38	156,0	

XXH 300 - 1" 1/4 (31,750 mm)

Caratteristiche Features Merkmale Características Características	Descrizione Description Beschreibung Description Descripción	Tipo Type Typ Type Tipo	Codice flangia Flange code Bordscheiben Typ Code flasque Código brida	N. denti N. of teeth Zähnezahl N. bre de dents Cantidad de dientes	Dp	De	Df	Dm	Di	F	L	Foro stock Stock bore Vor bohrung Alesage en stock Agujero de stock	Peso Weight / Gewicht Poids / Peso Kg	
Acciaio / Steel / Stahl Acier / Acero	con flangia / with flanges mit Bordscheiben avec flasques / con tapetas	18XXH300	6F	FL163	18	181,91	178,87	198,0	140	-	91,4	110	28	16,0
		19XXH300	6F	FL164	19	192,02	188,97	205,0	140	-	91,4	110	28	18,4
		20XXH300	6F	FL165	20	202,13	199,08	212,0	150	-	91,4	110	28	20,4
		21XXH300	6F	FL167	21	212,23	209,19	227,0	150	-	91,4	110	28	22,0
		22XXH300	6F	FL169	22	222,34	219,29	240,0	150	-	91,4	110	28	25,0
Ghisa / Cast iron / Grauguss Fonte / Hierro fundido	senza flangia / without flanges ohne Bordscheiben / sans flasques sin tapetas	24XXH300	6	-	24	242,55	239,50	-	150	-	91,4	110	28	29,2
		25XXH300	6W	-	25	252,66	249,61	-	150	196	91,4	110	28	24,6
		26XXH300	6W	-	26	262,76	259,79	-	150	207	91,4	110	28	27,0
		27XXH300	6W	-	27	272,87	269,82	-	150	216	91,4	110	28	29,0
		30XXH300	6W	-	30	303,19	300,14	-	150	247	91,4	110	28	31,0
		34XXH300	6W	-	34	343,62	340,57	-	150	287	91,4	110	28	39,0
		40XXH300	6W	-	40	404,25	401,21	-	150	348	91,4	110	28	45,0
		48XXH300	6W	-	48	485,10	482,06	-	175	429	91,4	110	32	60,0
		60XXH300	6A	-	60	606,38	603,33	-	175	547	91,4	120	32	100,0
	72XXH300	6A	-	72	727,66	724,61	-	175	668	91,4	120	38	135,0	
	90XXH300	6A	-	90	909,57	906,52	-	175	850	91,4	120	38	160,0	

PULEGGE PER CINGHIE DENTATE TIMING BELT PULLEYS

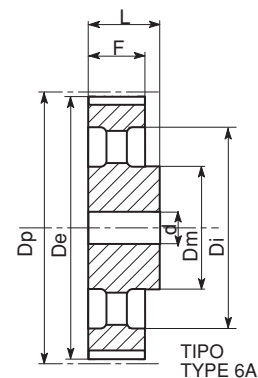
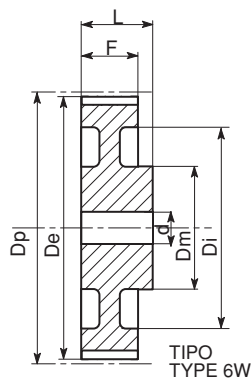
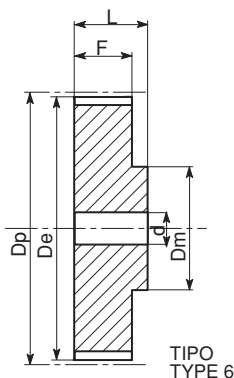
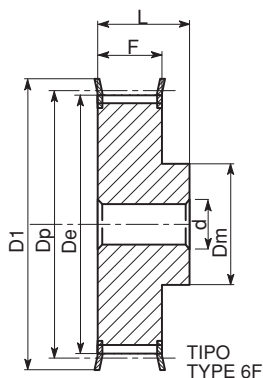

XXH 400 - 1" 1/4 (31,750 mm)

Caratteristiche Features Merkmale Características Características	Descrizione Description Beschreibung Description Descripción	Tipo Type Typ Type Tipo	Codice flangia Flange code Bordscheiben Typ Code flasque Código brida	N. denti N. of teeth Zähnezahl N. bre de dents Cantidad de dientes	Dp	De	Df	Dm	Di	F	L	Foro stock Stock bore Vor bohrung Alesage en stock Agujero de stock	Peso Weight / Gewicht Poids / Peso Kg
Acciaio / Steel / Stahl Acier / Acero	con flangia / with flanges mit Bordscheiben avec flasques / con tapetas	18XXH400	6F	FL163	181,91	178,87	198,0	140	-	120,7	140	32	20,8
		19XXH400	6F	FL164	192,02	188,97	205,0	140	-	120,7	140	32	24,0
		20XXH400	6F	FL165	202,13	199,08	212,0	150	-	120,7	140	32	26,0
		21XXH400	6F	FL167	212,23	209,19	227,0	150	-	120,7	140	32	28,5
		22XXH400	6F	FL169	222,34	219,29	240,0	150	-	120,7	140	32	31,6
Ghisa / Cast iron / Grauguss Fonte / Hierro fundido	senza flangia / without flanges ohne Bordscheiben / sans flasques sin tapetas	24XXH400	6	-	242,55	239,50	-	150	-	120,7	140	32	35,0
		25XXH400	6W	-	252,66	249,61	-	150	196	120,7	140	32	28,0
		26XXH400	6W	-	262,76	259,79	-	150	207	120,7	140	32	32,4
		27XXH400	6W	-	272,87	269,82	-	150	216	120,7	140	32	34,0
		30XXH400	6W	-	303,19	300,14	-	185	247	120,7	140	32	36,0
		34XXH400	6W	-	343,62	340,57	-	185	287	120,7	140	32	47,6
		40XXH400	6W	-	404,25	401,21	-	185	348	120,7	140	32	65,0
		48XXH400	6W	-	485,10	482,06	-	185	429	120,7	140	38	80,5
		60XXH400	6A	-	606,38	603,33	-	185	547	120,7	140	38	108,0
	72XXH400	6A	-	727,66	724,61	-	220	668	120,7	140	38	140,0	
	90XXH400	6A	-	909,57	906,52	-	220	850	120,7	140	38	170,0	

XXH 500 - 1" 1/4 (31,750 mm)

Caratteristiche Features Merkmale Características Características	Descrizione Description Beschreibung Description Descripción	Tipo Type Typ Type Tipo	Codice flangia Flange code Bordscheiben Typ Code flasque Código brida	N. denti N. of teeth Zähnezahl N. bre de dents Cantidad de dientes	Dp	De	Df	Dm	Di	F	L	Foro stock Stock bore Vor bohrung Alesage en stock Agujero de stock	Peso Weight / Gewicht Poids / Peso Kg
Acciaio / Steel / Stahl Acier / Acero	con flangia / with flanges mit Bordscheiben avec flasques / con tapetas	18XXH500	6F	FL163	181,91	178,87	198,0	140	-	145,3	168	32	24,0
		19XXH500	6F	FL164	192,02	188,97	205,0	140	-	145,3	168	32	28,0
		20XXH500	6F	FL165	202,13	199,08	212,0	150	-	145,3	168	32	31,4
		21XXH500	6F	FL167	212,23	209,19	227,0	150	-	145,3	168	32	34,0
		22XXH500	6F	FL169	222,34	219,29	240,0	150	-	145,3	168	32	38,3
Ghisa / Cast iron / Grauguss Fonte / Hierro fundido	senza flangia / without flanges ohne Bordscheiben / sans flasques sin tapetas	24XXH500	6	-	242,55	239,50	-	150	-	145,3	168	32	45,0
		25XXH500	6W	-	252,66	249,61	-	150	196	145,3	168	32	36,0
		26XXH500	6W	-	262,76	259,79	-	150	207	145,3	168	32	37,5
		27XXH500	6W	-	272,87	269,82	-	150	216	145,3	168	32	42,0
		30XXH500	6W	-	303,19	300,14	-	215	247	145,3	168	32	46,8
		34XXH500	6W	-	343,62	340,57	-	215	287	145,3	168	32	57,0
		40XXH500	6W	-	404,25	401,21	-	215	348	145,3	168	32	68,0
		48XXH500	6W	-	485,10	482,06	-	215	429	145,3	168	38	88,8
		60XXH500	6A	-	606,38	603,33	-	240	547	145,3	120	38	99,8
	72XXH500	6A	-	727,66	724,61	-	240	668	145,3	120	38	172,0	
	90XXH500	6A	-	909,57	906,52	-	240	850	145,3	120	38	242,5	

BARRE DENTATE STANDARD STANDARD TOOTHED BARS

Le barre dentate XL e L sono costruite in acciaio C45E e in alluminio 6082 T6, adatte alla anodizzazione. Le barre MXL sono costruite solo in alluminio.

The timing bars XL and L are made of steel C45E and of aluminium 6082 T6, suitable for anodic treatment, whereas the bars MXL are made of aluminium only.

Die stangen XL und L sind aus stahl C45E und aluminium 6082 T6 geeignet fuer anodischen oxydation. Die stangen MXL werden nur aus aluminium gefertigt.

Les barreaux dentes XL et L sont fabriqués en acier C45E et en aluminium 6082 T6, apte au traitement anodi = que, tandis que les barreaux MXL ne sont fabriqués qu'en aluminium.

Las barras dentadas XL y L se construyen en acero C45E y en aluminio 6082 T6 para la oxidacion anodica, mientras que las barras MXL solo se fabrican en aluminio.

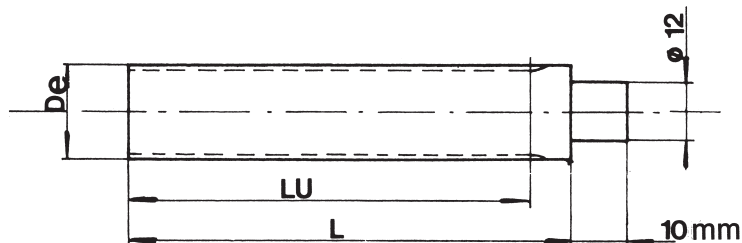

MXL - 0.080" (mm 2,032)

Descrizione Description Beschreibung Descripción	N. denti N. of teeth Zähnezahl N. bre de dents Cantidad de dientes	De	LU	L
MXL 11	11	6,60	50	75
MXL 12	12	7,26	50	75
MXL 13	13	7,90	50	75
MXL 14	14	8,56	50	75
MXL 15	15	9,19	50	75
MXL 16	16	9,83	50	75
MXL 17	17	10,49	50	75
MXL 18	18	11,12	50	75
MXL 19	19	11,78	90	120
MXL 20	20	12,42	90	120
MXL 21	21	13,08	90	120
MXL 22	22	13,72	125	140
MXL 23	23	14,38	125	140
MXL 24	24	15,01	125	140
MXL 25	25	15,67	125	140
MXL 26	26	16,31	125	140
MXL 27	27	16,94	125	140
MXL 28	28	16,70	125	140
MXL 29	29	18,24	125	140
MXL 30	30	18,90	125	140
MXL 32	32	20,19	125	140
MXL 34	34	21,49	125	140
MXL 35	35	22,12	132	140
MXL 36	36	22,78	132	140
MXL 38	38	24,08	132	140
MXL 40	40	25,37	132	140
MXL 42	42	26,67	140	140
MXL 44	44	27,94	140	140
MXL 45	45	28,60	140	140
MXL 48	48	30,53	140	140
MXL 50	50	31,83	140	140
MXL 60	60	38,30	160	160
MXL 64	64	40,89	160	160
MXL 65	65	41,53	160	160
MXL 70	70	44,78	160	160
MXL 72	72	46,05	160	160
MXL 75	75	48,01	160	160
MXL 90	90	57,71	160	160
MXL 110	110	70,64	160	160

XL - 1/5" (mm 5,08)

Descrizione Description Beschreibung Descripción	N. denti N. of teeth Zähnezahl N. bre de dents Cantidad de dientes	De	LU	L
XL 10	10	15,66	125	140
XL 11	11	17,28	125	140
XL 12	12	18,90	125	140
XL 13	13	20,51	125	140
XL 14	14	22,13	132	140
XL 15	15	23,75	132	140
XL 16	16	25,36	140	140
XL 17	17	26,98	140	140
XL 18	18	28,60	140	140
XL 19	19	30,22	140	140
XL 20	20	31,83	140	140
XL 21	21	33,45	160	160
XL 22	22	35,07	160	160
XL 23	23	36,60	160	160
XL 24	24	38,30	160	160
XL 25	25	39,93	160	160
XL 26	26	41,53	160	160
XL 27	27	43,15	160	160
XL 28	28	44,77	160	160
XL 29	29	46,39	160	160
XL 30	30	48,00	160	160
XL 32	32	51,24	160	160
XL 34	34	54,47	160	160
XL 35	35	56,09	160	160
XL 36	36	57,70	160	160
XL 38	38	60,94	160	160
XL 40	40	64,17	160	160
XL 42	42	67,41	160	160
XL 44	44	70,64	160	160
XL 45	45	72,26	160	160
XL 48	48	77,11	160	160
XL 50	50	80,33	160	160
XL 60	60	96,51	160	160
XL 64	64	102,95	160	160
XL 65	65	104,56	160	160
XL 70	70	112,68	160	160
XL 72	72	115,92	160	160

L - 3/8" (mm 9,525)

Descrizione Description Beschreibung Descripción	N. denti N. of teeth Zähnezahl N. bre de dents Cantidad de dientes	De	LU	L
L 10	10	29,56	140	140
L 11	11	32,59	140	140
L 12	12	35,62	160	160
L 13	13	38,65	160	160
L 14	14	41,68	160	160
L 15	15	44,72	160	160
L 16	16	47,75	160	160
L 17	17	50,78	160	160
L 18	18	53,81	160	160
L 19	19	56,84	160	160
L 20	20	59,88	160	160
L 21	21	62,91	160	160
L 22	22	65,94	160	160
L 23	23	68,97	160	160
L 24	24	72,00	160	160
L 27	27	81,10	160	160
L 30	30	90,20	160	160

PULEGGE DENTATE PER BUSSOLA CONICA
TIMING BELT PULLEYS FOR TAPER BUSHES



PULEGGE DENTATE PER BUSSOLA CONICA

TIMING BELT PULLEYS FOR TAPER BUSHES

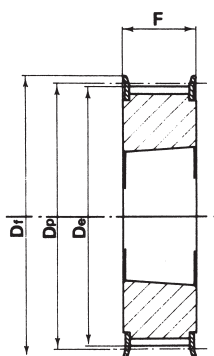

Tipo / Type
3F

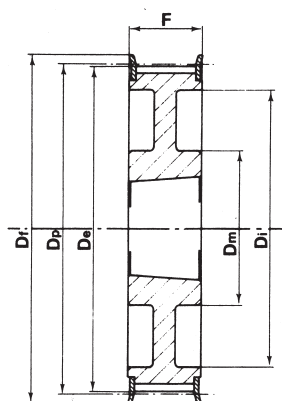

Tipo / Type
3WF

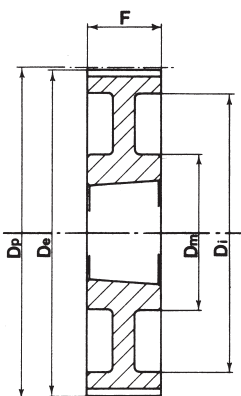

Tipo / Type
3W

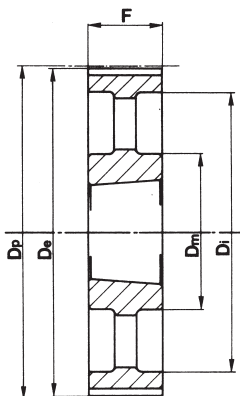

Tipo / Type
3A

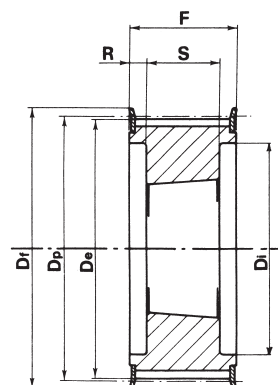

Tipo / Type
4F

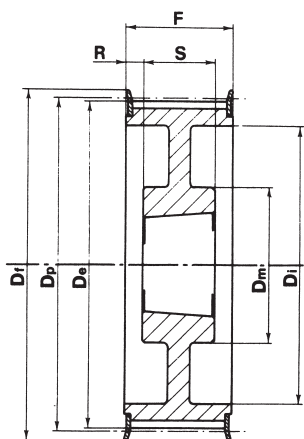

Tipo / Type
4WF

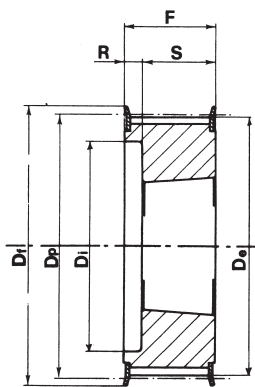

Tipo / Type
5F

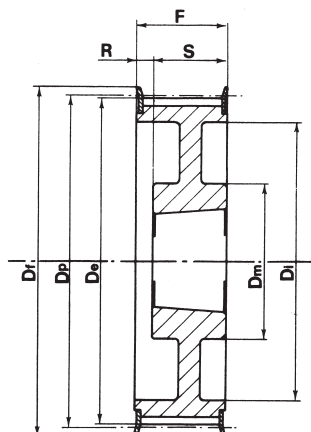

Tipo / Type
5WF

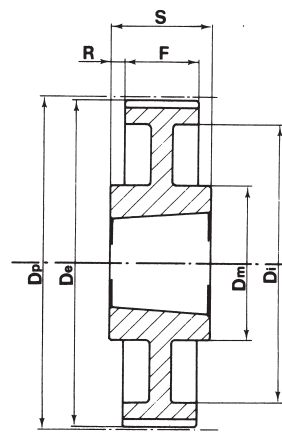

Tipo / Type
7W

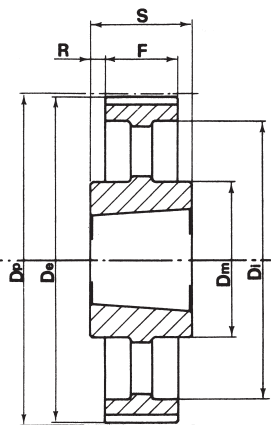

Tipo / Type
7A

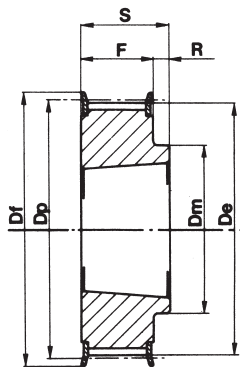

Tipo / Type
8F

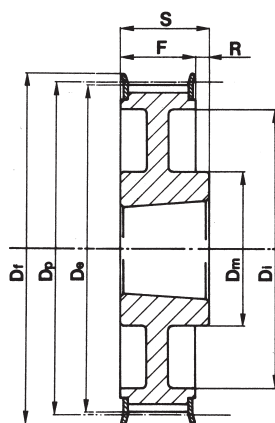

Tipo / Type
8WF

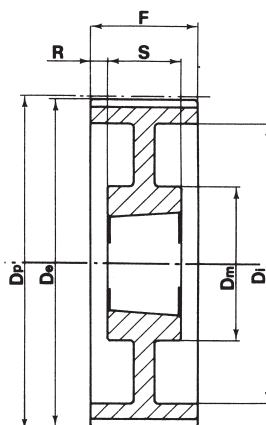

Tipo / Type
9W

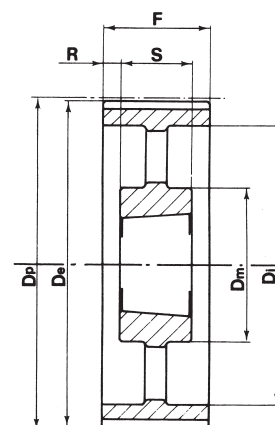

Tipo / Type
9A

PULEGGE DENTATE PER BUSSOLA CONICA TIMING BELT PULLEYS FOR TAPER BUSHES

L 050 - 3/8" (9,525 mm)

Caratteristiche Features Merkmale Características		Descrizione Description Beschreibung Description Descripción	Tipo Type Typ Type Tipo	Codice flangia Flange code Bordscheiben Typ Code flasque Code flasque Código brida	Bussola Bush Buchse Moyeu Casquillo	Foro max. Max. Bore Max. Bohrung Alesage max. Agujero max.	Dp	De	Df	Dm	Di	F	S	R	Peso Weight / Gewicht Poids / Peso Kg
Acciaio / Steel / Stahl Acier / Acero	con flangia / with flanges mit Flanges / avec flasques / con tapetas	18L050	8F	FL058	1108	28	54,57	53,81	60,0	45	-	19,0	22,0	3,0	0,2
		19L050	8F	FL059	1108	28	57,61	56,84	64,0	45	-	19,0	22,0	3,0	0,2
		20L050	8F	FL060	1108	28	60,64	59,88	66,5	48	-	19,0	22,0	3,0	0,2
		21L050	8F	FL061	1108	28	63,67	62,91	70,0	48	-	19,0	22,0	3,0	0,3
		22L050	8F	FL062	1108	28	66,70	65,94	75,0	51	-	19,0	22,0	3,0	0,3
		23L050	8F	FL063	1108	28	69,73	68,97	79,0	54	-	19,0	22,0	3,0	0,4
		24L050	8F	FL063	1108	28	72,77	72,00	79,0	54	-	19,0	22,0	3,0	0,4
		25L050	8F	FL064	1108	28	75,80	75,04	82,5	56	-	19,0	22,0	3,0	0,5
		26L050	8F	FL065	1108	28	78,83	78,07	86,0	60	-	19,0	22,0	3,0	0,5
		27L050	8F	FL065	1108	28	81,86	81,10	86,0	62	-	19,0	22,0	3,0	0,6
		28L050	8F	FL066	1108	28	84,89	84,13	91,0	65	-	19,0	22,0	3,0	0,6
		30L050	8F	FL068	1108	28	90,96	90,20	97,0	70	-	19,0	22,0	3,0	0,8
		32L050	8F	FL070	1108	28	97,02	96,26	102,0	74	-	19,0	22,0	3,0	0,9
		36L050	8F	FL074	1108	28	109,15	108,39	115,0	85	-	19,0	22,0	3,0	1,2
		40L050	8F	FL078	1610	42	121,28	120,51	128,0	88	-	19,0	25,0	6,0	1,5
		44L050	8WF	FL081	1610	42	133,40	132,64	142,0	88	110	19,0	25,0	6,0	1,8
		48L050	8WF	FL085	1610	42	145,53	144,77	150,0	88	120	19,0	25,0	6,0	2,3
Ghisa / Cast iron Grauguss / Fonte Hierro fundido	senza flangia / without flanges ohne Flanschen sans flasques / sin tapetas	60L050	7W	-	1610	42	181,91	181,15	-	92	166	19,0	25,0	3,0	2,0
		72L050	7A	-	1610	42	218,30	217,53	-	92	202	19,0	25,0	3,0	3,0
		84L050	7A	-	1610	42	254,68	253,90	-	92	236	19,0	25,0	3,0	4,0
		96L050	7A	-	2012	50	291,06	290,30	-	106	270	19,0	32,0	6,5	5,5
		120L050	7A	-	2012	50	363,83	363,07	-	106	343	19,0	32,0	6,5	6,8

L 075 - 3/8" (9,525 mm)

Caratteristiche Features Merkmale Características		Descrizione Description Beschreibung Description Descripción	Tipo Type Typ Type Tipo	Codice flangia Flange code Bordscheiben Typ Code flasque Code flasque Código brida	Bussola Bush Buchse Moyeu Casquillo	Foro max. Max. Bore Max. Bohrung Alesage max. Agujero max.	Dp	De	Df	Dm	Di	F	S	R	Peso Weight / Gewicht Poids / Peso Kg
Acciaio / Steel / Stahl Acier / Acero	con flangia / with flanges mit Flanges / avec flasques / con tapetas	18L075	3F	FL058	1108	28	54,57	53,81	60,0	-	-	25,0	25,0	-	0,2
		19L075	3F	FL059	1108	28	57,61	56,84	64,0	-	-	25,0	25,0	-	0,3
		20L075	3F	FL060	1108	28	60,64	59,88	66,5	-	-	25,0	25,0	-	0,3
		21L075	3F	FL061	1108	28	63,67	62,91	70,0	-	-	25,0	25,0	-	0,4
		22L075	3F	FL062	1108	28	66,70	65,94	75,0	-	-	25,0	25,0	-	0,4
		23L075	3F	FL063	1108	28	69,73	68,97	79,0	-	-	25,0	25,0	-	0,4
		24L075	3F	FL063	1108	28	72,77	72,00	79,0	-	-	25,0	25,0	-	0,5
		25L075	3F	FL064	1108	28	75,80	75,04	82,5	-	-	25,0	25,0	-	0,6
		26L075	3F	FL065	1108	28	78,83	78,07	86,0	-	-	25,0	25,0	-	0,6
		27L075	3F	FL065	1108	28	81,86	81,10	86,0	-	-	25,0	25,0	-	0,7
		28L075	3F	FL066	1108	28	84,89	84,13	91,0	-	-	25,0	25,0	-	0,7
		30L075	3F	FL068	1108	28	90,96	90,20	97,0	-	-	25,0	25,0	-	0,9
		32L075	3F	FL070	1108	28	97,02	96,26	102,0	-	-	25,0	25,0	-	1,0
		36L075	3F	FL074	1610	42	109,15	108,39	115,0	-	-	25,0	25,0	-	1,2
		40L075	3F	FL078	1610	42	121,28	120,51	128,0	-	-	25,0	25,0	-	1,7
		44L075	3WF	FL081	1610	42	133,40	132,64	142,0	90	110	25,0	25,0	-	2,1
		48L075	3WF	FL085	1610	42	145,53	144,77	150,0	92	120	25,0	25,0	-	2,5
Ghisa / Cast iron Grauguss / Fonte Hierro fundido	senza flangia / without flanges ohne Flanschen sans flasques / sin tapetas	60L075	3W	-	1610	42	181,91	181,15	-	92	166	25,0	25,0	-	3,0
		72L075	3A	-	1610	42	218,30	217,53	-	92	202	25,0	25,0	-	4,0
		84L075	7A	-	2012	50	254,68	253,90	-	92	236	25,0	32,0	3,5	5,2
		96L075	7A	-	2012	50	291,06	290,30	-	106	270	25,0	32,0	3,5	6,5
		120L075	7A	-	2012	50	363,83	363,07	-	106	343	25,0	32,0	3,5	7,6

PULEGGE DENTATE PER BUSSOLA CONICA TIMING BELT PULLEYS FOR TAPER BUSHES

L 100 - 3/8" (9,525 mm)

Caratteristiche Features Merkmale Características	Descrizione Description Beschreibung Description Descripción	Tipo Type Typ Type Tipo	Codice flangia Flange code Bordscheiben Typ Code flasque Código brida	Bussola Bush Buchse Moyeu Casquillo	Foro max. Max. Bore Max. Bohrung Alesage max. Agujero max.	Dp	De	Df	Dm	Di	F	S	R	Peso Weight / Gewicht Poids / Peso Kg	
Acciaio / Steel / Stahl Acier / Acero	con flangia / with flanges mit Flanges / avec flasques / con tapetas	18L100	5F	FL058	1108	28	54,57	53,81	60,0	-	38	31,0	22,0	9,0	0,2
		19L100	5F	FL059	1108	28	57,61	56,84	64,0	-	38	31,0	22,0	9,0	0,3
		20L100	5F	FL060	1108	28	60,64	59,88	66,5	-	45	31,0	22,0	9,0	0,4
		21L100	5F	FL061	1108	28	63,67	62,91	70,0	-	45	31,0	22,0	9,0	0,4
		22L100	5F	FL062	1108	28	66,70	65,94	75,0	-	48	31,0	22,0	9,0	0,4
		23L100	5F	FL063	1108	28	69,73	68,97	79,0	-	52	32,0	22,0	10,0	0,5
		24L100	5F	FL063	1108	28	72,77	72,00	79,0	-	52	32,0	22,0	10,0	0,6
		25L100	5F	FL064	1108	28	75,80	75,04	82,5	-	54	32,0	22,0	10,0	0,6
		26L100	5F	FL065	1108	28	78,83	78,07	86,0	-	60	32,0	22,0	10,0	0,7
		27L100	5F	FL065	1108	28	81,86	81,10	86,0	-	60	32,0	22,0	10,0	0,8
		28L100	5F	FL066	1108	28	84,89	84,13	91,0	-	65	32,0	22,0	10,0	0,8
		30L100	5F	FL068	1210	32	90,96	90,20	97,0	-	71	32,0	25,0	7,0	0,9
		32L100	5F	FL070	1210	32	97,02	96,26	102,0	-	75	32,0	25,0	7,0	1,0
		36L100	5F	FL074	1610	42	109,15	108,39	115,0	-	86	32,0	25,0	7,0	1,4
		40L100	5F	FL078	1610	42	121,28	120,51	128,0	-	96	32,0	25,0	7,0	1,7
44L100	5WF	FL081	1610	42	133,40	132,64	142,0	90	110	32,0	25,0	7,0	2,3		
48L100	5WF	FL085	1610	42	145,53	144,77	150,0	92	120	32,0	25,0	7,0	2,7		
Ghisa / Cast Iron Grauguss / Fonte Hierro fundido	senza flangia without flanges ohne Flanschen sans flasques sin tapetas	60L100	9W	-	1610	42	181,91	181,15	-	92	166	32,0	25,0	3,5	2,4
		72L100	3A	-	2012	50	218,30	217,53	-	92	202	32,0	32,0	-	4,4
		84L100	3A	-	2012	50	254,68	253,90	-	92	236	32,0	32,0	-	6,0
		96L100	3A	-	2012	50	291,06	290,30	-	106	270	32,0	32,0	-	7,1
		120L100	3A	-	2012	50	363,83	363,07	-	106	343	32,0	32,0	-	8,5

H 100 - 1/2" (12,7 mm)

Caratteristiche Features Merkmale Características	Descrizione Description Beschreibung Description Descripción	Tipo Type Typ Type Tipo	Codice flangia Flange code Bordscheiben Typ Code flasque Código brida	Bussola Bush Buchse Moyeu Casquillo	Foro max. Max. Bore Max. Bohrung Alesage max. Agujero max.	Dp	De	Df	Dm	Di	F	S	R	Peso Weight / Gewicht Poids / Peso Kg	
Acciaio / Steel / Stahl Acier / Acero	con flangia / with flanges mit Flanges / avec flasques / con tapetas	16H100	5F	FL061	1108	28	64,68	63,31	70,0	-	45	31,0	22,0	9,0	0,4
		18H100	5F	FL063	1210	32	72,77	71,39	79,0	-	52	31,0	25,0	6,0	0,5
		19H100	5F	FL064	1210	32	76,81	75,44	82,5	-	56	31,0	25,0	6,0	0,6
		20H100	5F	FL076	1210	32	80,55	79,48	87,0	-	60	31,0	25,0	6,0	0,7
		21H100	5F	FL066	1210	32	84,89	83,52	91,0	-	64	32,0	25,0	7,0	0,8
		22H100	5F	FL067	1210	32	88,94	87,56	94,0	-	67	32,0	25,0	7,0	0,9
		23H100	5F	FL068	1610	42	92,98	91,61	97,0	-	70	32,0	25,0	7,0	0,9
		24H100	5F	FL070	1610	42	97,02	95,65	102,0	-	74	32,0	25,0	7,0	1,0
		25H100	5F	FL071	1610	42	101,06	99,69	106,0	-	77	32,0	25,0	7,0	1,0
		26H100	5F	FL072	1610	42	105,11	103,73	112,0	-	82	32,0	25,0	7,0	1,2
		27H100	5F	FL074	1610	42	109,15	107,78	115,0	-	85	32,0	25,0	7,0	1,3
		28H100	5F	FL075	1610	42	113,19	111,82	120,0	-	90	32,0	25,0	7,0	1,5
		30H100	5F	FL078	1610	42	121,28	119,90	128,0	-	98	32,0	25,0	7,0	1,7
		32H100	5WF	FL080	1610	42	129,36	127,99	135,0	80	106	32,0	25,0	7,0	2,0
		36H100	5WF	FL085	1610	42	145,53	144,16	150,0	92	121	32,0	25,0	7,0	2,7
40H100	5WF	FL090	1610	42	161,70	160,33	168,0	92	138	32,0	25,0	7,0	3,6		
44H100	3WF	FL095	2012	50	177,87	176,50	184,0	106	152	32,0	32,0	-	3,8		
48H100	3WF	FL100	2012	50	194,04	192,67	200,0	106	169	32,0	32,0	-	3,2		
Ghisa / Cast Iron Grauguss / Fonte Hierro fundido	senza flangia without flanges ohne Flanschen sans flasques sin tapetas	60H100	9A	-	2012	50	242,55	241,18	-	92	223	34,0	32,0	1,0	4,8
		72H100	9A	-	2012	50	291,06	289,69	-	92	270	34,0	32,0	1,0	5,7
		84H100	9A	-	2012	50	339,57	338,20	-	92	318	34,0	32,0	1,0	6,8
		96H100	7A	-	2517	60	388,08	386,71	-	106	366	34,0	45,0	5,5	8,2
		120H100	7A	-	2517	60	485,10	483,73	-	106	462	34,0	45,0	5,5	12,1

PULEGGE DENTATE PER BUSSOLA CONICA TIMING BELT PULLEYS FOR TAPER BUSHES

H 150 - 1/2" (12,7 mm)

Caratteristiche Features Merkmale Características	Descrizione Description Beschreibung Description Descripción	Tipo Type Typ Type Tipo	Codice flangia Flange code Bordscheiben Typ Code flasque Código brida	Bussola Bush Buchse Moyeu Casquillo	Foro max. Max. Bore Max. Bohrung Alésage max. Agujero max.	Dp	De	Df	Dm	Di	F	S	R	Peso Weight / Gewicht Poids / Peso Kg		
Acciaio / Steel / Stahl Acier / Acero	con flangia / with flanges mit Flanges / avec flasques / con tapetas		18H150	5F	FL063	1210	32	72,77	71,39	79,0	-	52	45,0	25,0	20,0	0,6
		19H150	5F	FL064	1210	32	76,81	75,44	82,5	-	56	45,0	25,0	20,0	0,7	
		20H150	5F	FL076	1210	32	80,55	79,48	87,0	-	60	45,0	25,0	20,0	0,8	
		21H150	5F	FL066	1210	32	84,89	83,52	91,0	-	64	45,0	25,0	20,0	1,0	
		22H150	5F	FL067	1210	32	88,94	87,56	94,0	-	67	45,0	25,0	20,0	1,2	
		23H150	5F	FL068	1610	42	92,98	91,61	97,0	-	70	45,0	25,0	20,0	1,3	
		24H150	5F	FL070	1610	42	97,02	95,65	102,0	-	74	45,0	25,0	20,0	1,0	
		25H150	5F	FL071	1610	42	101,06	99,69	106,0	-	77	45,0	25,0	20,0	1,2	
		26H150	5F	FL072	1610	42	105,11	103,73	112,0	-	82	45,0	25,0	20,0	1,4	
		27H150	5F	FL074	1610	42	109,15	107,78	115,0	-	85	45,0	25,0	20,0	1,6	
		28H150	5F	FL075	1610	42	113,19	111,82	120,0	-	90	45,0	25,0	20,0	1,8	
		30H150	5F	FL078	1610	42	121,28	119,90	128,0	-	98	45,0	25,0	20,0	2,3	
		32H150	5WF	FL080	1610	42	129,36	127,99	135,0	80	106	45,0	25,0	20,0	2,3	
		36H150	5WF	FL085	1610	42	145,53	144,16	150,0	92	121	45,0	25,0	20,0	3,1	
		40H150	5WF	FL090	1610	42	161,70	160,33	168,0	92	138	45,0	25,0	20,0	4,0	
44H150	5WF	FL095	2012	50	177,87	176,50	184,0	106	152	45,0	32,0	13,0	4,4			
48H150	5WF	FL100	2012	50	194,04	192,67	200,0	106	169	45,0	32,0	13,0	4,8			
Ghisa / Cast Iron Grauguss / Fonte Hierro fundido	senza flangia without flanges ohne flanschen sin tapetas		60H150	9A	-	2012	50	242,55	241,18	-	92	223	46,0	32,0	7,5	5,4
		72H150	9A	-	2012	50	291,06	289,69	-	92	270	46,0	32,0	7,5	6,5	
		84H150	9A	-	2012	50	339,57	338,20	-	92	318	46,0	32,0	7,5	8,4	
		96H150	9A	-	2517	60	388,08	386,71	-	106	366	46,0	45,0	0,5	11,0	
		120H150	9A	-	2517	60	485,10	483,73	-	106	462	46,0	45,0	0,5	14,8	

H 200 - 1/2" (12,7 mm)

Caratteristiche Features Merkmale Características	Descrizione Description Beschreibung Description Descripción	Tipo Type Typ Type Tipo	Codice flangia Flange code Bordscheiben Typ Code flasque Código brida	Bussola Bush Buchse Moyeu Casquillo	Foro max. Max. Bore Max. Bohrung Alésage max. Agujero max.	Dp	De	Df	Dm	Di	F	S	R	Peso Weight / Gewicht Poids / Peso Kg		
Acciaio / Steel / Stahl Acier / Acero	con flangia / with flanges mit Flanges / avec flasques / con tapetas		18H200	5F	FL063	1210	32	72,77	71,39	79,0	-	52	58,0	25,0	33,0	0,8
		19H200	5F	FL064	1210	32	76,81	75,44	82,5	-	56	58,0	25,0	33,0	0,9	
		20H200	5F	FL076	1610	42	80,55	79,48	87,0	-	60	58,0	25,0	33,0	1,0	
		21H200	5F	FL066	1610	42	84,89	83,52	91,0	-	64	58,0	25,0	33,0	1,7	
		22H200	5F	FL067	1610	42	88,94	87,56	94,0	-	67	58,0	25,0	33,0	1,5	
		23H200	5F	FL068	1610	42	92,98	91,61	97,0	-	70	58,0	25,0	33,0	1,8	
		24H200	5F	FL070	1610	42	97,02	95,65	102,0	-	74	58,0	25,0	33,0	1,5	
		25H200	5F	FL071	1610	42	101,06	99,69	106,0	-	77	58,0	25,0	33,0	1,5	
		26H200	5F	FL072	1610	42	105,11	103,73	112,0	-	82	58,0	25,0	33,0	1,8	
		27H200	5F	FL074	1610	42	109,15	107,78	115,0	-	85	58,0	25,0	33,0	1,9	
		28H200	5F	FL075	1610	42	113,19	111,82	120,0	-	90	58,0	25,0	33,0	1,9	
		30H200	5F	FL078	1610	42	121,28	119,90	128,0	-	98	58,0	25,0	33,0	2,3	
		32H200	5F	FL080	2012	50	129,36	127,99	135,0	-	106	58,0	32,0	26,0	3,0	
		36H200	5WF	FL085	2012	50	145,53	144,16	150,0	102	121	58,0	32,0	26,0	3,0	
		40H200	5WF	FL090	2012	50	161,70	160,33	168,0	106	138	58,0	32,0	26,0	3,6	
44H200	5WF	FL095	2012	50	177,87	176,50	184,0	106	152	58,0	32,0	26,0	4,0			
48H200	5WF	FL100	2517	60	194,04	192,67	200,0	119	169	58,0	45,0	13,0	4,6			
Ghisa / Cast Iron Grauguss / Fonte Hierro fundido	senza flangia without flanges ohne flanschen sin tapetas		60H200	9A	-	2517	60	242,55	241,18	-	119	223	60,0	45,0	7,5	7,0
		72H200	9A	-	2517	60	291,06	289,69	-	119	270	60,0	45,0	7,5	8,0	
		84H200	9A	-	2517	60	339,57	338,20	-	119	318	60,0	45,0	7,5	9,0	
		96H200	9A	-	2517	60	388,08	386,71	-	119	366	60,0	45,0	7,5	10,0	
		120H200	9A	-	2517	60	485,10	483,73	-	119	462	60,0	45,0	7,5	13,4	

PULEGGE DENTATE PER BUSSOLA CONICA TIMING BELT PULLEYS FOR TAPER BUSHES

H 300 - 1/2" (12,7 mm)

Caratteristiche Features Merkmale Características	Descrizione Description Beschreibung Description Descripción	Tipo Type Typ Type Tipo	Codice flangia Flange code Bordscheiben Typ Code flasque Código brida	Bussola Bush Buchse Moyeu Casquillo	Foro max. Max. Bore Max. Bohrung Alesage max. Agujero max.	Dp	De	Df	Dm	Di	F	S	R	Peso Weight / Gewicht Poids / Peso Kg	
Acciaio / Steel / Stahl Acier / Acero	con flangia / with flanges mit Flanges / avec flasques / con tapetas	20H300	4F	FL076	1615	42	80,85	79,48	87,0	-	60	84,0	38,0	23,0	1,5
		21H300	4F	FL066	1615	42	84,89	83,52	91,0	-	64	84,0	38,0	23,0	1,2
		22H300	4F	FL067	1615	42	88,94	87,56	94,0	-	67	84,0	38,0	23,0	1,6
		23H300	4F	FL068	1615	42	92,98	91,61	97,0	-	70	84,0	38,0	23,0	1,8
		24H300	4F	FL070	1615	42	97,02	95,65	102,0	-	74	84,0	38,0	23,0	2,0
		25H300	4F	FL071	1615	42	101,06	99,69	106,0	-	77	84,0	38,0	23,0	2,0
		26H300	4F	FL072	1615	42	105,11	103,73	112,0	-	82	84,0	38,0	23,0	2,7
		27H300	4F	FL074	2012	50	109,15	107,78	115,0	-	85	84,0	32,0	26,0	3,0
		28H300	4F	FL075	2012	50	113,19	111,82	120,0	-	90	84,0	32,0	26,0	2,4
		30H300	4F	FL078	2012	50	121,28	119,90	128,0	-	98	84,0	32,0	26,0	2,9
		32H300	4F	FL080	2517	60	129,36	127,99	135,0	-	106	84,0	45,0	19,5	3,3
		36H300	4F	FL085	2517	60	145,53	144,16	150,0	-	121	84,0	45,0	19,5	4,5
		40H300	4F	FL090	2517	60	161,70	160,33	168,0	-	138	84,0	45,0	19,5	6,0
		44H300	9WF	FL095	2517	60	177,87	176,50	184,0	119	152	86,0	45,0	20,5	6,6
48H300	9WF	FL100	2517	60	194,04	192,67	200,0	119	169	86,0	45,0	20,5	7,6		
Ghisa / Cast iron Grauguss / Fonte Hierro fundido	senza flangia without flanges ohne Flanschen sans flasques sin tapetas	60H300	9A	-	2517	60	242,55	241,18	-	119	223	86,0	45,0	20,5	8,4
		72H300	9A	-	2517	60	291,06	289,69	-	119	270	86,0	45,0	20,5	10,4
		84H300	9A	-	2517	60	339,57	338,20	-	119	318	86,0	45,0	20,5	12,5
		96H300	9A	-	3030	75	388,08	386,71	-	150	366	86,0	76,0	5,0	14,2
		120H300	9A	-	3030	75	485,10	483,73	-	150	462	86,0	76,0	5,0	18,8

XH 200 - 7/8" (22,25 mm)

Caratteristiche Features Merkmale Características	Descrizione Description Beschreibung Description Descripción	Tipo Type Typ Type Tipo	Codice flangia Flange code Bordscheiben Typ Code flasque Código brida	Bussola Bush Buchse Moyeu Casquillo	Foro max. Max. Bore Max. Bohrung Alesage max. Agujero max.	Dp	De	Df	Dm	Di	F	S	R	Peso Weight / Gewicht Poids / Peso Kg	
Ghisa / Cast iron Grauguss / Fonte Hierro fundido	con flangia / with flanges mit Flanges / avec flasques / con tapetas	18XH200	5F	FL155	2517	60	127,34	124,55	140,0	-	95	64	45	19,0	
		20XH200	5F	FL157	2517	60	141,49	138,69	155,0	-	110	64	45	19,0	
		22XH200	5F	FL159	2517	60	155,64	152,84	170,0	-	120	64	45	19,0	
		24XH200	5F	FL161	2517	60	169,79	166,99	184,0	-	135	64	45	19,0	
		26XH200	5F	FL163	2517	60	183,94	181,14	198,0	-	150	64	45	19,0	
		28XH200	4WF	FL165	2517	60	198,08	195,29	212,0	120	165	64	45	9,5	
		30XH200	4WF	FL167	2517	60	212,23	209,44	227,0	120	180	64	45	9,5	
		32XH200	4WF	FL169	2517	60	226,38	223,59	240,0	120	195	64	45	9,5	
	40XH200	4WF	FL177	3020	75	282,98	280,18	297,0	160	245	64	51	9,5		
	senza flangia / without flanges ohne Flanschen / sans flasques sin tapetas	48XH200	9W	-	3020	75	339,57	336,78	-	160	300	64	51	6,5	
		60XH200	7A	-	3535	90	424,47	421,67	-	190	385	64	89	12,5	
		72XH200	7A	-	3535	90	509,40	506,56	-	190	470	64	89	12,5	
		84XH200	7A	-	3535	90	594,25	591,46	-	190	555	64	89	12,5	
		96XH200	7A	-	3535	90	679,15	676,35	-	190	640	64	89	12,5	
120XH200		7A	-	3535	90	848,93	846,14	-	190	810	64	89	12,5		

PULEGGE DENTATE PER BUSSOLA CONICA TIMING BELT PULLEYS FOR TAPER BUSHES

XH 300 - 7/8" (22,225 mm)

Caratteristiche Features Merkmale Características	Descrizione Description Beschreibung Description Descripción	Tipo Type Typ Type Tipo	Codice flangia Flange code Bordscheiben Typ Code flasque Código brida	Bussola Bush Buchse Moyeu Casquillo	Foro max. Max. Bore Max. Bohrung Alesage max. Agujero max.	Dp	De	Df	Dm	Di	F	S	R	Peso Weight / Gewicht Poids / Peso Kg	
Ghisa / Cast iron Grauguss / Fonte Hierro fundido	con flangia / with flanges mit Flanges / avec flasques / con tapetas	18XH300	5F	FL155	2517	60	127,34	124,55	140,0	-	95	90	45,0	45,0	
		20XH300	5F	FL157	2517	60	141,49	138,69	155,0	-	110	90	45,0	45,0	
		22XH300	5F	FL159	2517	60	155,64	152,84	170,0	-	120	90	45,0	45,0	
		24XH300	5F	FL161	2517	60	169,79	166,99	184,0	-	135	90	45,0	45,0	
		26XH300	5F	FL163	2517	60	183,94	181,14	198,0	-	150	90	45,0	45,0	
		28XH300	5F	FL165	3020	75	198,08	195,29	212,0	-	165	90	51,0	39,0	
		30XH300	5F	FL167	3020	75	212,23	209,44	227,0	-	180	90	51,0	39,0	
		32XH300	5F	FL169	3020	75	226,38	223,59	240,0	-	195	90	51,0	39,0	
		40XH300	4WF	FL177	3020	75	282,98	280,18	297,0	160	245	90	51,0	19,5	
	senza flangia / without flanges ohne Flanschen / sans flasques sin tapetas	48XH300	9A	-	3020	75	339,57	336,78	-	160	300	90	51,0	19,5	
		60XH300	9A	-	3535	90	424,47	421,67	-	190	385	90	89,0	0,5	
		72XH300	9A	-	3535	90	509,40	506,56	-	190	470	90	89,0	0,5	
		84XH300	7A	-	4040	100	594,25	591,46	-	190	555	90	102,0	6,0	
		96XH300	7A	-	4040	100	679,15	676,35	-	190	640	90	102,0	6,0	
		120XH300	7A	-	4040	100	848,93	846,14	-	190	810	90	102,0	6,0	

XH 400 - 7/8" (22,225 mm)

Caratteristiche Features Merkmale Características	Descrizione Description Beschreibung Description Descripción	Tipo Type Typ Type Tipo	Codice flangia Flange code Bordscheiben Typ Code flasque Código brida	Bussola Bush Buchse Moyeu Casquillo	Foro max. Max. Bore Max. Bohrung Alesage max. Agujero max.	Dp	De	Df	Dm	Di	F	S	R	Peso Weight / Gewicht Poids / Peso Kg	
Ghisa / Cast iron Grauguss / Fonte Hierro fundido	con flangia / with flanges mit Flanges / avec flasques / con tapetas	18XH400	5F	FL155	2517	60	127,34	124,55	140,0	-	95	119	45,0	74,0	
		20XH400	5F	FL157	2517	60	141,49	138,69	155,0	-	110	119	45,0	74,0	
		22XH400	5F	FL159	2517	60	155,64	152,84	170,0	-	120	119	45,0	74,0	
		24XH400	5F	FL161	3020	75	169,79	166,99	184,0	-	135	119	51,0	68,0	
		26XH400	5F	FL163	3020	75	183,94	181,14	198,0	-	150	119	51,0	68,0	
		28XH400	5F	FL165	3020	75	198,08	195,29	212,0	-	165	119	51,0	68,0	
		30XH400	5F	FL167	3020	75	212,23	209,44	227,0	-	180	119	51,0	68,0	
		32XH400	5F	FL169	3020	75	226,38	223,59	240,0	-	195	119	51,0	68,0	
		40XH400	4WF	FL177	3535	90	282,98	280,18	297,0	160	245	119	89,0	15,0	
	senza flangia / without flanges ohne Flanschen / sans flasques sin tapetas	48XH400	9W	-	3535	90	339,57	336,78	-	160	300	119	89,0	15,0	
		60XH400	9A	-	4040	100	424,47	421,67	-	190	385	119	102,0	8,5	
		72XH400	9A	-	4040	100	509,40	506,56	-	190	470	119	102,0	8,5	
		84XH400	9A	-	4040	100	594,25	591,46	-	190	555	119	102,0	8,5	
		96XH400	9A	-	4040	100	679,15	676,35	-	190	640	119	102,0	8,5	
		120XH400	9A	-	4040	100	848,93	846,14	-	190	810	119	102,0	8,5	

PULEGGE DENTATE PER CINGHIE PASSO METRICO
TIMING BELT PULLEYS METRIC PITCH



ISTRUZIONI PER L'IDENTIFICAZIONE E LA CLASSIFICAZIONE DELLE PULEGGE A PASSO METRICO

INSTRUCTIONS FOR THE IDENTIFICATION AND CLASSIFICATION OF TIMING BELT PULLEYS METRIC PITCH

Esempio:
ALTEZZA 40 T 10/32-2

40 = Larghezza totale della puleggia 40 mm (L)

T10 = Passo 10 mm

30 = N. denti

2 = N. della flangia

Materiale:
alluminio 6082 T6
UNI 9006/4 adatto al
trattamento anodico

Example:
PULLEY 40 T 10/32-2

40 = Total width of pulley 40 mm (L)

T10 = Pitch 10 mm

30 = No. of teeth

2 = No. of flanges

Material:
aluminium 6082 T6
UNI 9006/4 suitable for
anodic treatment

Beispiel:
SCHEIBE 40 T 10/32-2

40 = Gesamtbreite der Scheibe 40 mm (L)

T10 = Teilung 10 mm

30 = Zähnezahl

2 = Anzahl der Bordscheiben

Werkstoff:
Aluminium 6082 T6
UNI 9006/4 geeignet für
anodischen oxydation

Exemple:
POULIE 40 T 10/32-2

40 = Largeur totale de la poulie 40 mm (L)

T10 = Pas 10 mm

30 = N. de dents

2 = N. de flasques

Matière:
aluminium 6082 T6
UNI 9006/4 apte au
traitement anodique

Ejemplo:
POLEA 40 T 10/32-2

40 = Ancho total de la polea 40 mm (L)

T10 = Paso 10 mm

30 = Cantidad de dientes

2 = Cantidad de tapetas

Material:
aluminio 6082 T6
UNI 9006/4 apto para la
oxidación anódica

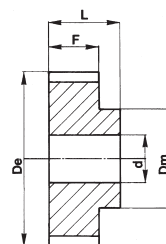
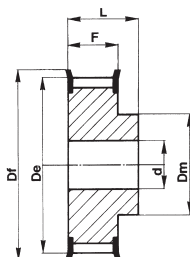
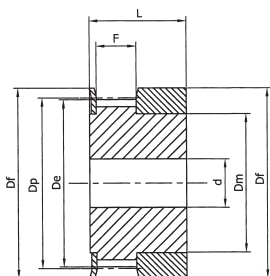

Materiale:
alluminio 6082 T6
UNI 9006/4 adatto al
trattamento anodico

Material:
aluminium 6082 T6
UNI 9006/4 suitable for
anodic treatment

Werkstoff:
Aluminium 6082 T6
UNI 9006/4 geeignet für
anodischen oxydation

Matière:
aluminium 6082 T6
UNI 9006/4 apte au
traitement anodique

Material:
aluminio 6082 T6
UNI 9006/4 apto para la
oxidacion anodica

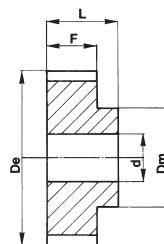
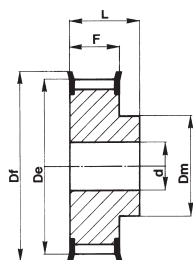

T 5

(Passo 5 mm) per cinghia larghezza 16 mm (Pitch 5 mm) for belt width 16 mm (Teilung 5 mm) für Riemenbreite 16 mm (Pas 5 mm) pour courroies largeur 16 mm (Paso 5 mm) para correas ancho 16 mm

27T5/10-2	6F	FL003	10	15,92	15,05	19,5	8	21	27	4	0,016	
27T5/12-2	6F	FL001	12	19,10	18,25	23,0	11	21	27	4	0,022	
27T5/14-2	6F	FL002	14	22,29	21,45	25,0	13	21	27	4	0,026	
27T5/15-2	6F	FL004	15	23,88	23,05	28,0	16	21	27	6	0,029	
27T5/16-2	6F	FL005	16	25,47	24,60	32,0	18	21	27	6	0,035	
27T5/18-2	6F	FL006	18	28,65	27,80	32,0	10	21	27	6	0,043	
27T5/19-2	6F	FL008	19	30,25	29,40	36,0	20	21	27	6	0,049	
27T5/20-2	6F	FL008	20	31,83	31,00	36,0	22	21	27	6	0,053	
27T5/22-2	6F	FL009	22	35,02	34,15	38,0	23	21	27	6	0,065	
27T5/24-2	6F	FL013	24	38,21	37,40	42,0	24	21	27	6	0,076	
27T5/25-2	6F	FL012	25	39,80	38,95	44,0	26	21	27	6	0,078	
27T5/26-2	6F	FL012	26	41,39	40,60	44,0	26	21	27	6	0,080	
27T5/27-2	6F	FL011	27	42,98	42,20	48,0	30	21	27	8	0,090	
27T5/28-2	6F	FL011	28	44,58	43,75	48,0	32	21	27	8	0,095	
27T5/30-2	6F	FL016	30	47,76	46,95	51,0	34	21	27	8	0,105	
27T5/32-2	6F	FL018	32	50,94	50,10	54,0	38	21	27	8	0,123	
27T5/36-2	6F	FL023	36	57,31	56,45	64,0	38	21	27	8	0,160	
27T5/40-2	6F	FL024	40	63,66	62,85	66,5	40	21	27	8	0,193	
27T5/42-2	6F	FL026	42	66,86	66,00	70,0	40	21	27	8	0,200	
27T5/44-0	6	-	44	70,05	69,20	-	45	21	27	8	0,300	
27T5/48-0	6	-	48	76,42	75,55	-	50	21	27	8	0,280	
27T5/60-0	6	-	60	95,52	94,65	-	65	21	27	8	0,430	

(Passo 5 mm) per cinghia larghezza 25 mm (Pitch 5 mm) for belt width 25 mm (Teilung 5 mm) für Riemenbreite 25 mm (Pas 5 mm) pour courroies largeur 25 mm (Paso 5 mm) para correas ancho 25 mm

36T5/10-2	6F	FL003	10	15,92	15,05	19,5	8	30	36	4	0,023	
36T5/12-2	6F	FL001	12	19,10	18,25	23,0	11	30	36	4	0,031	
36T5/14-2	6F	FL002	14	22,29	21,45	25,0	13	30	36	4	0,037	
36T5/15-2	6F	FL004	15	23,88	23,05	28,0	16	30	36	6	0,041	
36T5/16-2	6F	FL005	16	25,47	24,60	32,0	18	30	36	6	0,050	
36T5/18-2	6F	FL006	18	28,65	27,80	32,0	10	30	36	6	0,061	
36T5/19-2	6F	FL008	19	30,25	29,40	36,0	20	30	36	6	0,070	
36T5/20-2	6F	FL008	20	31,83	31,00	36,0	22	30	36	6	0,076	
36T5/22-2	6F	FL009	22	35,02	34,15	38,0	23	30	36	6	0,090	
36T5/24-2	6F	FL013	24	38,21	37,40	42,0	24	30	36	8	0,109	
36T5/25-2	6F	FL012	25	39,80	38,95	44,0	26	30	36	8	0,116	
36T5/26-2	6F	FL012	26	41,39	40,60	44,0	26	30	36	8	0,100	
36T5/27-2	6F	FL011	27	42,98	42,20	48,0	30	30	36	8	0,128	
36T5/28-2	6F	FL011	28	44,58	43,75	48,0	32	30	36	8	0,135	
36T5/30-2	6F	FL016	30	47,76	46,95	51,0	34	30	36	8	0,150	
36T5/32-2	6F	FL018	32	50,94	50,10	54,0	38	30	36	8	0,176	
36T5/36-2	6F	FL023	36	57,31	56,45	64,0	38	30	36	8	0,230	
36T5/40-2	6F	FL024	40	63,66	62,85	66,5	40	30	36	8	0,276	
36T5/42-2	6F	FL026	42	66,86	66,00	70,0	40	30	36	8	0,300	
36T5/44-0	6	-	44	70,05	69,20	-	45	30	36	8	0,300	
36T5/48-0	6	-	48	76,42	75,55	-	50	30	36	8	0,400	
36T5/60-0	6	-	60	95,52	94,65	-	65	30	36	8	0,614	

PULEGGE DENTATE PER CINGHIE PASSO METRICO TIMING BELT PULLEYS METRIC PITCH

Materiale:
alluminio 6082 T6
UNI 9006/4 adatto al
trattamento anodico

Material:
aluminium 6082 T6
UNI 9006/4 suitable for
anodic treatment

Werkstoff:
Aluminium 6082 T6
UNI 9006/4 geeignet für
anodischen oxydation

Matière:
aluminium 6082 T6
UNI 9006/4 apte au
traitement anodique

Material:
aluminio 6082 T6
UNI 9006/4 apto para la
oxidacion anodica

**Tipo / Type
6F**

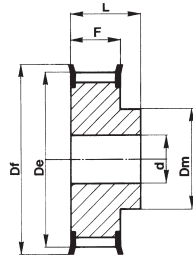

**Tipo / Type
6**

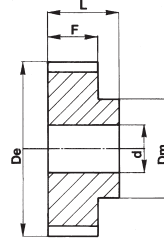

T 10

(Passo 10 mm)
per cinghia larghezza 16 mm

(Pitch 10 mm)
for belt width 16 mm

(Teilung 10 mm)
für Riemenbreite 16 mm

(Pas 10 mm)
pour courroies largeur 16 mm

(Paso 10 mm)
para correas ancho 16 mm

Descrizione / Description Beschreibung / Description Descripción	Tipo Type / Typ Type / Tipo	Codice flangia Flange code / Bordscheiben Typ Code flasque / Código brida	N. denti N. of teeth / Zähnezahl N. bre de dents Cantidad de dientes	Dp	De	Df	Dm	F	L	d	Peso / Weight Gewicht / Poids / Peso Kg
31T10/12-2	6F	FL013	12	38,20	36,35	42,0	28	21	31	6	0,076
31T10/14-2	6F	FL011	14	44,56	42,70	48,0	32	21	31	8	0,104
31T10/15-2	6F	FL016	15	47,75	45,90	51,0	32	21	31	8	0,116
31T10/16-2	6F	FL018	16	50,93	49,10	54,0	35	21	31	8	0,134
31T10/18-2	6F	FL021	18	57,29	55,45	60,0	40	21	31	8	0,167
31T10/19-2	6F	FL024	19	60,48	58,65	66,5	44	21	31	8	0,184
31T10/20-2	6F	FL024	20	63,66	61,80	66,5	46	21	31	8	0,208
31T10/22-2	6F	FL027	22	70,03	68,20	75,0	52	21	31	8	0,240
31T10/24-2	6F	FL029	24	76,39	74,55	83,0	58	21	31	8	0,288
31T10/25-2	6F	FL029	25	79,58	77,70	83,0	60	21	31	8	0,295
31T10/26-2	6F	FL031	26	82,76	80,90	87,0	60	21	31	8	0,310
31T10/27-2	6F	FL032	27	85,95	84,10	91,0	60	21	31	8	0,364
31T10/28-2	6F	FL033	28	89,12	87,25	93,0	60	21	31	8	0,441
31T10/30-2	6F	FL035	30	95,49	93,65	97,0	60	21	31	8	0,493
31T10/32-2	6F	FL038	32	101,86	100,00	106,0	65	21	31	10	0,623
31T10/36-2	6F	FL043	36	114,59	112,75	119,0	70	21	31	10	0,767
31T10/40-2	6F	FL047	40	127,32	125,45	131,0	80	21	31	10	0,950
31T10/44-0	6	-	44	140,05	138,20	-	88	21	31	10	1,090
31T10/48-0	6	-	48	152,78	150,95	-	95	21	31	16	1,704
31T10/60-0	6	-	60	190,98	189,10	-	110	21	31	16	1,704

(Passo 10 mm)
per cinghia larghezza 25 mm

(Pitch 10 mm)
for belt width 25 mm

(Teilung 10 mm)
für Riemenbreite 25 mm

(Pas 10 mm)
pour courroies largeur 25 mm

(Paso 10 mm)
para correas ancho 25 mm

Descrizione / Description Beschreibung / Description Descripción	Tipo Type / Typ Type / Tipo	Codice flangia Flange code / Bordscheiben Typ Code flasque / Código brida	N. denti N. of teeth / Zähnezahl N. bre de dents Cantidad de dientes	Dp	De	Df	Dm	F	L	d	Peso / Weight Gewicht / Poids / Peso Kg
40T10/12-2	6F	FL013	12	38,20	36,35	42,0	28	30	40	6	0,099
40T10/14-2	6F	FL011	14	44,56	42,70	48,0	32	30	40	8	0,134
40T10/15-2	6F	FL016	15	47,75	45,90	51,0	32	30	40	8	0,152
40T10/16-2	6F	FL018	16	50,93	49,10	54,0	35	30	40	8	0,176
40T10/18-2	6F	FL021	18	57,29	55,45	60,0	40	30	40	8	0,224
40T10/19-2	6F	FL024	19	60,48	58,65	66,5	44	30	40	8	0,247
40T10/20-2	6F	FL024	20	63,66	61,80	66,5	46	30	40	8	0,276
40T10/22-2	6F	FL027	22	70,03	68,20	75,0	52	30	40	8	0,310
40T10/24-2	6F	FL029	24	76,39	74,55	83,0	58	30	40	8	0,392
40T10/25-2	6F	FL029	25	79,58	77,70	83,0	60	30	40	8	0,422
40T10/26-2	6F	FL031	26	82,76	80,90	87,0	60	30	40	8	0,480
40T10/27-2	6F	FL032	27	85,95	84,10	91,0	60	30	40	8	0,536
40T10/28-2	6F	FL033	28	89,12	87,25	93,0	60	30	40	8	0,590
40T10/30-2	6F	FL035	30	95,49	93,65	97,0	60	30	40	8	0,640
40T10/32-2	6F	FL038	32	101,86	100,00	106,0	65	30	40	10	0,693
40T10/36-2	6F	FL043	36	114,59	112,75	119,0	70	30	40	10	0,873
40T10/40-2	6F	FL047	40	127,32	125,45	131,0	80	30	40	10	1,067
40T10/44-0	6	-	44	140,05	138,20	-	88	30	40	10	1,310
40T10/48-0	6	-	48	152,78	150,95	-	95	30	40	16	1,516
40T10/60-0	6	-	60	190,98	189,10	-	110	30	40	16	2,339

PULEGGE DENTATE PER CINGHIE PASSO METRICO TIMING BELT PULLEYS METRIC PITCH

Materiale:
alluminio 6082 T6
UNI 9006/4 adatto al
trattamento anodico

Material:
aluminium 6082 T6 UNI
9006/4 suitable for anodic
treatment

Werkstoff:
Aluminium 6082 T6
UNI 9006/4 geeignet für
anodischen oxydation

Matière:
aluminium 6082 T6
UNI 9006/4 apte au
traitement anodique

Material:
aluminio 6082 T6
UNI 9006/4 apto para la
oxidacion anodica

Tipo / Type
6F

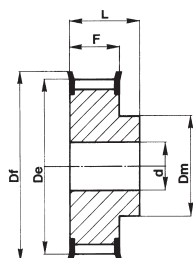

Tipo / Type
6

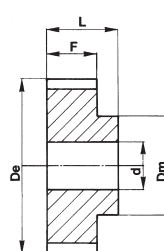

T 10

(Passo 10 mm)
per cinghia larghezza 32 mm

(Pitch 10 mm)
for belt width 32 mm

(Teilung 10 mm)
für Riemenbreite 32 mm

(Pas 10 mm)
pour courroies largeur 32 mm

(Paso 10 mm)
para correas ancho 32 mm

Descrizione / Description Beschreibung / Description Descripción	Tipo Type / Typ Tipo / Tipo	Codice flangia Flange code / Bordscheiben Typ Code flasque / Código brida	N. denti N. of teeth / Zähnezahl N. bre de dents Cantidad de dientes	Dp	De	Df	Dm	F	L	d	Peso / Weight Gewicht / Poids / Peso Kg
47T10/18-2	6F	FL021	18	57,29	55,45	60,0	40	37	47	10	0,253
47T10/19-2	6F	FL024	19	60,48	58,65	66,5	44	37	47	10	0,286
47T10/20-2	6F	FL024	20	63,66	61,80	66,5	46	37	47	12	0,322
47T10/22-2	6F	FL027	22	70,03	68,20	75,0	52	37	47	12	0,393
47T10/24-2	6F	FL029	24	76,39	74,55	83,0	58	37	47	12	0,475
47T10/25-2	6F	FL029	25	79,58	77,70	83,0	60	37	47	12	0,527
47T10/26-2	6F	FL031	26	82,76	80,90	87,0	60	37	47	12	0,564
47T10/27-2	6F	FL032	27	85,95	84,10	91,0	60	37	47	12	0,602
47T10/28-2	6F	FL033	28	89,12	87,25	93,0	60	37	47	12	0,642
47T10/30-2	6F	FL035	30	95,49	93,65	97,0	60	37	47	12	0,740
47T10/32-2	6F	FL038	32	101,86	100,00	106,0	65	37	47	12	0,844
47T10/36-2	6F	FL043	36	114,59	112,75	119,0	70	37	47	16	1,063
47T10/40-2	6F	FL047	40	127,32	125,45	131,0	80	37	47	16	1,371
47T10/44-0	6	-	44	140,05	138,20	-	88	37	47	16	1,611
47T10/48-0	6	-	48	152,78	150,95	-	95	37	47	16	1,913
47T10/60-0	6	-	60	190,98	189,10	-	110	37	47	16	3,004

(Passo 10 mm)
per cinghia larghezza 50 mm

(Pitch 10 mm)
for belt width 50 mm

(Teilung 10 mm)
für Riemenbreite 50 mm

(Pas 10 mm)
pour courroies largeur 50 mm

(Paso 10 mm)
para correas ancho 50 mm

66T10/18-2	6F	FL021	18	57,29	55,45	60,0	40	56	66	10	0,422
66T10/19-2	6F	FL024	19	60,48	58,65	66,5	44	56	66	10	0,466
66T10/20-2	6F	FL024	20	63,66	61,80	66,5	46	56	66	12	0,520
66T10/22-2	6F	FL027	22	70,03	68,20	75,0	52	56	66	12	0,640
66T10/24-2	6F	FL029	24	76,39	74,55	83,0	58	56	66	12	0,736
66T10/25-2	6F	FL029	25	79,58	77,70	83,0	60	56	66	12	0,766
66T10/26-2	6F	FL031	26	82,76	80,90	87,0	60	56	66	12	0,845
66T10/27-2	6F	FL032	27	85,95	84,10	91,0	60	56	66	12	0,946
66T10/28-2	6F	FL033	28	89,12	87,25	93,0	60	56	66	12	0,110
66T10/30-2	6F	FL035	30	95,49	93,65	97,0	60	56	66	12	1,169
66T10/32-2	6F	FL038	32	101,86	100,00	106,0	65	56	66	12	1,300
66T10/36-2	6F	FL043	36	114,59	112,75	119,0	70	56	66	16	1,637
66T10/40-2	6F	FL047	40	127,32	125,45	131,0	80	56	66	16	1,999
66T10/44-0	6	-	44	140,05	138,20	-	88	56	66	16	2,420
66T10/48-0	6	-	48	152,78	150,95	-	95	56	66	16	2,830
66T10/60-0	6	-	60	190,98	189,10	-	110	56	66	16	4,366

PULEGGE DENTATE PER CINGHIE PASSO METRICO

TIMING BELT PULLEYS METRIC PITCH

Materiale:
Ghisa

Material:
Cast iron

Werkstoff:
Grauguss

Matière:
Fonte

Material:
Hierro fundido

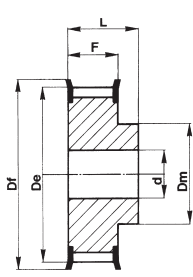

Tipo / Type
6F

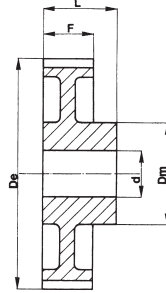

Tipo / Type
6W

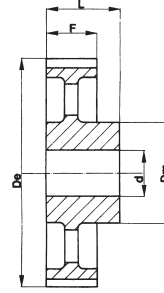

Tipo / Type
6A

T 20

(Passo 20 mm)
per cinghia larghezza 32 mm

(Pitch 20 mm)
for belt width 32 mm

(Teilung 20 mm)
für Riemenbreite 32 mm

(Pas 20 mm)
pour courroies largeur 32 mm

(Paso 20 mm)
para correas ancho 32 mm

Descrizione / Description Beschreibung / Description Descripción	Tipo Type / Typ Type / Tipo	Codice flangia Flange code / Bordscheiben Typ Code flasque / Código brida	N. denti N. of teeth / Zähnezahl N. bre de dents Cantidad de dientes	De	Df	Dm	F	L	d	Peso / Weight Gewicht / Poids / Peso Kg
53T20/18-2	6F	FL075	18	111,75	120,0	80	38	53	15	
53T20/20-2	6F	FL080	20	124,50	135,0	90	38	53	15	
53T20/22-2	6F	FL085	22	137,20	150,0	90	38	53	15	
53T20/24-2	6F	FL086	24	149,95	158,0	95	38	53	15	
53T20/25-2	6F	FL090	25	156,30	168,0	95	38	53	15	
53T20/30-2	6F	FL100	30	188,15	200,0	110	38	53	15	
53T20/32-2	6W	-	32	200,85	-	110	38	53	18	
53T20/36-2	6W	-	36	226,35	-	110	38	53	18	
53T20/40-2	6A	-	40	251,80	-	110	38	53	20	
53T20/48-2	6A	-	48	302,70	-	130	38	53	20	
53T20/60-2	6A	-	60	379,10	-	130	38	53	20	
53T20/72-2	6A	-	72	455,50	-	140	38	53	20	

(Passo 20 mm)
per cinghia larghezza 50 mm

(Pitch 20 mm)
for belt width 50 mm

(Teilung 20 mm)
für Riemenbreite 50 mm

(Pas 20 mm)
pour courroies largeur 50 mm

(Paso 20 mm)
para correas ancho 50 mm

71T20/18-2	6F	FL075	18	111,75	120,0	80	56	71	18	
71T20/20-2	6F	FL080	20	124,50	135,0	90	56	71	18	
71T20/22-2	6F	FL085	22	137,20	150,0	90	56	71	18	
71T20/24-2	6F	FL086	24	149,95	158,0	95	56	71	18	
71T20/25-2	6F	FL090	25	156,30	168,0	95	56	71	18	
71T20/30-2	6F	FL100	30	188,15	200,0	110	56	71	18	
71T20/32-2	6W	-	32	200,85	-	110	56	71	20	
71T20/36-2	6W	-	36	226,35	-	110	56	71	20	
71T20/40-2	6A	-	40	251,80	-	110	56	71	20	
71T20/48-2	6A	-	48	302,70	-	130	56	71	24	
71T20/60-2	6A	-	60	379,10	-	130	56	71	24	
71T20/72-2	6A	-	72	455,50	-	140	56	71	24	

(Passo 20 mm)
per cinghia larghezza 100 mm

(Pitch 20 mm)
for belt width 100 mm

(Teilung 20 mm)
für Riemenbreite 100 mm

(Pas 20 mm)
pour courroies largeur 100 mm

(Paso 20 mm)
para correas ancho 100 mm

123T20/18-2	6F	FL075	18	111,75	120,0	80	108	123	24	
123T20/20-2	6F	FL080	20	124,50	135,0	90	108	123	24	
123T20/22-2	6F	FL085	22	137,20	150,0	90	108	123	24	
123T20/24-2	6F	FL086	24	149,95	158,0	95	108	123	24	
123T20/25-2	6F	FL090	25	156,30	168,0	95	108	123	24	
123T20/30-2	6F	FL100	30	188,15	200,0	110	108	123	24	
123T20/32-2	6W	-	32	200,85	-	110	108	123	32	
123T20/36-2	6W	-	36	226,35	-	110	108	123	32	
123T20/40-2	6A	-	40	251,80	-	110	108	123	32	
123T20/48-2	6A	-	48	302,70	-	130	108	123	32	
123T20/60-2	6A	-	60	379,10	-	130	108	123	32	
123T20/72-2	6A	-	72	455,50	-	140	108	123	32	

BARRE DENTATE STANDARD STANDARD TOOTHED BARS

Materiale:
alluminio 6082 T6
UNI 9006/4 adatto al
trattamento anodico

Material:
aluminium 6082 T6
UNI 9006/4 suitable for
anodic treatment

Werkstoff:
Aluminium 6082 T6
UNI 9006/4 geeignet für
anodischen oxydation

Matière:
aluminium 6082 T6
UNI 9006/4 apte au
traitement anodique

Material:
aluminio 6082 T6
UNI 9006/4 apto para la
oxidacion anodica

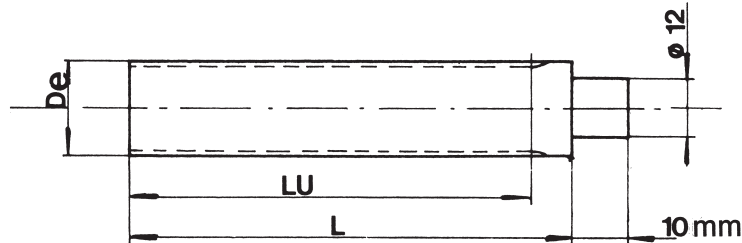

T 2,5

(Passo 2,5 mm) / (Pitch 2,5 mm) / (Teilung 2,5 mm)
(Pas 2,5 mm) / (Paso 2,5 mm)

Descrizione Description Beschreibung Description Descripción	N. denti N. of teeth / Zähnezahl N. bre de dents Cantidad de dientes	De	Lu	L
T2,5-10	10	7,42	50	75
T2,5-12	12	9,00	50	75
T2,5-13	13	9,80	50	75
T2,5-14	14	10,60	50	75
T2,5-15	15	11,40	50	75
T2,5-16	16	12,20	50	75
T2,5-17	17	13,00	50	75
T2,5-18	18	13,80	50	75
T2,5-19	19	14,60	90	120
T2,5-20	20	15,40	90	120
T2,5-21	21	16,20	90	120
T2,5-22	22	17,00	125	140
T2,5-24	24	18,55	125	140
T2,5-26	26	20,15	125	140
T2,5-27	27	20,95	125	140
T2,5-28	28	21,75	125	140
T2,5-29	29	22,55	125	140
T2,5-30	30	23,35	125	140
T2,5-32	32	24,95	125	140
T2,5-34	34	26,55	125	140
T2,5-35	35	27,35	132	140
T2,5-36	36	28,10	132	140
T2,5-38	38	29,70	132	140
T2,5-40	40	31,30	132	140
T2,5-42	42	32,90	140	140
T2,5-44	44	34,50	140	140
T2,5-45	45	35,30	140	140
T2,5-48	48	37,70	140	140
T2,5-50	50	39,29	160	160
T2,5-60	60	47,25	160	160
T2,5-65	65	51,20	160	160
T2,5-70	70	55,20	160	160
T2,5-72	72	56,80	160	160
T2,5-90	90	71,12	160	160
T2,5-100	100	79,08	160	160

T 5

(Passo 5 mm) / (Pitch 5 mm) / (Teilung 5 mm)
(Pas 5 mm) / (Paso 5 mm)

Descrizione Description Beschreibung Description Descripción	N. denti N. of teeth / Zähnezahl N. bre de dents Cantidad de dientes	De	Lu	L
T5-10	10	15,05	125	140
T5-11	11	16,65	125	140
T5-12	12	18,25	125	140
T5-13	13	19,85	125	140
T5-14	14	21,45	132	140
T5-15	15	23,05	132	140
T5-16	16	24,60	140	140
T5-17	17	26,20	140	140
T5-18	18	27,80	140	140
T5-19	19	29,40	140	140
T5-20	20	31,00	160	160
T5-21	21	32,70	160	160
T5-22	22	34,15	160	160
T5-23	23	35,85	160	160
T5-24	24	37,40	160	160
T5-25	25	38,95	160	160
T5-26	26	40,60	160	160
T5-27	27	42,20	160	160
T5-28	28	43,75	160	160
T5-29	29	45,35	160	160
T5-30	30	46,95	160	160
T5-32	32	50,10	160	160
T5-34	34	53,25	160	160
T5-35	35	54,85	160	160
T5-36	36	56,45	160	160
T5-37	37	58,06	160	160
T5-38	38	59,65	160	160
T5-40	40	62,85	160	160
T5-42	42	66,00	160	160
T5-44	44	69,20	160	160
T5-45	45	70,80	160	160
T5-46	46	72,40	160	160
T5-48	48	75,55	160	160
T5-50	50	78,75	160	160
T5-60	60	94,65	160	160
T5-72	72	113,75	160	160
T5-80	80	126,48	160	160
T5-90	90	142,40	160	160
T5-100	100	158,31	160	160

T 10

(Passo 10 mm) / (Pitch 10 mm) / (Teilung 10 mm)
(Pas 10 mm) / (Paso 10 mm)

Codice Code symbol Bezeichnung Code symbole Numero de fabrica	N. denti N. of teeth / Zähnezahl N. bre de dents Cantidad de dientes	De	Lu	L
T10-10	10	29,98	140	140
T10-11	11	33,16	140	140
T10-12	12	36,35	140	140
T10-13	13	39,50	140	140
T10-14	14	42,70	160	160
T10-15	15	45,90	160	160
T10-16	16	49,10	160	160
T10-17	17	52,25	160	160
T10-18	18	55,45	160	160
T10-19	19	58,65	160	160
T10-20	20	61,80	160	160
T10-21	21	65,00	160	160
T10-22	22	68,20	160	160
T10-23	23	71,35	160	160
T10-24	24	74,55	160	160
T10-26	26	80,90	160	160
T10-28	28	87,25	160	160
T10-30	30	93,65	160	160
T10-32	32	100,00	160	160
T10-34	34	106,40	160	160
T10-36	36	112,75	160	160
T10-38	38	119,10	160	160
T10-40	40	125,45	160	160
T10-45	45	141,40	160	160
T10-48	48	150,95	160	160
T10-60	60	189,10	160	160
T10-72	72	227,29	160	160

Per barre con n. di denti non
inclusi in queste tavole, chiedere
per quotazione.

For bars with a number of teeth
not included in these tables
please ask for our quotation.

Verlangen sie Angebot für
Stangen mit anzahl von Zaehnen
die nicht in diesen Tafeln
aufgefuehrt sind.

Pour les barreaux avec un
nombre de dents different du
tableau, nous consulter.

Pidan oferta por lo que
conciene una cantidad de
dientes no incluida en estas
tablas.

**PULEGGE PER CINGHIE DENTATE
PASSO METRICO ST PER CINGHIE «AT»
ST TIMING BELT PULLEYS METRIC PITCH FOR «AT» BELTS**



PULEGGE PER CINGHIE DENTATE PASSO METRICO ST PER CINGHIE «AT» ST TIMING BELT PULLEYS METRIC PITCH FOR «AT» BELTS

Materiale:
alluminio 6082 T6
UNI 9006/4 adatto al
trattamento anodico

Material:
aluminium 6082 T6
UNI 9006/4 suitable for
anodic treatment

Werkstoff:
Aluminium 6082 T6
UNI 9006/4 geeignet für
anodischen oxydation

Matière:
aluminium 6082 T6
UNI 9006/4 apte au
traitement anodique

Material:
aluminio 6082 T6
UNI 9006/4 apto para la
oxidacion anodica

Tipo / Type
6F

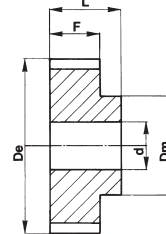
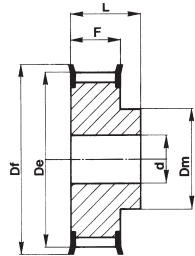

Tipo / Type
6

ST 5

(Passo 5 mm) per cinghia larghezza 10 mm (Pitch 5 mm) for belt width 10 mm (Teilung 5 mm) für Riemenbreite 10 mm (Pas 5 mm) pour courroies largeur 10 mm (Paso 5 mm) para correas ancho 10 mm

Descrizione / Description / Descripción	Tipo / Type / Typ	Codice flangia / Flange code / Bordscheiben Typ / Code flasque / Código brida	N. denti / N. of teeth / Zähnezahl / N. bre de dents / Cantidad de dientes	Dp	De	Df	Dm	F	L	d	Peso / Weight / Gewicht / Poids / Peso / Kg
21 ST5/12-2	6F	FL001	12	19,10	17,85	23,0	11	15	21	4	0,018
21 ST5/14-2	6F	FL002	14	22,29	21,05	25,0	13	15	21	4	0,019
21 ST5/15-2	6F	FL004	15	23,88	22,65	28,0	16	15	21	6	0,021
21 ST5/16-2	6F	FL005	16	25,47	24,20	32,0	18	15	21	6	0,025
21 ST5/18-2	6F	FL006	18	28,65	27,40	32,0	20	15	21	6	0,031
21 ST5/19-2	6F	FL008	19	30,25	29,00	36,0	22	15	21	6	0,036
21 ST5/20-2	6F	FL008	20	31,83	30,60	36,0	23	15	21	6	0,038
21 ST5/22-2	6F	FL009	22	35,02	33,85	38,0	24	15	21	6	0,048
21 ST5/24-2	6F	FL013	24	38,21	37,00	42,0	26	15	21	6	0,054
21 ST5/25-2	6F	FL012	25	39,80	38,60	44,0	26	15	21	6	0,058
21 ST5/26-2	6F	FL012	26	41,39	40,20	44,0	26	15	21	6	0,062
21 ST5/27-2	6F	FL011	27	42,98	41,80	48,0	30	15	21	8	0,064
21 ST5/28-2	6F	FL011	28	44,58	43,35	48,0	32	15	21	8	0,071
21 ST5/30-2	6F	FL016	30	47,76	46,55	51,0	34	15	21	8	0,076
21 ST5/32-2	6F	FL018	32	50,94	49,70	54,0	36	15	21	8	0,088
21 ST5/36-2	6F	FL023	36	57,31	56,05	64,0	38	15	21	8	0,114
21 ST5/40-2	6F	FL024	40	63,66	62,45	66,5	40	15	21	8	0,138
21 ST5/42-2	6F	FL026	42	66,86	65,60	70,0	40	15	21	8	0,180
21 ST5/44-0	6	-	44	70,05	68,80	-	45	15	21	8	0,185
21 ST5/48-0	6	-	48	76,42	75,15	-	50	15	21	8	0,200
21 ST5/60-0	6	-	60	95,52	94,25	-	65	15	21	8	0,307

(Passo 5 mm) per cinghia larghezza 16 mm (Pitch 5 mm) for belt width 16 mm (Teilung 5 mm) für Riemenbreite 16 mm (Pas 5 mm) pour courroies largeur 16 (Paso 5 mm) para correas ancho 16 mm

27 ST5/12-2	6F	FL001	12	19,10	17,85	23,0	11	21	27	4	0,022
27 ST5/14-2	6F	FL002	14	22,29	21,05	25,0	13	21	27	4	0,026
27 ST5/15-2	6F	FL004	15	23,88	22,65	28,0	16	21	27	6	0,029
27 ST5/16-2	6F	FL005	16	25,47	24,20	32,0	18	21	27	6	0,035
27 ST5/18-2	6F	FL006	18	28,65	27,40	32,0	20	21	27	6	0,043
27 ST5/19-2	6F	FL008	19	30,25	29,00	36,0	22	21	27	6	0,049
27 ST5/20-2	6F	FL008	20	31,83	30,60	36,0	23	21	27	6	0,053
27 ST5/22-2	6F	FL009	22	35,02	33,85	38,0	24	21	27	6	0,054
27 ST5/24-2	6F	FL013	24	38,21	37,00	42,0	26	21	27	6	0,076
27 ST5/25-2	6F	FL012	25	39,80	38,60	44,0	26	21	27	6	0,081
27 ST5/26-2	6F	FL012	26	41,39	40,20	44,0	26	21	27	6	0,085
27 ST5/27-2	6F	FL011	27	42,98	41,80	48,0	30	21	27	8	0,090
27 ST5/28-2	6F	FL011	28	44,58	43,35	48,0	32	21	27	8	0,092
27 ST5/30-2	6F	FL016	30	47,76	46,55	51,0	34	21	27	8	0,105
27 ST5/32-2	6F	FL018	32	50,94	49,70	54,0	36	21	27	8	0,123
27 ST5/36-2	6F	FL023	36	57,31	56,05	64,0	38	21	27	8	0,160
27 ST5/40-2	6F	FL024	40	63,66	62,45	66,5	40	21	27	8	0,193
27 ST5/42-2	6F	FL026	42	66,86	65,60	70,0	40	21	27	8	0,205
27 ST5/44-0	6	-	44	70,05	68,80	-	45	21	27	8	0,228
27 ST5/48-0	6	-	48	76,42	75,15	-	50	21	27	8	0,280
27 ST5/60-0	6	-	60	95,52	94,25	-	65	21	27	8	0,430

(Passo 5 mm) per cinghia larghezza 25 mm (Pitch 5 mm) for belt width 25 mm (Teilung 5 mm) für Riemenbreite 25 mm (Pas 5 mm) pour courroies largeur 25 mm (Paso 5 mm) para correas ancho 25 mm

36 ST5/12-2	6F	FL001	12	19,10	17,85	23,0	11	30	36	4	0,031
36 ST5/14-2	6F	FL002	14	22,29	21,05	25,0	13	30	36	4	0,037
36 ST5/15-2	6F	FL004	15	23,88	22,65	28,0	16	30	36	6	0,041
36 ST5/16-2	6F	FL005	16	25,47	24,20	32,0	18	30	36	6	0,050
36 ST5/18-2	6F	FL006	18	28,65	27,40	32,0	20	30	36	6	0,061
36 ST5/19-2	6F	FL008	19	30,25	29,00	36,0	22	30	36	6	0,070
36 ST5/20-2	6F	FL008	20	31,83	30,60	36,0	23	30	36	6	0,076
36 ST5/22-2	6F	FL009	22	35,02	33,85	38,0	24	30	36	6	0,080
36 ST5/24-2	6F	FL013	24	38,21	37,00	42,0	26	30	36	6	0,109
36 ST5/25-2	6F	FL012	25	39,80	38,60	44,0	26	30	36	6	0,118
36 ST5/26-2	6F	FL012	26	41,39	40,20	44,0	26	30	36	6	0,120
36 ST5/27-2	6F	FL011	27	42,98	41,80	48,0	30	30	36	8	0,128
36 ST5/28-2	6F	FL011	28	44,58	43,35	48,0	32	30	36	8	0,135
36 ST5/30-2	6F	FL016	30	47,76	46,55	51,0	34	30	36	8	0,150
36 ST5/32-2	6F	FL018	32	50,94	49,70	54,0	36	30	36	8	0,178
36 ST5/36-2	6F	FL023	36	57,31	56,05	64,0	38	30	36	8	0,230
36 ST5/40-2	6F	FL024	40	63,66	62,45	66,5	40	30	36	8	0,278
36 ST5/42-2	6F	FL026	42	66,86	65,60	70,0	40	30	36	8	0,284
36 ST5/44-0	6	-	44	70,05	68,80	-	45	30	36	8	0,315
36 ST5/48-0	6	-	48	76,42	75,15	-	50	30	36	8	0,400
36 ST5/60-0	6	-	60	95,52	94,25	-	65	30	36	8	0,614

PULEGGE PER CINGHIE DENTATE PASSO METRICO ST PER CINGHIE «AT» ST TIMING BELT PULLEYS METRIC PITCH FOR «AT» BELTS

Materiale:
alluminio 6082 T6
UNI 9006/4 adatto al
trattamento anodico

Material:
aluminium 6082 T6
UNI 9006/4 suitable for
anodic treatment

Werkstoff:
Aluminium 6082 T6
UNI 9006/4 geeignet für
anodischen oxydation

Matière:
aluminium 6082 T6
UNI 9006/4 apte au
traitement anodique

Material:
aluminio 6082 T6
UNI 9006/4 apto para la
oxidacion anodica

Tipo / Type
6F

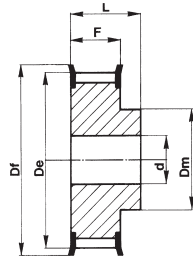

Tipo / Type
6

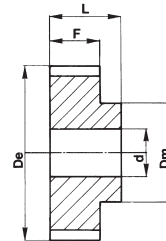

ST 10

(Passo 10 mm)
per cinghia larghezza 16 mm

(Pitch 10 mm)
for belt width 16 mm

(Teilung 10 mm)
für Riemenbreite 16 mm

(Pas 10 mm)
pour courroies largeur 16 mm

(Paso 10 mm)
para correas ancho 16 mm

Descrizione / Description / Descripción	Tipo / Typ / Type / Tipo	Codice flangia / Flange code / Bordscheiben Typ / Code flasque / Código brida	N. denti / N. of teeth / Zähnezahl / N. bre de dents / Cantidad de dientes	Dp	De	Df	Dm	F	L	d	Peso / Weight / Gewicht / Poids / Peso / Kg
31 ST10/15-2	6F	FL016	15	47,75	45,90	51,0	31	21	31	8	0,118
31 ST10/16-2	6F	FL018	16	50,93	49,05	54,0	35	21	31	8	0,134
31 ST10/18-2	6F	FL021	18	57,29	55,45	60,0	40	21	31	8	0,167
31 ST10/19-2	6F	FL024	19	60,48	58,60	66,5	44	21	31	8	0,184
31 ST10/20-2	6F	FL024	20	63,66	61,80	66,5	46	21	31	8	0,208
31 ST10/22-2	6F	FL027	22	70,03	68,15	75,0	52	21	31	8	0,253
31 ST10/24-2	6F	FL029	24	76,39	74,55	83,0	58	21	31	8	0,288
31 ST10/25-2	6F	FL029	25	79,58	77,70	83,0	60	21	31	8	0,310
31 ST10/26-2	6F	FL031	26	82,76	80,90	87,0	60	21	31	8	0,357
31 ST10/27-2	6F	FL032	27	85,95	84,10	91,0	60	21	31	8	0,364
31 ST10/28-2	6F	FL033	28	89,12	87,25	93,0	60	21	31	8	0,401
31 ST10/30-2	6F	FL035	30	95,49	93,65	97,0	60	21	31	8	0,441
31 ST10/32-2	6F	FL038	32	101,86	100,00	106,0	65	21	31	10	0,493
31 ST10/36-2	6F	FL043	36	114,59	112,75	119,0	70	21	31	10	0,623
31 ST10/40-2	6F	FL047	40	127,32	125,45	131,0	80	21	31	10	0,787
31 ST10/44-0	6	-	44	140,05	138,20	-	88	21	31	10	0,993
31 ST10/48-0	6	-	48	152,78	150,95	-	95	21	31	16	1,090
31 ST10/60-0	6	-	60	190,98	189,10	-	110	21	31	16	1,701

(Passo 10 mm)
per cinghia larghezza 25 mm

(Pitch 10 mm)
for belt width 25 mm

(Teilung 10 mm)
für Riemenbreite 25 mm

(Pas 10 mm)
pour courroies largeur 25 mm

(Paso 10 mm)
para correas ancho 25 mm

40 ST10/15-2	6F	FL016	15	47,75	45,90	51,0	31	30	40	8	0,152
40 ST10/16-2	6F	FL018	16	50,93	49,05	54,0	35	30	40	8	0,176
40 ST10/18-2	6F	FL021	18	57,29	55,45	60,0	40	30	40	8	0,224
40 ST10/19-2	6F	FL024	19	60,48	58,60	66,5	44	30	40	8	0,247
40 ST10/20-2	6F	FL024	20	63,66	61,80	66,5	46	30	40	8	0,276
40 ST10/22-2	6F	FL027	22	70,03	68,15	75,0	52	30	40	8	0,337
40 ST10/24-2	6F	FL029	24	76,39	74,55	83,0	58	30	40	8	0,392
40 ST10/25-2	6F	FL029	25	79,58	77,70	83,0	60	30	40	8	0,422
40 ST10/26-2	6F	FL031	26	82,76	80,90	87,0	60	30	40	8	0,477
40 ST10/27-2	6F	FL032	27	85,95	84,10	91,0	60	30	40	8	0,536
40 ST10/28-2	6F	FL033	28	89,12	87,25	93,0	60	30	40	8	0,540
40 ST10/30-2	6F	FL035	30	95,49	93,65	97,0	60	30	40	8	0,640
40 ST10/32-2	6F	FL038	32	101,86	100,00	106,0	65	30	40	10	0,693
40 ST10/36-2	6F	FL043	36	114,59	112,75	119,0	70	30	40	10	0,873
40 ST10/40-2	6F	FL047	40	127,32	125,45	131,0	80	30	40	10	1,067
40 ST10/44-0	6	-	44	140,05	138,20	-	88	30	40	10	1,350
40 ST10/48-0	6	-	48	152,78	150,95	-	95	30	40	16	1,516
40 ST10/60-0	6	-	60	190,98	189,10	-	110	30	40	16	2,339

PULEGGE PER CINGHIE DENTATE PASSO METRICO ST PER CINGHIE «AT» ST TIMING BELT PULLEYS METRIC PITCH FOR «AT» BELTS

Materiale:
alluminio 6082 T6
UNI 9006/4 adatto al
trattamento anodico

Material:
aluminium 6082 T6
UNI 9006/4 suitable for
anodic treatment

Werkstoff:
Aluminium 6082 T6
UNI 9006/4 geeignet für
anodischen oxydation

Matière:
aluminium 6082 T6
UNI 9006/4 apte au
traitement anodique

Material:
aluminio 6082 T6
UNI 9006/4 apto para la
oxidacion anodica

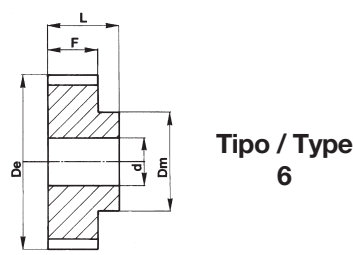
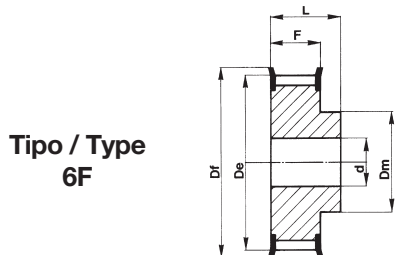

ST 10

(Passo 10 mm)
per cinghia larghezza 32 mm

(Pitch 10 mm)
for belt width 32 mm

(Teilung 10 mm)
für Riemenbreite 32 mm

(Pas 10 mm)
pour courroies largeur 32 mm

(Paso 10 mm)
para correas ancho 32 mm

Descrizione / Description Beschreibung / Description Descripción	Tipo Type / Typ Type / Tipo	Codice flangia Flange code / Bordscheiben Typ Code flasque / Código brida	N. denti N. of teeth / Zähnezahl N. bre de dents Cantidad de dientes	Dp	De	Df	Dm	F	L	d	Peso / Weight Gewicht / Poids / Peso Kg
47 ST10/18-2	6F	FL021	18	57,29	55,45	60,0	40	37	47	10	0,253
47 ST10/19-2	6F	FL024	19	60,48	58,60	66,5	44	37	47	10	0,286
47 ST10/20-2	6F	FL024	20	63,66	61,80	66,5	46	37	47	12	0,322
47 ST10/22-2	6F	FL027	22	70,03	68,15	75,0	52	37	47	12	0,393
47 ST10/24-2	6F	FL029	24	76,39	74,55	83,0	58	37	47	12	0,475
47 ST10/25-2	6F	FL029	25	79,58	77,70	83,0	60	37	47	12	0,527
47 ST10/26-2	6F	FL031	26	82,76	80,90	87,0	60	37	47	12	0,564
47 ST10/27-2	6F	FL032	27	85,95	84,10	91,0	60	37	47	12	0,602
47 ST10/28-2	6F	FL033	28	89,12	87,25	93,0	60	37	47	12	0,642
47 ST10/30-2	6F	FL035	30	95,49	93,65	97,0	60	37	47	12	0,740
47 ST10/32-2	6F	FL038	32	101,86	100,00	106,0	65	37	47	12	0,844
47 ST10/36-2	6F	FL043	36	114,59	112,75	119,0	70	37	47	16	1,063
47 ST10/40-2	6F	FL047	40	127,32	125,45	131,0	80	37	47	16	1,317
47 ST10/44-0	6	-	44	140,05	138,20	-	88	37	47	16	1,611
47 ST10/48-0	6	-	48	152,78	150,95	-	95	37	47	16	1,931
47 ST10/60-0	6	-	60	190,98	189,10	-	110	37	47	16	3,004

(Passo 10 mm)
per cinghia larghezza 50 mm

(Pitch 10 mm)
for belt width 50 mm

(Teilung 10 mm)
für Riemenbreite 50 mm

(Pas 10 mm)
pour courroies largeur 50 mm

(Paso 10 mm)
para correas ancho 50 mm

66 ST10/18-2	6F	FL021	18	57,29	55,45	60,0	40	56	66	10	0,422
66 ST10/19-2	6F	FL024	19	60,48	58,60	66,5	44	56	66	10	0,466
66 ST10/20-2	6F	FL024	20	63,66	61,80	66,5	46	56	66	12	0,520
66 ST10/22-2	6F	FL027	22	70,03	68,15	75,0	52	56	66	12	0,570
66 ST10/24-2	6F	FL029	24	76,39	74,55	83,0	58	56	66	12	0,736
66 ST10/25-2	6F	FL029	25	79,58	77,70	83,0	60	56	66	12	0,766
66 ST10/26-2	6F	FL031	26	82,76	80,90	87,0	60	56	66	12	0,816
66 ST10/27-2	6F	FL032	27	85,95	84,10	91,0	60	56	66	12	0,946
66 ST10/28-2	6F	FL033	28	89,12	87,25	93,0	60	56	66	12	0,960
66 ST10/30-2	6F	FL035	30	95,49	93,65	97,0	60	56	66	12	1,169
66 ST10/32-2	6F	FL038	32	101,86	100,00	106,0	65	56	66	12	1,300
66 ST10/36-2	6F	FL043	36	114,59	112,75	119,0	70	56	66	16	1,637
66 ST10/40-2	6F	FL047	40	127,32	125,45	131,0	80	56	66	16	1,999
66 ST10/44-0	6	-	44	140,05	138,20	-	88	56	66	16	2,357
66 ST10/48-0	6	-	48	152,78	150,95	-	95	56	66	16	2,830
66 ST10/60-0	6	-	60	190,98	189,10	-	110	56	66	16	4,368

BARRE DENTATE STANDARD ST PER CINGHIE " AT "

ST STANDARD TOOTHED BARS FOR " AT " BELTS

Materiale:
alluminio 6082 T6
UNI 9006/4 adatto al
trattamento anodico

Material:
aluminium 6082 T6
UNI 9006/4 suitable for
anodic treatment

Werkstoff:
aluminium 6082 T6
UNI 9006/4 geeignet für
anodischen oxydation

Matière:
aluminium 6082 T6
UNI 9006/4 apte au
traitement anodique

Material:
aluminio 6082 T6
UNI 9006/4 apto para la
oxidacion anodica

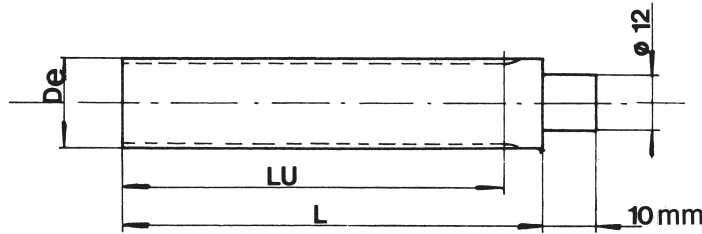

ST 5

(Passo 5 mm) / (Pitch 5 mm) / (Teilung 5 mm) / (Pas 5 mm) / (Paso 5 mm)

Descrizione Description Beschreibung Description Descripción	N. denti N. of teeth / Zähnezahl N. bre de dents Cantidad de dientes	De	Lu	L
ST05012	12	17,85	125	140
ST05013	13	19,45	125	140
ST05014	14	21,05	132	140
ST05015	15	22,65	132	140
ST05016	16	24,20	140	140
ST05017	17	25,80	140	140
ST05018	18	27,40	140	140
ST05019	19	29,00	140	140
ST05020	20	30,60	160	160
ST05021	21	32,30	160	160
ST05022	22	33,85	160	160
ST05023	23	35,45	160	160
ST05024	24	37,00	160	160
ST05025	25	38,60	160	160
ST05026	26	40,20	160	160
ST05027	27	41,80	160	160
ST05028	28	43,35	160	160
ST05029	29	44,95	160	160
ST05030	30	46,55	160	160
ST05031	31	48,15	160	160
ST05032	32	49,70	160	160
ST05033	33	51,30	160	160
ST05034	34	52,85	160	160
ST05035	35	54,45	160	160
ST05036	36	56,05	160	160
ST05038	38	59,25	160	160
ST05040	40	62,45	160	160
ST05042	42	65,60	160	160
ST05044	44	68,80	160	160
ST05045	45	70,40	160	160
ST05046	46	72,00	160	160
ST05048	48	75,15	160	160
ST05050	50	78,35	160	160
ST05052	52	81,55	160	160
ST05054	54	84,70	160	160
ST05055	55	86,30	160	160
ST05056	56	87,90	160	160
ST05058	58	91,10	160	160
ST05060	60	94,25	160	160
ST05062	62	97,45	160	160
ST05064	64	100,65	160	160
ST05065	65	102,25	160	160
ST05070	70	110,20	160	160
ST05072	72	113,25	160	160

ST 10

(Passo 10 mm) / (Pitch 10 mm) / (Teilung 10 mm) / (Pas 10 mm) / (Paso 10 mm)

Codice Code symbol Bezeichnung Code symbole Numero de fabrica	N. denti N. of teeth / Zähnezahl N. bre de dents Cantidad de dientes	De	Lu	L
ST10015	15	45,90	160	160
ST10016	16	49,05	160	160
ST10017	17	52,25	160	160
ST10018	18	55,45	160	160
ST10019	19	58,60	160	160
ST10020	20	61,80	160	160
ST10021	21	65,00	160	160
ST10022	22	68,15	160	160
ST10023	23	71,35	160	160
ST10024	24	74,55	160	160
ST10025	25	77,70	160	160
ST10026	26	80,90	160	160
ST10027	27	84,10	160	160
ST10028	28	87,25	160	160
ST10029	29	90,45	160	160
ST10030	30	93,65	160	160
ST10031	31	96,80	160	160
ST10032	32	100,00	160	160
ST10033	33	103,20	160	160
ST10034	34	106,40	160	160
ST10035	35	109,55	160	160
ST10036	36	112,75	160	160
ST10037	37	115,90	160	160
ST01038	38	119,10	160	160
ST10040	40	125,45	160	160
ST10041	41	128,65	160	160
ST10042	42	131,85	160	160
ST10044	44	138,20	160	160
ST10045	45	141,40	160	160
ST48046	46	144,55	160	160
ST10048	48	150,95	160	160
ST10050	50	157,30	160	160
ST10051	51	160,50	160	160
ST10052	52	163,65	160	160
ST10054	54	170,05	160	160
ST10055	55	173,20	160	160
ST10056	56	176,40	160	160
ST10057	57	179,60	160	160
ST10058	58	182,75	160	160
ST10059	59	185,95	160	160
ST10060	60	189,10	160	160
ST10062	62	195,50	160	160
ST10070	70	220,95	160	160
ST10075	75	236,90	160	160

**PULEGGE DENTATE PER CINGHIE CON PROFILO HTD
TIMING BELT PULLEYS HTD PROFILE**



PULEGGE DENTATE PER CINGHIE CON PROFILO HTD TIMING BELT PULLEYS HTD PROFILE

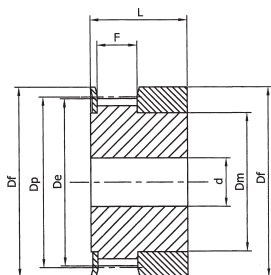

Tipo / Type
1F

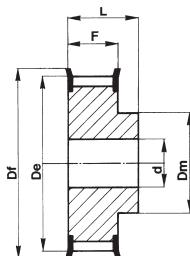

Tipo / Type
6F

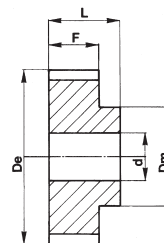

Tipo / Type
6

HTD Profile 3M-06

Caratteristiche Features Merkmale Características	Descrizione Description Beschreibung Description Descripción	Tipo Type Typ Type Tipo	Codice flangia Flange code Bordscheiben Typ Code flasque Código brida	N. denti N. of teeth / Zähnezahl N. bre de dents Cantidad de dientes	Dp	De	Df	Dm	F	L	Foro stock Stock bore Vor bohrung Alesage en stock Agujero de stock	Peso Weight / Gewicht Poids / Peso Kg
Alluminio / Aluminium / Aluminium / Aluminium / Aluminio 6082 T6 UNI 9006/4	con flangia / with flanges mit Flanges / avec flasques con tapetas	10 3M 06	1F	FL501	10	9,55	8,79	13,0	6,0	7,2	14,5	4
		12 3M 06	1F	FL502	12	11,46	10,70	15,0	8,0	7,2	14,5	4
		14 3M 06	1F	FL503	14	13,37	12,61	16,0	9,5	7,2	14,5	4
		153M 06	1F	FL516	15	14,32	13,56	17,5	10,5	7,2	14,5	4
		16 3M 06	6F	FL504	16	15,28	14,52	17,5	10,0	9,8	17,5	4
		18 3M 06	6F	FL505	18	17,19	16,43	20,0	11,0	9,8	17,5	6
		20 3M 06	6F	FL517	20	19,10	18,34	23,0	13,0	9,8	17,5	6
		21 3M 06	6F	FL518	21	20,05	19,29	25,0	13,0	9,8	17,5	6
		22 3M 06	6F	FL518	22	21,01	20,25	25,0	13,0	9,8	17,5	6
		24 3M 06	6F	FL518	24	22,92	22,16	25,0	13,0	9,8	17,5	6
		26 3M 06	6F	FL508	26	24,83	24,07	28,0	16,0	9,8	17,5	6
		28 3M 06	6F	FL509	28	26,74	25,98	32,0	18,0	9,8	17,5	6
		30 3M 06	6F	FL509	30	28,65	27,89	32,0	20,0	9,8	17,5	6
		32 3M 06	6F	FL510	32	30,56	29,80	36,0	22,0	9,8	17,5	6
		36 3M 06	6F	FL519	36	34,38	33,62	39,0	26,0	10,3	18,0	6
		40 3M 06	6F	FL513	40	38,20	37,44	42,0	28,0	10,3	18,0	6
44 3M 06	6F	FL520	44	42,02	41,26	48,0	33,0	10,3	18,0	6		
senza flangia / without flanges ohne Flanschen / sans flasques sin tapetas		48 3M 06	6	-	48	45,84	45,08	-	33,0	10,3	18,6	8
		60 3M 06	6	-	60	57,30	56,54	-	33,0	10,3	18,6	8
		72 3M 06	6	-	72	68,75	67,99	-	33,0	10,3	18,6	8

PULEGGE DENTATE PER CINGHIE CON PROFILO HTD TIMING BELT PULLEYS HTD PROFILE

HTD Profile 3M-09

Caratteristiche Features Merkmale Características Características	Descrizione Description Beschreibung Description Descripción	Tipo Type Typ Type Tipo	Codice flangia Flange code Bordscheiben Typ Code flasque Código brida	N. denti N. of teeth / Zahnzahl N. bre de dents Cantidad de dientes	Dp	De	Df	Dm	F	L	Foro stock Stock bore Vor bohrung Alesage en stock Agujero de stock	Peso Weight / Gewicht Poids / Peso Kg		
Alluminio / Aluminium / Aluminium / Aluminium / Aluminio 6082 T6 UNI 9006/4	con flangia / with flanges mit Flanges / avec flasques con tapetas	10 3M 09	FL501	10	9,55	8,79	13,0	6,0	10,2	17,5	4	0,004		
		12 3M 09	FL502	12	11,46	10,70	15,0	8,0	10,2	17,5	4	0,006		
		14 3M 09	FL503	14	13,37	12,61	16,0	9,5	10,2	17,5	4	0,007		
		15 3M 09	FL516	15	14,32	13,56	17,5	10,5	10,2	17,5	4	0,008		
		16 3M 09	FL504	16	15,28	14,52	17,5	10,0	12,8	20,6	4	0,007		
		18 3M 09	FL505	18	17,19	16,43	20,0	10,6	12,8	20,6	6	0,008		
		20 3M 09	FL517	20	19,10	18,34	23,0	12,4	12,8	20,6	6	0,010		
		21 3M 09	FL518	21	20,05	19,29	25,0	13,0	12,8	20,6	6	0,013		
		22 3M 09	FL518	22	21,01	20,25	25,0	13,0	12,8	20,6	6	0,014		
		24 3M 09	FL518	24	22,92	22,16	25,0	13,0	12,8	20,6	6	0,016		
		26 3M 09	FL508	26	24,83	24,07	28,0	16,0	12,8	20,6	6	0,018		
		28 3M 09	FL509	28	26,74	25,98	32,0	18,0	12,8	20,6	6	0,024		
		30 3M 09	FL509	30	28,65	27,89	32,0	20,0	12,8	20,6	6	0,028		
		32 3M 09	FL510	32	30,56	29,80	36,0	22,0	12,8	20,6	6	0,032		
		36 3M 09	FL519	36	34,38	33,62	39,0	26,0	13,4	22,2	6	0,045		
		40 3M 09	FL513	40	38,20	37,44	42,0	28,0	13,4	22,2	6	0,055		
		44 3M 09	FL520	44	42,02	41,26	48,0	33,0	13,4	22,2	6	0,074		
		senza flangia / without flanges / ohne Flanschen sans flasques / sin tapetas												
			48 3M 09	6		48	45,84	45,08	-	33,0	13,4	22,2	8	0,074
			60 3M 09	6		60	57,30	56,54	-	33,0	13,4	22,2	8	0,106
	72 3M 09	6		72	68,75	67,99	-	33,0	13,4	22,2	8	0,145		

HTD Profile 3M-15

Caratteristiche Features Merkmale Características Características	Descrizione Description Beschreibung Description Descripción	Tipo Type Typ Type Tipo	Codice flangia Flange code Bordscheiben Typ Code flasque Código brida	N. denti N. of teeth / Zahnzahl N. bre de dents Cantidad de dientes	Dp	De	Df	Dm	F	L	Foro stock Stock bore Vor bohrung Alesage en stock Agujero de stock	Peso Weight / Gewicht Poids / Peso Kg		
Alluminio / Aluminium / Aluminium / Aluminium / Aluminio 6082 T6 UNI 9006/4	con flangia / with flanges mit Flanges / avec flasques con tapetas	10 3M 15	FL501	10	9,55	8,79	13,0	6,0	17,0	26,0	4	0,006		
		12 3M 15	FL502	12	11,46	10,70	15,0	8,0	17,0	26,0	4	0,008		
		14 3M 15	FL503	14	13,37	12,61	16,0	9,5	17,0	26,0	4	0,010		
		15 3M 15	FL516	15	14,32	13,56	17,5	10,5	17,0	26,0	4	0,012		
		16 3M 15	FL504	16	15,28	14,52	17,5	10,0	19,5	26,0	4	0,010		
		18 3M 15	FL505	18	17,19	16,43	20,0	10,6	19,5	26,0	6	0,012		
		20 3M 15	FL517	20	19,10	18,34	23,0	12,4	19,5	26,0	6	0,014		
		21 3M 15	FL518	21	20,05	19,29	25,0	13,0	19,5	26,0	6	0,016		
		22 3M 15	FL518	22	21,01	20,25	25,0	13,0	19,5	26,0	6	0,018		
		24 3M 15	FL518	24	22,92	22,16	25,0	13,0	19,5	26,0	6	0,020		
		26 3M 15	FL508	26	24,83	24,07	28,0	16,0	19,5	26,0	6	0,027		
		28 3M 15	FL509	28	26,74	25,98	32,0	18,0	19,5	26,0	6	0,030		
		30 3M 15	FL509	30	28,65	27,89	32,0	20,0	19,5	26,0	6	0,035		
		32 3M 15	FL510	32	30,56	29,80	36,0	22,0	19,5	26,0	6	0,042		
		36 3M 15	FL519	36	34,38	33,62	39,0	26,0	20,0	30,0	6	0,060		
		40 3M 15	FL513	40	38,20	37,44	42,0	28,0	20,0	30,0	6	0,075		
		44 3M 15	FL520	44	42,02	41,26	48,0	33,0	20,0	30,0	6	0,095		
		senza flangia / without flanges / ohne Flanschen sans flasques / sin tapetas												
			48 3M 15	6	-	48	45,84	45,08	-	33,0	20,0	30,0	8	0,103
			60 3M 15	6	-	60	57,30	56,54	-	33,0	20,0	30,0	8	0,150
	72 3M 15	6	-	72	68,75	67,99	-	33,0	20,0	30,0	8	0,212		

PULEGGE DENTATE PER CINGHIE CON PROFILO HTD TIMING BELT PULLEYS HTD PROFILE

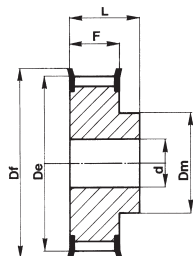

Tipo / Type
6F

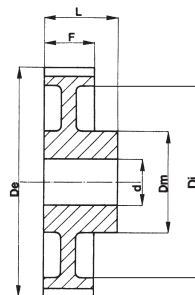

Tipo / Type
6W

HTD Profile 5M-09

Caratteristiche Features Merkmale Características	Descrizione Description Beschreibung Description Descripción	Tipo Type Typ Type Tipo	Codice flangia Flange code Bordscheiben Typ Code flasque Código brida	N. denti N. of teeth / Zähnezahl N. bre de dents Cantidad de dientes	Dp	De	Df	Dm	Di	F	L	Foro stock Stock bore Vor bohrung Alesage en stock Agujero de stock	Peso Weight / Gewicht Poids / Peso Kg	
Acciaio / Steel / Stahl Acier / Acero	con flangia / with flanges mit Flanges / avec flasques con tapetas	12 5M 09	6F	FL014	12	19,10	17,96	23,0	12,0	-	14,5	20,0	4	0,028
		14 5M 09	6F	FL002	14	22,28	21,14	25,0	13,0	-	14,5	20,0	6	0,034
		15 5M 09	6F	FL004	15	23,87	22,73	28,0	16,0	-	14,5	20,0	6	0,042
		16 5M 09	6F	FL004	16	25,46	24,32	28,0	16,5	-	14,5	20,0	6	0,050
		18 5M 09	6F	FL006	18	28,65	27,51	32,0	20,0	-	14,5	20,0	6	0,070
		20 5M 09	6F	FL008	20	31,83	30,69	36,0	23,0	-	14,5	22,5	6	0,094
		21 5M 09	6F	FL009	21	33,42	32,28	38,0	24,0	-	14,5	22,5	6	0,110
		22 5M 09	6F	FL015	22	35,01	33,87	39,0	25,5	-	14,5	22,5	6	0,118
		24 5M 09	6F	FL013	24	38,20	37,06	42,0	27,0	-	14,5	22,5	6	0,145
		26 5M 09	6F	FL012	26	41,38	40,24	44,0	30,0	-	14,5	22,5	6	0,170
		28 5M 09	6F	FL011	28	44,56	43,42	48,0	30,5	-	14,5	22,5	6	0,200
		30 5M 09	6F	FL016	30	47,75	46,60	51,0	35,0	-	14,5	22,5	6	0,236
		32 5M 09	6F	FL018	32	50,93	49,79	54,0	38,0	-	14,5	22,5	8	0,210
		36 5M 09	6F	FL021	36	57,30	56,16	60,0	38,0	-	14,5	22,5	8	0,324
40 5M 09	6F	FL025	40	63,66	62,52	71,0	38,0	-	14,5	22,5	8	0,400		
Alluminio / Aluminium Aluminium / Aluminium Aluminio	senza flangia / without flanges / ohne Flanschen sans flasques / sin tapetas	44 5M 09	6W	-	44	70,03	68,89	-	38,0	54	14,5	25,5	8	0,170
		48 5M 09	6W	-	48	76,39	75,25	-	45,0	61	14,5	25,5	8	0,182
		60 5M 09	6W	-	60	95,46	94,35	-	45,0	80	14,5	25,5	8	0,230
		72 5M 09	6W	-	72	114,59	113,45	-	45,0	100	14,5	25,5	8	0,270

PULEGGE DENTATE PER CINGHIE CON PROFILO HTD TIMING BELT PULLEYS HTD PROFILE

HTD Profile 5M-15

Caratteristiche Features Merkmale Características Características	Descrizione Description Beschreibung Description Descripción	Tipo Type Typ Type Tipo	Codice flangia Flange code Bordscheiben Typ Code flasque Código brida	N. denti N. of teeth / Zähnezahl N. bre de dents Cantidad de dientes	Dp	De	Df	Dm	Di	F	L	Foro stock Stock bore Vor bohrung Alesage en stock Agujero de stock	Peso Weight / Gewicht Poids / Peso Kg	
Acciaio / Steel / Stahl Acier / Acero	con flangia / with flanges mit Flanges / avec flasques con tapetas	12 5M 15	6F	FL014	12	19,10	17,96	23,0	12,0	-	20,5	26,0	4	0,034
		14 5M 15	6F	FL002	14	22,28	21,14	25,0	13,0	-	20,5	26,0	6	0,046
		15 5M 15	6F	FL004	15	23,87	22,73	28,0	16,0	-	20,5	26,0	6	0,056
		16 5M 15	6F	FL004	16	25,46	24,32	28,0	16,5	-	20,5	26,0	6	0,064
		18 5M 15	6F	FL006	18	28,65	27,51	32,0	20,0	-	20,5	26,0	6	0,086
		20 5M 15	6F	FL008	20	31,83	30,69	36,0	23,0	-	20,5	26,0	6	0,112
		21 5M 15	6F	FL009	21	33,42	32,28	38,0	24,0	-	20,5	26,0	6	0,130
		22 5M 15	6F	FL015	22	35,01	33,87	39,0	25,5	-	20,5	26,0	6	0,140
		24 5M 15	6F	FL013	24	38,20	37,06	42,0	27,0	-	20,5	28,0	6	0,180
		26 5M 15	6F	FL012	26	41,38	40,24	44,0	30,0	-	20,5	28,0	6	0,220
		28 5M 15	6F	FL011	28	44,56	43,42	48,0	30,5	-	20,5	28,0	6	0,250
		30 5M 15	6F	FL016	30	47,75	46,60	51,0	35,0	-	20,5	28,0	6	0,300
		32 5M 15	6F	FL018	32	50,93	49,79	54,0	38,0	-	20,5	28,0	8	0,350
		36 5M 15	6F	FL021	36	57,30	56,16	60,0	38,0	-	20,5	28,0	8	0,426
40 5M 15	6F	FL025	40	63,66	62,52	71,0	38,0	-	20,5	28,0	8	0,520		
Alluminio / Aluminium Aluminium / Aluminium Aluminio	senza flangia / without flanges / ohne Flanschen sans flasques / sin tapetas	44 5M 15	6W	-	44	70,03	68,89	-	38,0	54	20,5	30,0	8	0,225
		48 5M 15	6W	-	48	76,39	75,25	-	45,0	61	20,5	30,0	8	0,187
		60 5M 15	6W	-	60	95,46	94,35	-	45,0	80	20,5	30,0	8	0,305
		72 5M 15	6W	-	72	114,59	113,45	-	45,0	100	20,5	30,0	8	0,305

HTD Profile 5M-25

Caratteristiche Features Merkmale Características Características	Descrizione Description Beschreibung Description Descripción	Tipo Type Typ Type Tipo	Codice flangia Flange code Bordscheiben Typ Code flasque Código brida	N. denti N. of teeth / Zähnezahl N. bre de dents Cantidad de dientes	Dp	De	Df	Dm	Di	F	L	Foro stock Stock bore Vor bohrung Alesage en stock Agujero de stock	Peso Weight / Gewicht Poids / Peso Kg	
Acciaio / Steel / Stahl Acier / Acero	con flangia / with flanges mit Flanges / avec flasques con tapetas	12 5M 25	6F	FL014	12	19,10	17,96	23,0	12,0	-	30,5	36,0	4	0,050
		14 5M 25	6F	FL002	14	22,28	21,14	25,0	13,0	-	30,5	36,0	6	0,070
		15 5M 25	6F	FL004	15	23,87	22,73	28,0	16,0	-	30,5	36,0	6	0,080
		16 5M 25	6F	FL004	16	25,46	24,32	28,0	16,5	-	30,5	36,0	6	0,100
		18 5M 25	6F	FL006	18	28,65	27,51	32,0	20,0	-	30,5	36,0	6	0,120
		20 5M 25	6F	FL008	20	31,83	30,69	36,0	23,0	-	30,5	36,0	6	0,160
		21 5M 25	6F	FL009	21	33,42	32,28	38,0	24,0	-	30,5	38,5	6	0,190
		22 5M 25	6F	FL015	22	35,01	33,87	39,0	25,5	-	30,5	38,5	6	0,210
		24 5M 25	6F	FL013	24	38,20	37,06	42,0	27,0	-	30,5	38,5	6	0,250
		26 5M 25	6F	FL012	26	41,38	40,24	44,0	30,0	-	30,5	38,5	6	0,300
		28 5M 25	6F	FL011	28	44,56	43,42	48,0	30,5	-	30,5	38,5	6	0,350
		30 5M 25	6F	FL016	30	47,75	46,60	51,0	35,0	-	30,5	38,5	6	0,420
		32 5M 25	6F	FL018	32	50,93	49,79	54,0	38,0	-	30,5	38,5	8	0,480
		36 5M 25	6F	FL021	36	57,30	56,16	60,0	38,0	-	30,5	38,5	8	0,590
40 5M 25	6F	FL025	40	63,66	62,52	71,0	38,0	-	30,5	38,5	8	0,740		
Alluminio / Aluminium Aluminium / Aluminium Aluminio	senza flangia / without flanges / ohne Flanschen sans flasques / sin tapetas	44 5M 25	6W	-	44	70,03	68,89	-	38,0	54	30,5	40,5	8	0,320
		48 5M 25	6W	-	48	76,39	75,25	-	45,0	61	30,5	40,5	8	0,275
		60 5M 25	6W	-	60	95,46	94,35	-	45,0	80	30,5	40,5	8	0,435
		72 5M 25	6W	-	72	114,59	113,45	-	45,0	100	30,5	40,5	8	0,525

PULEGGE DENTATE PER CINGHIE CON PROFILO HTD TIMING BELT PULLEYS HTD PROFILE

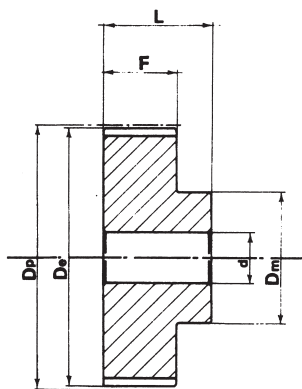

**Tipo / Type
6**

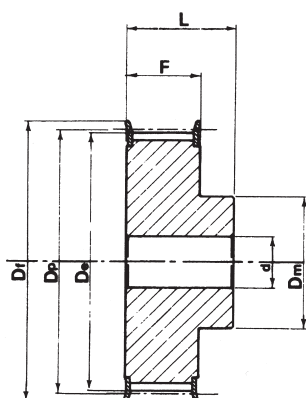

**Tipo / Type
6F**

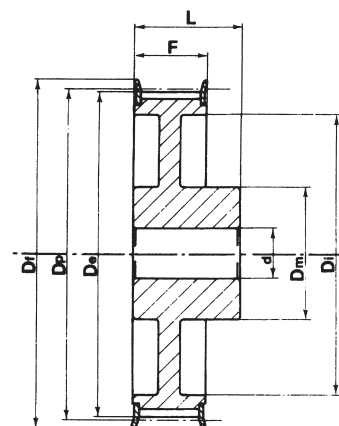

**Tipo / Type
6WF**

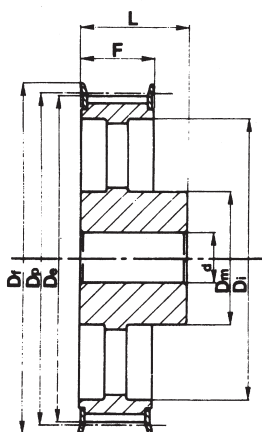

**Tipo / Type
6AF**

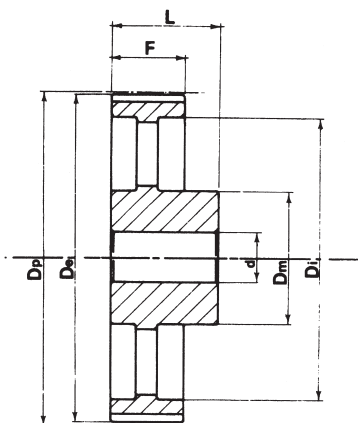

**Tipo / Type
6A**

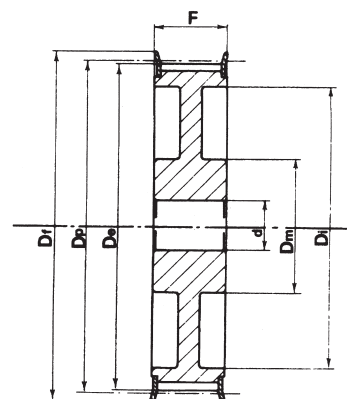

**Tipo / Type
10WF**

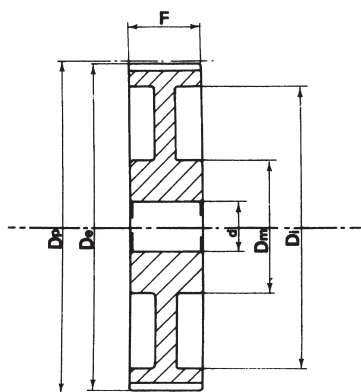

**Tipo / Type
10W**

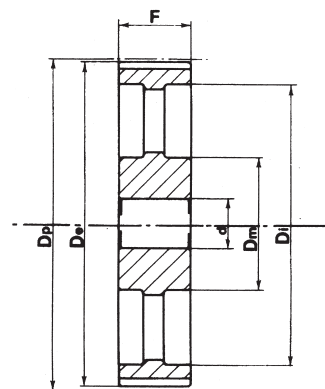

**Tipo / Type
10A**

PULEGGE DENTATE PER CINGHIE CON PROFILO HTD TIMING BELT PULLEYS HTD PROFILE

HTD Profile 8M-20

Caratteristiche Features Merkmale Características	Descrizione Description Beschreibung Description Descripción	Tipo Type Typ Type Tipo	Codice flangia Flange code Bordscheiben Typ Code flasque Código brida	N. denti N. of teeth / Zähnezahl N. bre de dents Cantidad de dientes	Dp	De	Df	Dm	Di	F	L	d	Peso Weight / Gewicht Poids / Peso Kg	
Acciaio / Steel / Stahl Acier / Acero	con flangia / with flanges mit Flanges / avec flasques con tapetas	22 8M 20	6F	FL053	22	56,02	54,65	60,0	43,0	-	28	38	12	0,54
		24 8M 20	6F	FL069	24	61,12	59,75	66,0	45,0	-	28	38	12	0,65
		26 8M 20	6F	FL061	26	66,21	64,84	70,0	48,0	-	28	38	12	0,80
		28 8M 20	6F	FL079	28	71,30	69,93	75,0	50,0	-	28	38	15	0,87
		30 8M 20	6F	FL073	30	76,39	75,02	83,0	55,0	-	28	38	15	1,02
		32 8M 20	6F	FL076	32	81,49	80,16	87,0	60,0	-	28	38	15	1,20
		34 8M 20	6F	FL066	34	86,58	85,22	91,0	70,0	-	28	38	15	1,40
		36 8M 20	6F	FL068	36	91,67	90,30	97,0	75,0	-	28	38	15	1,55
		38 8M 20	6F	FL070	38	96,77	95,39	102,0	75,0	-	28	38	15	1,65
		40 8M 20	6F	FL077	40	101,86	100,49	106,0	75,0	-	28	38	15	1,74
		44 8M 20	6F	FL075	44	112,05	110,67	120,0	75,0	-	28	38	15	2,10
		48 8M 20	6F	FL078	48	122,23	120,86	128,0	75,0	-	28	38	15	2,44
		56 8M 20	6WF	FL085	56	142,60	141,23	150,0	80,0	116	28	38	15	2,60
		64 8M 20	6WF	FL090	64	162,97	161,60	168,0	80,0	137	28	38	15	2,90
		72 8M 20	6WF	FL097	72	183,35	181,97	192,0	80,0	158	28	38	15	3,10
Ghisa / Cast iron Grauguss / Fonte Hierro fundido	senza flangia / without flanges / ohne Flanschen sans flasques / sin tapetas	80 8M 20	6W	-	80	203,72	202,35	-	90,0	180	28	38	15	3,80
		90 8M 20	6A	-	90	229,18	227,81	-	90,0	204	28	38	15	4,20
		112 8M 20	6A	-	112	285,21	283,83	-	90,0	254	28	38	18	5,20
		144 8M 20	6A	-	144	366,69	365,32	-	90,0	336	28	38	20	7,50
		168 8M 20	6A	-	168	427,81	426,44	-	100,0	400	28	38	20	10,00
		192 8M 20	6A	-	192	488,92	487,55	-	100,0	460	28	38	20	14,40

HTD Profile 8M 30

Caratteristiche Features Merkmale Características	Descrizione Description Beschreibung Description Descripción	Tipo Type Typ Type Tipo	Codice flangia Flange code Bordscheiben Typ Code flasque Código brida	N. denti N. of teeth / Zähnezahl N. bre de dents Cantidad de dientes	Dp	De	Df	Dm	Di	F	L	d	Peso Weight / Gewicht Poids / Peso Kg	
Acciaio / Steel / Stahl Acier / Acero	con flangia / with flanges mit Flanges / avec flasques con tapetas	22 8M 30	6F	FL053	22	56,02	54,65	60,0	43,0	-	38	48	12	0,69
		24 8M 30	6F	FL069	24	61,12	59,75	66,0	45,0	-	38	48	12	0,84
		26 8M 30	6F	FL061	26	66,21	64,84	70,0	48,0	-	38	48	12	1,00
		28 8M 30	6F	FL079	28	71,30	69,93	75,0	50,0	-	38	48	15	1,12
		30 8M 30	6F	FL073	30	76,39	75,02	83,0	55,0	-	38	48	15	1,32
		32 8M 30	6F	FL076	32	81,49	80,16	87,0	60,0	-	38	48	15	1,53
		34 8M 30	6F	FL066	34	86,58	85,22	91,0	70,0	-	38	48	15	1,80
		36 8M 30	6F	FL068	36	91,67	90,30	97,0	75,0	-	38	48	15	1,99
		38 8M 30	6F	FL070	38	96,77	95,39	102,0	75,0	-	38	48	15	2,27
		40 8M 30	6F	FL077	40	101,86	100,49	106,0	75,0	-	38	48	15	2,40
		44 8M 30	6F	FL075	44	112,05	110,67	120,0	75,0	-	38	48	15	2,80
		48 8M 30	6F	FL078	48	122,23	120,86	128,0	75,0	-	38	48	15	3,20
		56 8M 30	6WF	FL085	56	142,60	141,23	150,0	90,0	116	38	48	15	3,60
		64 8M 30	6WF	FL090	64	162,97	161,60	168,0	90,0	137	38	48	15	4,30
		72 8M 30	6WF	FL097	72	183,35	181,97	192,0	95,0	158	38	48	15	4,80
Ghisa / Cast iron Grauguss / Fonte Hierro fundido	senza flangia / without flanges / ohne Flanschen sans flasques / sin tapetas	80 8M 30	6W	-	80	203,72	202,35	-	100,0	180	38	48	15	5,10
		90 8M 30	6A	-	90	229,18	227,81	-	100,0	204	38	48	15	5,70
		112 8M 30	6A	-	112	285,21	283,83	-	100,0	254	38	48	18	6,80
		144 8M 30	6A	-	144	366,69	365,32	-	100,0	336	38	48	20	9,30
		168 8M 30	6A	-	168	427,81	426,44	-	100,0	400	38	48	20	11,40
		192 8M 30	6A	-	192	488,92	487,55	-	100,0	460	38	48	20	16,00

PULEGGE DENTATE PER CINGHIE CON PROFILO HTD TIMING BELT PULLEYS HTD PROFILE

HTD Profile 8M-50

Caratteristiche Features Merkmale Características Características	Descrizione Description Beschreibung Description Descripción	Tipo Type Typ Type Tipo	Codice flangia Flange code Bordscheiben Typ Code flasque Código brida	N. denti N. of teeth / Zähnezahl N. bre de dents Cantidad de dientes	Dp	De	Df	Dm	Di	F	L	d	Peso Weight / Gewicht Poids / Peso Kg	
Acciaio / Steel / Stahl Acier / Acero	con flangia / with flanges mit Flanges / avec flasques con tapetas	22 8M 50	6F	FL053	22	56,02	54,65	60,0	43,0	-	60	70	12	1,00
		24 8M 50	6F	FL069	24	61,12	59,75	66,0	45,0	-	60	70	12	1,23
		26 8M 50	6F	FL061	26	66,21	64,84	70,0	48,0	-	60	70	15	1,50
		28 8M 50	6F	FL079	28	71,30	69,93	75,0	50,0	-	60	70	15	1,67
		30 8M 50	6F	FL073	30	76,39	75,02	83,0	55,0	-	60	70	15	1,97
		32 8M 50	6F	FL076	32	81,49	80,16	87,0	60,0	-	60	70	15	2,27
		34 8M 50	6F	FL066	34	86,58	85,22	91,0	70,0	-	60	70	15	2,69
		36 8M 50	6F	FL068	36	91,67	90,30	97,0	75,0	-	60	70	15	2,97
		38 8M 50	6F	FL070	38	96,77	95,39	102,0	75,0	-	60	70	15	3,23
		40 8M 50	6F	FL077	40	101,86	100,49	106,0	75,0	-	60	70	18	3,50
		44 8M 50	6F	FL075	44	112,05	110,67	120,0	75,0	-	60	70	18	3,90
		48 8M 50	6F	FL078	48	122,23	120,86	128,0	75,0	-	60	70	18	4,30
		56 8M 50	10WF	FL085	56	142,60	141,23	150,0	80,0	116	60	60	18	5,00
		64 8M 50	10WF	FL090	64	162,97	161,60	168,0	80,0	137	60	60	18	5,60
		72 8M 50	10WF	FL097	72	183,35	181,97	192,0	80,0	158	60	60	18	6,80
Ghisa / Cast iron Grauguss / Fonte Hierro fundido	senza flangia / without flanges / ohne Flanschen sans flasques / sin tapetas	80 8M 50	10W	-	80	203,72	202,35	-	110,0	180	60	60	18	6,90
		90 8M 50	10A	-	90	229,18	227,81	-	110,0	204	60	60	18	8,60
		112 8M 50	10A	-	112	285,21	283,83	-	110,0	254	60	60	18	9,60
		144 8M 50	10A	-	144	366,69	365,32	-	110,0	336	60	60	20	13,80
		168 8M 50	10A	-	168	427,81	426,44	-	120,0	400	60	60	20	16,00
		192 8M 50	10A	-	192	488,92	487,55	-	130,0	460	60	60	20	22,40

HTD Profile 8M-85

Caratteristiche Features Merkmale Características Características	Descrizione Description Beschreibung Description Descripción	Tipo Type Typ Type Tipo	Codice flangia Flange code Bordscheiben Typ Code flasque Código brida	N. denti N. of teeth / Zähnezahl N. bre de dents Cantidad de dientes	Dp	De	Df	Dm	Di	F	L	d	Peso Weight / Gewicht Poids / Peso Kg	
Acciaio / Steel / Stahl Acier / Acero	con flangia / with flanges mit Flanges / avec flasques con tapetas	22 8M 85	6F	FL053	22	56,02	54,65	60,0	43,0	-	95	105	12	1,55
		24 8M 85	6F	FL069	24	61,12	59,75	66,0	45,0	-	95	105	12	1,90
		26 8M 85	6F	FL061	26	66,21	64,84	70,0	48,0	-	95	105	12	2,25
		28 8M 85	6F	FL079	28	71,30	69,93	75,0	50,0	-	95	105	15	2,55
		30 8M 85	6F	FL073	30	76,39	75,02	83,0	55,0	-	95	105	15	3,00
		32 8M 85	6F	FL076	32	81,49	80,16	87,0	60,0	-	95	105	15	3,57
		34 8M 85	6F	FL066	34	86,58	85,22	91,0	66,0	-	95	105	15	4,00
		36 8M 85	6F	FL068	36	91,67	90,30	97,0	70,0	-	95	105	15	4,50
		38 8M 85	6F	FL070	38	96,77	95,39	102,0	75,0	-	95	105	15	5,00
		40 8M 85	6F	FL077	40	101,86	100,49	106,0	75,0	-	95	105	18	5,20
		44 8M 85	6F	FL075	44	112,05	110,67	120,0	75,0	-	95	105	18	6,60
		48 8M 85	6F	FL078	48	122,23	120,86	128,0	80,0	-	95	105	18	7,00
		56 8M 85	6F	FL085	56	142,60	141,23	150,0	90,0	-	95	105	18	10,00
		64 8M 85	10WF	FL090	64	162,97	161,60	168,0	100,0	137	95	95	20	10,40
		72 8M 85	10WF	FL097	72	183,35	181,97	192,0	100,0	158	95	95	20	11,40
Ghisa / Cast iron Grauguss / Fonte Hierro fundido	senza flangia / without flanges / ohne Flanschen sans flasques / sin tapetas	80 8M 85	10W	-	80	203,72	202,35	-	110,0	180	95	95	20	11,10
		90 8M 85	10A	-	90	229,18	227,81	-	110,0	204	95	95	20	12,20
		112 8M 85	10A	-	112	285,21	283,83	-	110,0	254	95	95	24	15,00
		144 8M 85	10A	-	144	366,69	365,32	-	110,0	336	95	95	24	21,50
		168 8M 85	10A	-	168	427,81	426,44	-	120,0	400	95	95	24	24,10
		192 8M 85	10A	-	192	488,92	487,55	-	130,0	460	95	95	24	30,60

PULEGGE DENTATE PER CINGHIE CON PROFILO HTD TIMING BELT PULLEYS HTD PROFILE

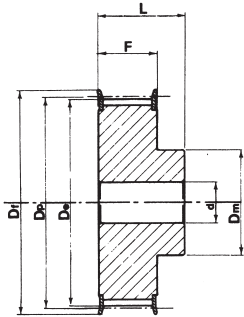

**Tipo / Type
6F**

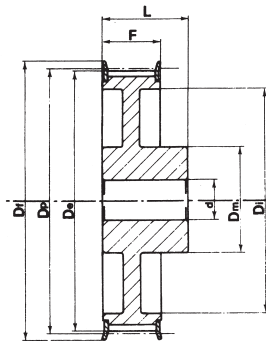

**Tipo / Type
6WF**

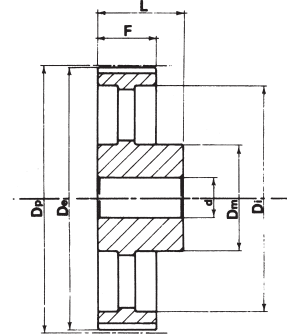

**Tipo / Type
6A**

HTD Profile 14M-40

Caratteristiche Features Merkmale Características Características	Descrizione Description Beschreibung Description Descripción	Tipo Type Typ Type Tipo	Codice flangia Flange code Bordscheiben Typ Code flasque Código brida	N. denti N. of teeth / Zähnezahl N. bre de dents Cantidad de dientes	Dp	De	Df	Dm	Di	F	L	d	Peso Weight / Gewicht Poids / Peso Kg	
Acciaio / Steel / Stahl Acier / Acero	con flangia / with flanges mit Flanges / avec flasques con tapetas	28 14M 40	6F	FL153	28	124,78	122,12	128,0	100,0	-	54	69	24	4,73
		29 14M 40	6F	FL154	29	129,23	126,57	138,0	100,0	-	54	69	24	5,09
		30 14M 40	6F	FL154	30	133,69	130,99	138,0	100,0	-	54	69	24	5,45
		32 14M 40	6F	FL160	32	142,60	139,88	154,0	100,0	-	54	69	24	6,17
		34 14M 40	6F	FL166	34	151,52	148,79	160,0	100,0	-	54	69	24	6,88
		36 14M 40	6F	FL168	36	160,43	157,68	168,0	100,0	-	54	69	24	7,60
		38 14M 40	6F	FL172	38	169,34	166,60	183,0	120,0	-	54	69	24	8,28
		40 14M 40	6F	FL162	40	178,25	175,49	188,0	120,0	-	54	69	24	9,26
		44 14M 40	6F	FL175	44	196,08	193,28	211,0	120,0	-	54	69	24	10,32
Ghisa / Cast iron Grauguss / Fonte Hierro fundido	senza flangia / without flanges / ohne Flanschen sans flasques / sin tapetas	48 14M 40	6WF	FL180	48	213,90	211,11	226,0	135,0	170	54	69	24	11,50
		56 14M 40	6WF	FL182	56	249,55	246,76	256,0	135,0	207	54	69	28	13,05
		64 14M 40	6WF	FL184	64	285,21	282,41	296,0	135,0	240	54	69	28	14,40
		72 14M 40	6A	-	72	320,86	318,06	-	135,0	280	54	69	28	16,90
		80 14M 40	6A	-	80	356,51	353,71	-	135,0	314	54	69	28	18,50
		90 14M 40	6A	-	90	401,07	398,28	-	135,0	358	54	69	28	20,00
		112 14M 40	6A	-	112	499,11	496,32	-	135,0	456	54	69	28	26,70
		144 14M 40	6A	-	144	641,71	638,92	-	135,0	600	54	69	28	35,00
		168 14M 40	6A	-	168	748,66	745,87	-	135,0	706	54	69	28	44,20
		192 14M 40	6A	-	192	855,62	852,82	-	135,0	813	54	69	28	52,20
216 14M 40	6A	-	216	962,57	959,76	-	150,0	920	54	69	28	62,50		

PULEGGE DENTATE PER CINGHIE CON PROFILO HTD TIMING BELT PULLEYS HTD PROFILE

HTD Profile 14M-55

Caratteristiche Features Merkmale Características Características	Descrizione Description Beschreibung Description Descripción	Tipo Type Typ Type Tipo	Codice flangia Flange code Bordscheiben Typ Code flasque Código brida	N. denti N. of teeth / Zähnezahl N. bre de dents Cantidad de dientes	Dp	De	Df	Dm	Di	F	L	d	Peso Weight / Gewicht Poids / Peso Kg	
Acciaio / Steel / Stahl Acier / Acero	con flangia / with flanges mit Flanges / avec flasques con tapetas	28 14M 55	6F	FL153	28	124,78	122,12	128,0	100,0	-	70	85	24	5,60
		29 14M 55	6F	FL154	29	129,23	126,57	138,0	100,0	-	70	85	24	6,10
		30 14M 55	6F	FL154	30	133,69	130,99	138,0	100,0	-	70	85	24	6,60
		32 14M 55	6F	FL160	32	142,60	139,88	154,0	100,0	-	70	85	24	7,60
		34 14M 55	6F	FL166	34	151,52	148,79	160,0	100,0	-	70	85	24	8,60
		36 14M 55	6F	FL168	36	160,43	157,68	168,0	100,0	-	70	85	24	9,60
		38 14M 55	6F	FL172	38	169,34	166,60	183,0	120,0	-	70	85	24	10,80
		40 14M 55	6F	FL162	40	178,25	175,49	188,0	120,0	-	70	85	24	11,20
		44 14M 55	6F	FL175	44	196,08	193,28	211,0	120,0	-	70	85	24	12,50
Ghisa / Cast iron Grauguss / Fonte Hierro fundido	con flangia / with flanges mit Flanges / avec flasques con tapetas	48 14M 55	10WF	FL180	48	213,90	211,11	226,0	135,0	170	70	70	24	13,70
		56 14M 55	10WF	FL182	56	249,55	246,76	256,0	135,0	207	70	70	28	14,50
		64 14M 55	10WF	FL184	64	285,21	282,41	296,0	135,0	240	70	70	28	15,60
		72 14M 55	10A	-	72	320,86	318,06	-	135,0	280	70	70	28	16,90
	senza flangia / without flanges / ohne Flanschen sans flasques / sin tapetas	80 14M 55	10A	-	80	356,51	353,71	-	135,0	314	70	70	28	20,00
		90 14M 55	10A	-	90	401,07	398,28	-	135,0	358	70	70	28	22,60
		112 14M 55	10A	-	112	499,11	496,32	-	135,0	456	70	70	28	29,50
		144 14M 55	10A	-	144	641,71	638,92	-	135,0	600	70	70	28	39,00
		168 14M 55	10A	-	168	748,66	745,87	-	135,0	706	70	70	28	48,50
		192 14M 55	10A	-	192	855,62	852,82	-	135,0	813	70	70	28	57,80
216 14M 55	10A	-	216	962,57	959,76	-	150,0	920	70	70	28	67,00		

HTD Profile 14M-85

Caratteristiche Features Merkmale Características Características	Descrizione Description Beschreibung Description Descripción	Tipo Type Typ Type Tipo	Codice flangia Flange code Bordscheiben Typ Code flasque Código brida	N. denti N. of teeth / Zähnezahl N. bre de dents Cantidad de dientes	Dp	De	Df	Dm	Di	F	L	d	Peso Weight / Gewicht Poids / Peso Kg	
Acciaio / Steel / Stahl Acier / Acero	con flangia / with flanges mit Flanges / avec flasques con tapetas	28 14M 85	6F	FL153	28	124,78	122,12	128,0	100,0	-	102	117	24	7,70
		29 14M 85	6F	FL154	29	129,23	126,57	138,0	100,0	-	102	117	24	8,40
		30 14M 85	6F	FL154	30	133,69	130,99	138,0	100,0	-	102	117	24	9,10
		32 14M 85	6F	FL160	32	142,60	139,88	154,0	100,0	-	102	117	24	10,50
		34 14M 85	6F	FL166	34	151,52	148,79	160,0	100,0	-	102	117	24	11,90
		36 14M 85	6F	FL168	36	160,43	157,68	168,0	100,0	-	102	117	32	13,20
		38 14M 85	6F	FL172	38	169,34	166,60	183,0	120,0	-	102	117	32	15,15
		40 14M 85	6F	FL162	40	178,25	175,49	188,0	135,0	-	102	117	32	17,10
		44 14M 85	6F	FL175	44	196,08	193,28	211,0	135,0	-	102	117	32	23,30
Ghisa / Cast iron Grauguss / Fonte Hierro fundido	con flangia / with flanges mit Flanges / avec flasques con tapetas	48 14M 85	6F	FL180	48	213,90	211,11	226,0	150,0	-	102	117	32	25,00
		56 14M 85	10WF	FL182	56	249,55	246,76	256,0	150,0	207	102	102	32	25,00
	senza flangia / without flanges / ohne Flanschen sans flasques / sin tapetas	64 14M 85	10WF	FL184	64	285,21	282,41	296,0	150,0	240	102	102	32	30,50
		72 14M 85	10A	-	72	320,86	318,06	-	150,0	278	102	102	32	28,80
		80 14M 85	10A	-	80	356,51	353,71	-	150,0	314	102	102	32	30,10
		90 14M 85	10A	-	90	401,07	398,28	-	150,0	358	102	102	32	33,00
		112 14M 85	10A	-	112	499,11	496,32	-	150,0	456	102	102	32	41,80
		144 14M 85	10A	-	144	641,71	638,92	-	150,0	600	102	102	32	52,40
		168 14M 85	10A	-	168	748,66	745,87	-	150,0	706	102	102	32	60,30
		192 14M 85	10A	-	192	855,62	852,82	-	165,0	813	102	102	32	70,20
216 14M 85	10A	-	216	962,57	959,76	-	160,0	920	102	102	32	81,00		

PULEGGE DENTATE PER CINGHIE CON PROFILO HTD TIMING BELT PULLEYS HTD PROFILE

HTD Profile 14M-115

Caratteristiche Features Merkmal Características Características	Descrizione Description Beschreibung Description Descripción	Tipo Type Typ Type Tipo	Codice flangia Flange code Bordscheiben Typ Code flasque Código brida	N. denti N. of teeth / Zähnezahl N. bre de dents Cantidad de dientes	Dp	De	Df	Dm	Di	F	L	d	Peso Weight / Gewicht Poids / Peso Kg	
Acciaio / Steel / Stahl Acier / Acero	con flangia / with flanges mit Flanges / avec flasques con tapetas	28 14M 115	6F	FL153	28	124,78	122,12	128,0	100,0	-	133	148	32	9,20
		29 14M 115	6F	FL154	29	129,23	126,57	138,0	100,0	-	133	148	32	10,20
		30 14M 115	6F	FL154	30	133,69	130,99	138,0	100,0	-	133	148	32	11,20
		32 14M 115	6F	FL160	32	142,60	139,88	154,0	100,0	-	133	148	32	13,20
		34 14M 115	6F	FL166	34	151,52	148,79	160,0	100,0	-	133	148	32	14,80
		36 14M 115	6F	FL168	36	160,43	157,68	168,0	100,0	-	133	148	32	16,60
		38 14M 115	6F	FL172	38	169,34	166,60	183,0	120,0	-	133	148	32	19,20
		40 14M 115	6F	FL162	40	178,25	175,49	188,0	135,0	-	133	148	32	20,56
		44 14M 115	6F	FL175	44	196,08	193,28	211,0	140,0	-	133	148	32	21,93
		48 14M 115	6F	FL180	48	213,90	211,11	226,0	150,0	-	133	148	32	25,00
		56 14M 115	6F	FL182	56	249,55	246,76	256,0	150,0	-	133	148	32	27,50
		64 14M 115	10WF	FL184	64	285,21	282,41	296,0	150,0	240	133	133	32	30,10
Ghisa / Cast iron Grauguss / Fonte Hierro fundido	senza flangia / without flanges / ohne Flanschen sans flasques / sin tapetas	72 14M 115	10A	-	72	320,86	318,06	-	150,0	278	133	133	32	32,83
		80 14M 115	10A	-	80	356,51	353,71	-	150,0	314	133	133	32	35,55
		90 14M 115	10A	-	90	401,07	398,28	-	150,0	358	133	133	32	41,00
		112 14M 115	10A	-	112	499,11	496,32	-	150,0	456	133	133	32	54,40
		144 14M 115	10A	-	144	641,71	638,92	-	165,0	600	133	133	32	67,80
		168 14M 115	10A	-	168	748,66	745,87	-	165,0	706	133	133	32	75,80
		192 14M 115	10A	-	192	855,62	852,82	-	165,0	813	133	133	32	88,30
		216 14M 115	10A	-	216	962,57	959,76	-	165,0	920	133	133	32	98,00

HTD Profile 14M-170

Caratteristiche Features Merkmal Características Características	Descrizione Description Beschreibung Description Descripción	Tipo Type Typ Type Tipo	Codice flangia Flange code Bordscheiben Typ Code flasque Código brida	N. denti N. of teeth / Zähnezahl N. bre de dents Cantidad de dientes	Dp	De	Df	Dm	Di	F	L	d	Peso Weight / Gewicht Poids / Peso Kg	
Acciaio / Steel / Stahl Acier / Acero	con flangia / with flanges mit Flanges / avec flasques con tapetas	28 14M 170	6F	FL153	28	124,78	122,12	128,0	100,0	-	187	202	32	9,20
		29 14M 170	6F	FL154	29	129,23	126,57	138,0	100,0	-	187	202	32	10,20
		30 14M 170	6F	FL154	30	133,69	130,99	138,0	100,0	-	187	202	32	11,20
		32 14M 170	6F	FL160	32	142,60	139,88	154,0	100,0	-	187	202	32	13,20
		34 14M 170	6F	FL166	34	151,52	148,79	160,0	100,0	-	187	202	32	14,80
		36 14M 170	6F	FL168	36	160,43	157,68	168,0	100,0	-	187	202	32	16,60
		38 14M 170	6F	FL172	38	169,34	166,60	183,0	120,0	-	187	202	32	19,20
		40 14M 170	6F	FL162	40	178,25	175,49	188,0	135,0	-	187	202	32	20,56
		44 14M 170	6F	FL175	44	196,08	193,28	211,0	140,0	-	187	202	32	21,93
		48 14M 170	6F	FL180	48	213,90	211,11	226,0	150,0	-	187	202	32	25,00
		56 14M 170	6F	FL182	56	249,55	246,76	256,0	150,0	-	187	202	32	27,50
		64 14M 170	10WF	FL184	64	285,21	282,41	296,0	150,0	240	187	187	32	30,10
Ghisa / Cast iron Grauguss / Fonte Hierro fundido	senza flangia / without flanges / ohne Flanschen sans flasques / sin tapetas	72 14M 170	10A	-	72	320,86	318,06	-	150,0	278	187	187	32	32,83
		80 14M 170	10A	-	80	356,51	353,71	-	150,0	314	187	187	32	35,55
		90 14M 170	10A	-	90	401,07	398,28	-	150,0	358	187	187	32	41,00
		112 14M 170	10A	-	112	499,11	496,32	-	150,0	456	187	187	32	54,40
		144 14M 170	10A	-	144	641,71	638,92	-	165,0	600	187	187	32	67,80
		168 14M 170	10A	-	168	748,66	745,87	-	165,0	706	187	187	32	75,80
		192 14M 170	10A	-	192	855,62	852,82	-	165,0	813	187	187	32	88,30
		216 14M 170	10A	-	216	962,57	959,76	-	165,0	920	187	187	32	98,00

BARRE DENTATE CON PROFILO HTD HTD PROFILE STANDARD TOOTHED BARS

Materiale:
alluminio 6082 T6
UNI 9006/4 adatto al
trattamento anodico

Material:
aluminium 6082 T6
UNI 9006/4 suitable for
anodic treatment

Werkstoff:
aluminium 6082 T6
UNI 9006/4 geeignet für
anodischen oxydation

Matière:
aluminium 6082 T6
UNI 9006/4 apte au
traitement anodique

Material:
aluminio 6082 T6
UNI 9006/4 apto para la
oxidación anodica

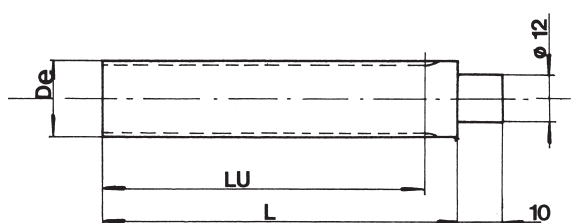
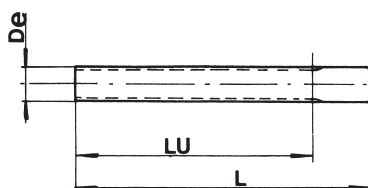

HTD Profile 3M

Descrizione Description Beschreibung Description Descripción	N. denti N. of teeth / Zähnezahl N. bre de dents Cantidad de dientes	Dp	De	Lu	L
9 3M	9	8,59	7,83	75	100
10 3M	10	9,55	8,79	75	100
11 3M	11	10,50	9,74	75	100
12 3M	12	11,46	10,70	100	125
13 3M	13	12,41	11,65	100	125
14 3M	14	13,37	12,61	100	125
15 3M	15	14,32	13,56	100	125
16 3M	16	15,28	14,52	125	155
17 3M	17	16,23	15,47	125	155
18 3M	18	17,19	16,43	125	155
19 3M	19	18,14	17,38	125	155
20 3M	20	19,10	18,34	150	165
21 3M	21	20,05	19,25	150	165
22 3M	22	21,01	20,25	150	165
23 3M	23	21,96	21,20	150	165
24 3M	24	22,92	22,16	150	165
25 3M	25	23,87	23,11	150	165
26 3M	26	24,83	24,07	150	165
27 3M	27	25,78	25,02	150	165
28 3M	28	26,74	25,98	150	165
29 3M	29	27,69	26,93	150	165
30 3M	30	28,65	27,89	175	183
31 3M	31	29,60	28,84	175	183
32 3M	32	30,56	29,80	175	183
33 3M	33	31,54	30,75	175	183
34 3M	34	32,47	31,71	175	183
35 3M	35	33,42	32,66	175	183
36 3M	36	34,38	33,62	200	200
37 3M	37	35,33	34,57	200	200
38 3M	38	36,29	35,53	200	200
39 3M	39	37,24	36,48	200	200
40 3M	40	38,20	37,44	200	200
42 3M	42	40,11	39,34	200	200
44 3M	44	42,02	41,26	200	200
45 3M	45	42,97	42,21	200	200
48 3M	48	45,84	45,08	200	200
50 3M	50	47,75	46,99	200	200
52 3M	52	49,66	48,90	200	200
54 3M	54	51,57	50,81	200	200
56 3M	56	53,48	52,72	200	200
60 3M	60	57,30	56,54	200	200
62 3M	62	59,21	58,45	200	200
64 3M	64	61,12	60,36	200	200
66 3M	66	63,03	62,27	200	200
68 3M	68	64,94	64,18	200	200
70 3M	70	66,85	66,09	200	200
72 3M	72	68,75	67,99	200	200

HTD Profile 5M

Descrizione Description Beschreibung Description Descripción	N. denti N. of teeth / Zähnezahl N. bre de dents Cantidad de dientes	Dp	De	Lu	L
12 - 5M	12	19,10	17,96	150	165
13 - 5M	13	20,69	19,55	150	165
14 - 5M	14	22,28	21,14	175	183
15 - 5M	15	23,87	22,73	175	183
16 - 5M	16	25,46	24,32	175	183
17 - 5M	17	27,06	25,92	175	183
18 - 5M	18	28,65	27,51	200	200
19 - 5M	19	30,24	29,10	200	200
20 - 5M	20	31,83	30,69	200	200
21 - 5M	21	33,42	32,28	200	200
22 - 5M	22	35,01	33,87	200	200
23 - 5M	23	36,61	35,47	200	200
24 - 5M	24	38,20	37,06	200	200
25 - 5M	25	39,79	38,65	200	200
26 - 5M	26	41,38	40,24	200	200
27 - 5M	27	42,97	41,83	200	200
28 - 5M	28	44,56	43,42	200	200
29 - 5M	29	46,15	45,01	200	200
30 - 5M	30	47,75	46,60	200	200
31 - 5M	31	49,34	48,20	200	200
32 - 5M	32	50,93	49,79	200	200
33 - 5M	33	52,52	51,38	200	200
34 - 5M	34	54,11	52,97	200	200
35 - 5M	35	55,70	54,56	200	200
36 - 5M	36	57,30	56,16	200	200
38 - 5M	38	60,48	59,34	200	200
40 - 5M	40	63,66	62,52	200	200
42 - 5M	42	66,85	65,71	200	200
44 - 5M	44	70,03	68,89	200	200
45 - 5M	45	71,62	70,48	200	200
46 - 5M	46	73,21	72,07	200	200
48 - 5M	48	76,39	75,25	200	200
50 - 5M	50	79,58	78,43	200	200
54 - 5M	54	85,94	84,80	200	200
60 - 5M	60	95,49	94,35	200	200
62 - 5M	62	98,68	97,54	200	200
72 - 5M	72	114,59	113,45	200	200

PULLEGGE DENTATE CON PROFILO HTD PER BUSSOLA CONICA
HTD PROFILE TIMING BELT PULLEYS FOR TAPER BUSHES



PULEGGE DENTATE CON PROFILO HTD PER BUSSOLA CONICA HTD PROFILE TIMING BELT PULLEYS FOR TAPER BUSHES

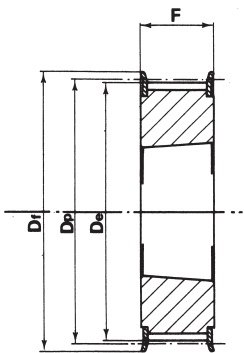

Tipo / Type
3F

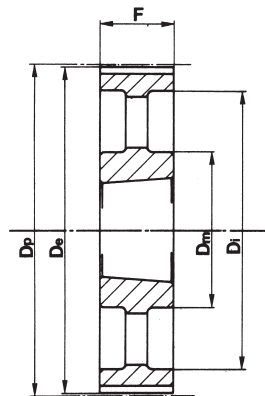

Tipo / Type
3A

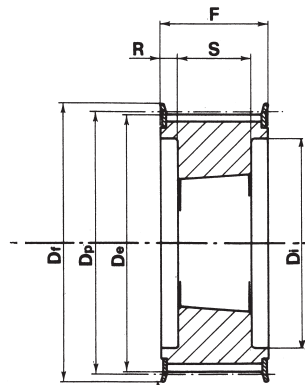

Tipo / Type
4F

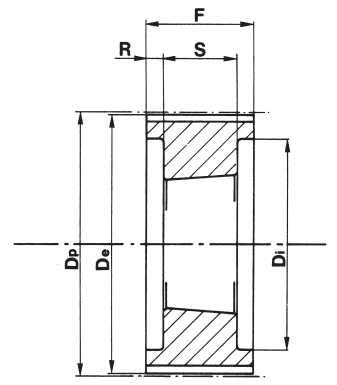

Tipo / Type
4

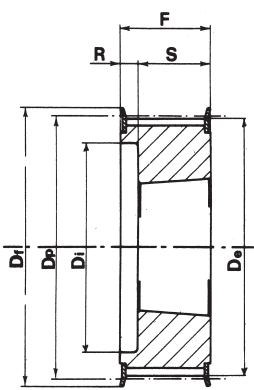

Tipo / Type
5F

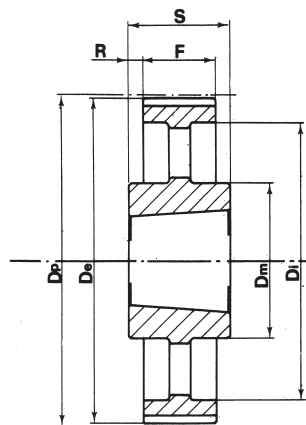

Tipo / Type
7A

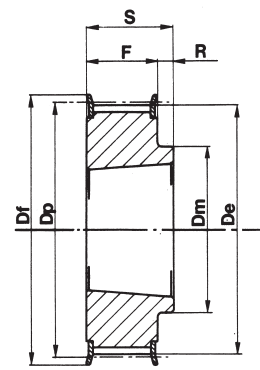

Tipo / Type
8F

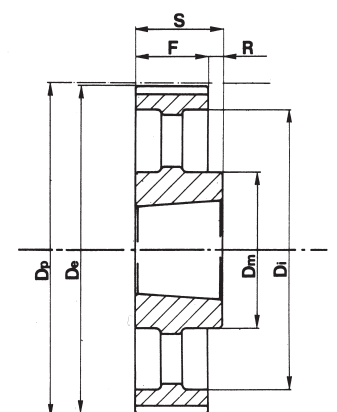

Tipo / Type
8A

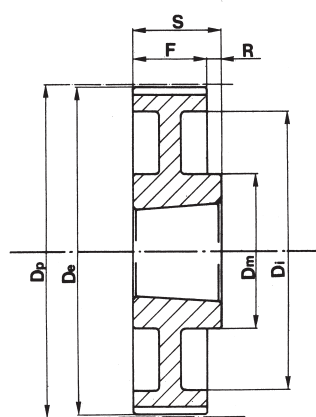

Tipo / Type
8W

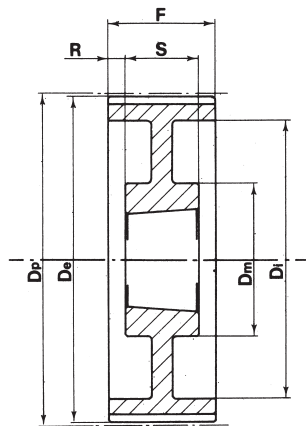

Tipo / Type
9W

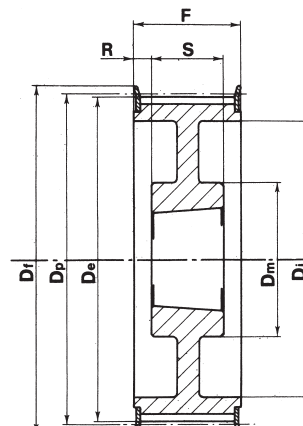

Tipo / Type
9WF

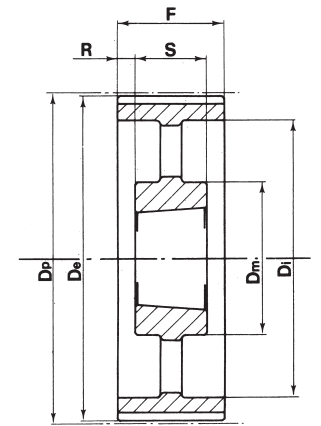

Tipo / Type
9A

PULEGGE DENTATE CON PROFILO HTD PER BUSSOLA CONICA HTD PROFILE TIMING BELT PULLEYS FOR TAPER BUSHES

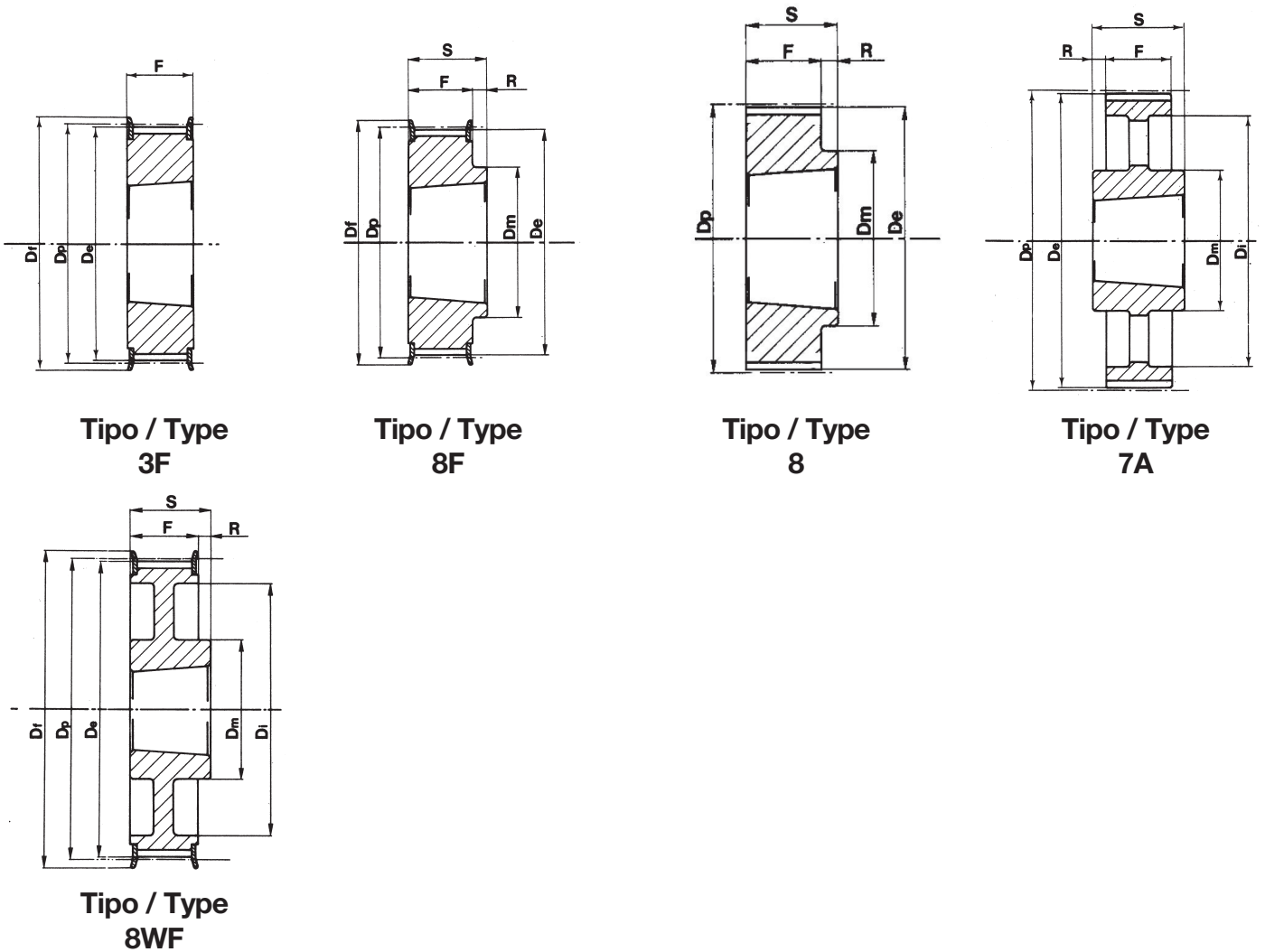

HTD Profile 5M-15

Caratteristiche Features Merkmale Características Características	Descrizione Description Beschreibung Description Descripción	Tipo Type Typ Type Tipo	Codice flangia Flange code Bordscheiben Typ Code flasque Moyeu Código brida	Bussola Bush Buchse Moyeu Casquillo	Foro max. Max. Bore Max. Bohrung Alésage max. Agujero max.	Dp	De	Df	Dm	Di	F	S	R	Peso Weight / Gewicht Poids / Peso Kg	
Acciaio / Steel / Stahl Acier / Acero	con flangia / with flanges mit Flanges / avec flasques / con tapetas	34 5M 15	3F	FL020	1008	25	54,11	52,97	57,0	-	22	22	-	0,19	
	36 5M 15	3F	FL021	1108	25	57,30	56,15	60,0	-	22	22	-	0,20		
	38 5M 15	3F	FL024	1108	25	60,48	59,34	66,5	-	22	22	-	0,26		
	40 5M 15	3F	FL025	1108	25	63,66	62,52	71,0	-	22	22	-	0,31		
	44 5M 15	3F	FL027	1108	25	70,03	68,89	75,0	-	22	22	-	0,41		
	48 5M 15	8F	FL029	1210	32	76,39	75,25	83,0	59	-	22	25	3	0,45	
	56 5M 15	8F	FL033	1210	32	89,13	87,98	93,0	70	-	22	25	3	0,75	
	64 5M 15	8F	FL038	1210	32	101,86	100,72	106,0	80	-	22	25	3	1,20	
	senza flangia / without flanges ohne Flanschen / sans flasques sin tapetas	72 5M 15	8	-	1610	42	114,59	113,45	-	92	-	22	25	3	1,35
	80 5M 15	8	-	1610	42	127,32	126,18	-	92	-	22	25	3	1,73	
90 5M 15	8	-	1610	42	143,24	142,10	-	92	-	22	25	3	2,29		
112 5M 15	8	-	2012	50	178,25	177,11	-	110	-	20	32	12	3,71		
136 5M 15	7A	-	2012	50	216,45	215,31	-	110	199	20	32	6	3,08		

PULEGGE DENTATE CON PROFILO HTD PER BUSSOLA CONICA HTD PROFILE TIMING BELT PULLEYS FOR TAPER BUSHES

HTD Profile 8M-20

Caratteristiche Features Merkmale Características	Descrizione Description Beschreibung Description Descripción	Tipo Type Typ Type Tipo	Codice flangia Flange code Bordscheiben Typ Code flasque Código brida	Bussola Bush Buchse Moyeu Casquillo	Foro max. Max. Bore Max. Bohrung Alesage max. Agujero max.	Dp	De	Df	Dm	Di	F	S	R	Peso Weight / Gewicht Poids / Peso Kg	
Acciaio / Steel / Stahl Acier / Acero	con flangia / with flanges mit Flanges / avec flasques / con tapetas	22-8M-20	5F	FL053	1008	25	56,02	54,65	60,0	-	37	28	22	6	0,25
		24 8M 20	5F	FL069	1108	25	61,12	59,75	66,0	-	44	28	22	6	0,30
		26 8M 20	5F	FL061	1108	25	66,21	64,84	70,0	-	45	28	22	6	0,36
		28 8M 20	5F	FL079	1108	25	71,30	69,93	75,0	-	50	28	22	6	0,44
		30 8M 20	5F	FL073	1108	25	76,39	75,02	83,0	-	58	28	22	6	0,53
		32 8M 20	5F	FL076	1610	42	81,49	80,16	87,0	-	63	28	25	3	0,42
		34 8M 20	5F	FL066	1610	42	86,58	85,22	91,0	-	64	28	25	3	0,55
		36 8M 20	5F	FL068	1610	42	91,67	90,30	97,0	-	68	28	25	3	0,68
		38 8M 20	5F	FL070	1610	42	96,77	95,39	102,0	-	72	28	25	3	0,80
		40 8M 20	5F	FL077	1610	42	101,86	100,49	106,0	-	76	28	25	3	1,00
		44 8M 20	8F	FL075	2012	50	112,05	110,67	120,0	93	-	28	32	4	1,20
		48 8M 20	8F	FL078	2012	50	122,23	120,86	128,0	96	-	28	32	4	1,60
		56 8M 20	8F	FL085	2012	50	142,60	141,23	150,0	110	-	28	32	4	2,40
		64 8M 20	8F	FL090	2012	50	162,97	161,60	168,0	110	137	28	32	4	2,70
72 8M 20	8F	FL097	2012	50	183,35	181,97	192,0	110	158	28	32	4	3,30		
Ghisa / Cast iron Grauguss / Fonte Hierro fundido	senza flangia / without flanges ohne Flanschen / sans flasques sin tapetas	80 8M 20	8W	-	2012	50	203,72	202,35	-	110	180	28	32	4	3,50
		90 8M 20	8A	-	2012	50	229,18	227,81	-	110	204	28	32	4	3,65
		144 8M 20	8A	-	2517	60	366,69	365,32	-	125	336	28	45	17	4,80

HTD Profile 8M-30

Caratteristiche Features Merkmale Características	Descrizione Description Beschreibung Description Descripción	Tipo Type Typ Type Tipo	Codice flangia Flange code Bordscheiben Typ Code flasque Código brida	Bussola Bush Buchse Moyeu Casquillo	Foro max. Max. Bore Max. Bohrung Alesage max. Agujero max.	Dp	De	Df	Dm	Di	F	S	R	Peso Weight / Gewicht Poids / Peso Kg	
Acciaio / Steel / Stahl Acier / Acero	con flangia / with flanges mit Flanges / avec flasques / con tapetas	22 8M 30	5F	FL053	1008	25	56,02	54,65	60,0	-	37	38	22	16	0,31
		24 8M 30	5F	FL069	1108	25	61,12	59,75	66,0	-	44	38	22	16	0,38
		26 8M 30	5F	FL061	1108	25	66,21	64,84	70,0	-	44	38	22	16	0,45
		28 8M 30	5F	FL079	1210	32	71,30	69,93	75,0	-	50	38	25	13	0,50
		30 8M 30	3F	FL073	1615	42	76,39	75,02	83,0	-	-	38	38	-	0,55
		32 8M 30	3F	FL076	1615	42	81,49	80,16	87,0	-	-	38	38	-	0,59
		34 8M 30	3F	FL066	1615	42	86,58	85,22	91,0	-	-	38	38	-	0,77
		36 8M 30	3F	FL068	1615	42	91,67	90,30	97,0	-	-	38	38	-	0,96
		38 8M 30	3F	FL070	1615	42	96,77	95,39	102,0	-	-	38	38	-	1,15
		40 8M 30	3F	FL077	1615	42	101,86	100,49	106,0	-	-	38	38	-	1,34
		44 8M 30	4F	FL075	2012	50	112,05	110,67	120,0	-	86	38	32	3	1,33
		48 8M 30	4F	FL078	2012	50	122,23	120,86	128,0	-	90	38	32	3	1,78
		56 8M 30	4F	FL085	2012	50	142,60	141,23	150,0	-	110	38	32	3	3,76
		64 8M 30	8F	FL090	2517	60	162,97	161,60	168,0	125	-	38	45	7	4,20
72 8M 30	8F	FL097	2517	60	183,35	181,97	192,0	125	158	38	45	7	4,30		
Ghisa / Cast iron Grauguss / Fonte Hierro fundido	senza flangia / without flanges ohne Flanschen / sans flasques sin tapetas	80 8M 30	8W	-	2517	60	203,72	202,35	-	125	180	38	45	7	4,60
		90 8M 30	8A	-	2517	60	229,18	227,81	-	125	204	38	45	7	5,00
		112 8M 30	8A	-	2517	60	285,21	283,83	-	125	254	38	45	7	6,20
		144 8M 30	8A	-	2517	60	366,69	365,32	-	125	336	38	45	7	9,00

PULEGGE DENTATE CON PROFILO HTD PER BUSSOLA CONICA HTD PROFILE TIMING BELT PULLEYS FOR TAPER BUSHES

HTD Profile 8M-50

Caratteristiche Features Merkmale Características	Descrizione Description Beschreibung Description Descripción	Tipo Type Typ Type Tipo	Codice flangia Flange code Bordscheiben Typ Code flasque Código brida	Bussola Bush Buchse Moyeu Casquillo	Foro max. Max. Bore Max. Bohrung Alesage max. Agujero max.	Dp	De	Df	Dm	Di	F	S	R	Peso Weight / Gewicht Poids / Peso Kg	
Acciaio / Steel / Stahl Acier / Acero	con flangia / with flanges mit Flanges / avec flasques / con tapetas	28 8M 50	4F	FL079	1210	32	71,30	69,93	75,0	-	50	60	25	17,5	0,60
		30 8M 50	5F	FL073	1615	42	76,39	75,02	83,0	-	58	60	38	22,0	0,65
		32 8M 50	5F	FL076	1615	42	81,49	80,16	87,0	-	62	60	38	22,0	0,82
		34 8M 50	5F	FL066	1615	42	86,58	85,22	91,0	-	65	60	38	22,0	1,06
		36 8M 50	5F	FL068	1615	42	91,67	90,30	97,0	-	68	60	38	22,0	1,30
		38 8M 50	5F	FL070	1615	42	96,77	95,39	102,0	-	72	60	38	22,0	1,60
		40 8M 50	4F	FL077	2012	50	101,86	100,49	106,0	-	82	60	32	14,0	1,71
		44 8M 50	4F	FL075	2012	50	112,05	110,67	120,0	-	91	60	32	14,0	1,78
		48 8M 50	4F	FL078	2012	50	122,23	120,86	128,0	-	95	60	32	14,0	2,30
		56 8M 50	4F	FL085	2517	60	142,60	141,23	150,0	-	116	60	45	7,5	3,40
		64 8M 50	4F	FL090	2517	60	162,97	161,60	168,0	-	137	60	45	7,5	5,00
		72 8M 50	9WF	FL097	2517	60	183,35	181,97	192,0	125	158	60	45	7,5	6,70
Ghisa / Cast iron Grauguss / Fonte Hierro fundido	senza flangia / without flanges ohne Flanschen / sans flasques sin tapetas	80 8M 50	4	-	3020	75	203,72	202,35	-	-	180	60	51	4,5	8,80
		90 8M 50	9W	-	3020	75	229,18	227,81	-	170	204	60	51	4,5	10,00
		112 8M 50	9W	-	3020	75	285,21	283,83	-	170	260	60	51	4,5	12,00
		144 8M 50	9A	-	3020	75	366,69	365,32	-	170	341	60	51	4,5	15,20
		168 8M 50	7A	-	3525	90	427,81	426,44	-	198	395	60	65	2,5	17,50
		192 8M 50	7A	-	3525	90	488,92	487,55	-	198	455	60	65	2,5	24,00

HTD Profile 8M-85

Caratteristiche Features Merkmale Características	Descrizione Description Beschreibung Description Descripción	Tipo Type Typ Type Tipo	Codice flangia Flange code Bordscheiben Typ Code flasque Código brida	Bussola Bush Buchse Moyeu Casquillo	Foro max. Max. Bore Max. Bohrung Alesage max. Agujero max.	Dp	De	Df	Dm	Di	F	S	R	Peso Weight / Gewicht Poids / Peso Kg	
Acciaio / Steel / Stahl Acier / Acero	con flangia / with flanges mit Flanges / avec flasques / con tapetas	34 8M 85	4F	FL066	1615	42	86,58	85,22	91,0	-	65	95	38	28,5	1,43
		36 8M 85	4F	FL068	1615	42	91,67	90,30	97,0	-	68	95	38	28,5	1,87
		38 8M 85	4F	FL070	1615	42	96,77	95,39	102,0	-	72	95	38	28,5	2,20
		40 8M 85	4F	FL077	2012	50	101,86	100,49	106,0	-	82	95	32	31,5	1,80
		44 8M 85	4F	FL075	2012	50	112,05	110,67	120,0	-	91	95	32	31,5	2,30
		48 8M 85	4F	FL078	2517	60	122,23	120,86	128,0	-	100	95	45	25,0	2,66
		56 8M 85	4F	FL085	2517	60	142,60	141,23	150,0	-	117	95	45	25,0	4,45
		64 8M 85	4F	FL090	2517	60	162,97	161,60	168,0	-	137	95	45	25,0	6,20
		72 8M 85	4F	FL097	3020	75	183,35	181,97	192,0	-	158	95	51	22,0	8,00
Ghisa / Cast iron Grauguss / Fonte Hierro fundido	senza flangia / without flanges ohne Flanschen / sans flasques sin tapetas	80 8M 85	4	-	3020	75	203,72	202,35	-	-	180	95	51	22,0	10,00
		90 8M 85	9W	-	3020	75	229,18	227,81	-	160	204	95	51	22,0	10,80
		112 8M 85	9W	-	3020	75	285,21	283,83	-	170	260	95	51	22,0	15,00
		144 8M 85	9A	-	3525	90	366,69	365,32	-	198	336	95	65	15,0	20,00
		168 8M 85	9A	-	3525	90	427,81	426,44	-	198	395	95	65	15,0	22,00
		192 8M 85	9A	-	3525	90	488,92	487,55	-	198	455	95	65	15,0	26,00

PULEGGE DENTATE CON PROFILO HTD PER BUSSOLA CONICA HTD PROFILE TIMING BELT PULLEYS FOR TAPER BUSHES

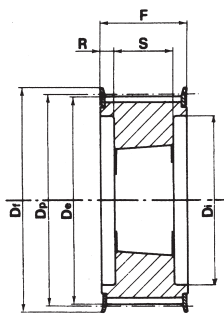

Tipo / Type
4F

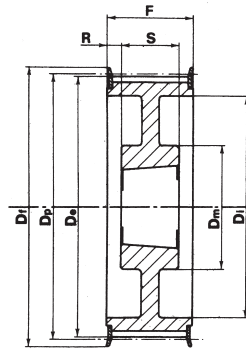

Tipo / Type
9WF

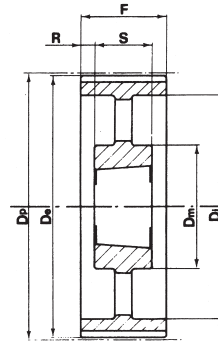

Tipo / Type
9A

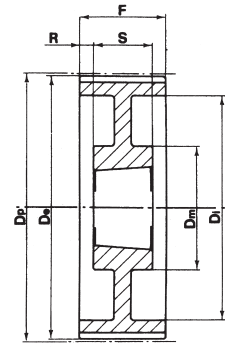

Tipo / Type
9W

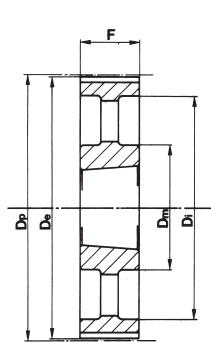

Tipo / Type
3A

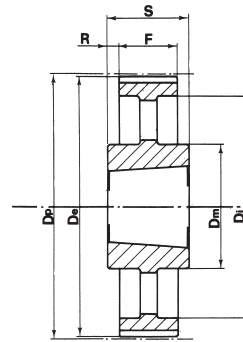

Tipo / Type
7A

HTD Profile 14M-40

Caratteristiche Features Merkmale Caracteristiques Características	Descrizione Description Beschreibung Description Descripción	Tipo Type Typ Type Tipo	Codice flangia Flange code Bordscheiben Typ Code flasque Código brida	Bussola Bush Buchse Moyeu Casquillo	Foro max. Max. Bore Max. Bohrung Alesage max. Agujero max.	Dp	De	Df	Dm	Di	F	S	R	Peso Weight / Gewicht Poids / Peso Kg	
Acciaio / Steel / Stahl Acier / Acero	con flangia / with flanges mit Flanges / avec flasques / con tapetas	28 14M 40	4F	FL153	2012	50	124,78	122,12	128,0	-	94	54	32	11,0	2,07
		29 14M 40	4F	FL154	2012	50	129,23	126,57	138,0	-	98	54	32	11,0	2,38
		30 14M 40	4F	FL154	2012	50	133,69	130,99	138,0	-	98	54	32	11,0	2,65
		32 14M 40	4F	FL160	2012	50	142,60	139,88	154,0	-	108	54	32	11,0	3,40
		34 14M 40	4F	FL166	2517	60	151,52	148,79	160,0	-	110	54	45	4,5	3,87
		36 14M 40	4F	FL168	2517	60	160,43	157,68	168,0	-	120	54	45	4,5	4,80
		38 14M 40	4F	FL172	2517	60	169,34	166,60	183,0	-	130	54	45	4,5	5,40
		40 14M 40	4F	FL162	2517	60	178,25	175,49	188,0	-	138	54	45	4,5	6,00
		44 14M 40	4F	FL175	3020	75	196,08	193,28	211,0	-	155	54	51	1,5	7,80
		48 14M 40	4F	FL180	3020	75	213,90	211,11	226,0	-	170	54	51	1,5	9,40
Ghisa / Cast iron Grauguss / Fonte Hierro fundido	senza flangia / without flanges ohne Flanschen / sans flasques sin tapetas	56 14M 40	9WF	FL182	3020	75	249,55	246,76	256,0	170	208	54	51	1,5	10,80
		64 14M 40	9WF	FL184	3020	75	285,21	282,41	296,0	170	240	54	51	1,5	13,40
		72 14M 40	9W	-	3020	75	320,86	318,06	-	170	280	54	51	1,5	15,20
		80 14M 40	9A	-	3020	75	356,51	353,71	-	170	315	54	51	1,5	16,00
		90 14M 40	9A	-	3020	75	401,07	398,28	-	170	360	54	51	1,5	17,80
		112 14M 40	9A	-	3020	75	499,11	496,32	-	170	457	54	51	1,5	25,60
		144 14M 40	9A	-	3020	75	641,71	638,92	-	170	600	54	51	1,5	32,00
		168 14M 40	9A	-	3020	75	748,66	745,87	-	170	706	54	51	1,5	44,00
		192 14M 40	9A	-	3535	90	855,62	852,82	-	190	813	54	51	1,5	49,00
		216 14M 40	9A	-	3535	90	962,57	959,76	-	190	920	54	51	1,5	55,00

PULEGGE DENTATE CON PROFILO HTD PER BUSSOLA CONICA HTD PROFILE TIMING BELT PULLEYS FOR TAPER BUSHES

HTD Profile 14M-55

Caratteristiche Features Merkmale Características	Descrizione Description Beschreibung Description Descripción	Tipo Type Typ Type Tipo	Codice flangia Flange code Bordscheiben Typ Code flasque Código brida	Bussola Bush Buchse Moyeu Casquillo	Foro max. Max. Bore Max. Bohrung Alesage max. Agujero max.	Dp	De	Df	Dm	Di	F	S	R	Peso Weight / Gewicht Poids / Peso Kg	
Acciaio / Steel / Stahl Acier / Acero	con flangia / with flanges mit Flanges / avec flasques / con tapetas	28 14M 55	4F	FL153	2012	50	124,78	122,12	128,0	-	94	70	32	19,0	2,20
		29 14M 55	4F	FL154	2012	50	129,23	126,57	138,0	-	100	70	32	19,0	2,74
		30 14M 55	4F	FL154	2517	60	133,69	130,99	138,0	-	100	70	45	12,5	2,70
		32 14M 55	4F	FL160	2517	60	142,60	139,88	154,0	-	108	70	45	12,5	3,66
		34 14M 55	4F	FL166	2517	60	151,52	148,79	160,0	-	110	70	45	12,5	4,55
		36 14M 55	4F	FL168	2517	60	160,43	157,68	168,0	-	120	70	45	12,5	5,20
		38 14M 55	4F	FL172	2517	60	169,34	166,60	183,0	-	130	70	45	12,5	6,20
		40 14M 55	4F	FL162	2517	60	178,25	175,49	188,0	-	138	70	45	12,5	7,00
		44 14M 55	4F	FL175	3020	75	196,08	193,28	211,0	-	155	70	51	9,5	8,60
		48 14M 55	4F	FL180	3020	75	213,90	211,11	226,0	-	170	70	51	9,5	10,40
		56 14M 55	9WF	FL182	3020	75	249,55	246,76	256,0	170	208	70	51	9,5	12,40
		64 14M 55	9WF	FL184	3020	75	285,21	282,41	296,0	170	240	70	51	9,5	14,50
Ghisa / Cast iron / Grauguss Fonte / Hierro fundido	senza flangia / without flanges ohne Flanschen / sans flasques sin tapetas	72 14M 55	9W	-	3020	75	320,86	318,06	-	170	280	70	51	9,5	16,20
		80 14M 55	9A	-	3020	75	356,51	353,71	-	170	315	70	51	9,5	17,50
		90 14M 55	9A	-	3020	75	401,07	398,28	-	170	360	70	51	9,5	20,10
		112 14M 55	9A	-	3020	75	499,11	496,32	-	170	457	70	51	9,5	28,40
		144 14M 55	9A	-	3020	75	641,71	638,92	-	170	600	70	51	9,5	36,20
		168 14M 55	9A	-	3020	75	748,66	745,87	-	170	706	70	51	9,5	49,00
		192 14M 55	9A	-	3535	90	855,62	852,82	-	170	813	70	51	9,5	53,00
		216 14M 55	7A	-	3535	90	962,57	959,76	-	190	920	70	89	9,5	65,80

HTD Profile 14M 85

Caratteristiche Features Merkmale Características	Descrizione Description Beschreibung Description Descripción	Tipo Type Typ Type Tipo	Codice flangia Flange code Bordscheiben Typ Code flasque Código brida	Bussola Bush Buchse Moyeu Casquillo	Foro max. Max. Bore Max. Bohrung Alesage max. Agujero max.	Dp	De	Df	Dm	Di	F	S	R	Peso Weight / Gewicht Poids / Peso Kg	
Acciaio / Steel / Stahl Acier / Acero	con flangia / with flanges mit Flanges / avec flasques / con tapetas	28 14M 85	4F	FL153	2517	60	124,78	122,12	128,0	-	98	102	45	28,5	2,70
		29 14M 85	4F	FL154	2517	60	129,23	126,57	138,0	-	100	102	45	28,5	3,40
		30 14M 85	4F	FL154	2517	60	133,69	130,99	138,0	-	100	102	45	28,5	3,75
		32 14M 85	4F	FL160	2517	60	142,60	139,88	154,0	-	108	102	45	28,5	4,80
		34 14M 85	4F	FL166	2517	60	151,52	148,79	160,0	-	110	102	45	28,5	6,00
		36 14M 85	4F	FL168	3020	75	160,43	157,68	168,0	-	120	102	51	25,5	5,80
		38 14M 85	4F	FL172	3020	75	169,34	166,60	183,0	-	130	102	51	25,5	6,80
		40 14M 85	4F	FL162	3020	75	178,25	175,49	188,0	-	138	102	51	25,5	8,00
		44 14M 85	4F	FL175	3020	75	196,08	193,28	211,0	-	153	102	51	25,5	11,80
		48 14M 85	4F	FL180	3020	75	213,90	211,11	226,0	-	170	102	51	25,5	15,10
		56 14M 85	4F	FL182	3525	90	249,55	246,76	256,0	-	210	102	65	18,5	19,00
		64 14M 85	9WF	FL184	3525	90	285,21	282,41	296,0	190	240	102	65	18,5	23,00
Ghisa / Cast iron / Grauguss Fonte / Hierro fundido	senza flangia / without flanges ohne Flanschen / sans flasques sin tapetas	72 14M 85	9W	-	3525	90	320,86	318,06	-	190	280	102	65	18,5	25,00
		80 14M 85	9A	-	3525	90	356,51	353,71	-	190	315	102	65	18,5	26,00
		90 14M 85	9A	-	3525	90	401,07	398,28	-	190	360	102	65	18,5	27,80
		112 14M 85	9A	-	3525	90	499,11	496,32	-	190	457	102	65	18,5	36,50
		144 14M 85	9A	-	3525	90	641,71	638,92	-	190	600	102	65	18,5	48,00
		168 14M 85	9A	-	3525	90	748,66	745,87	-	190	706	102	65	18,5	60,00
		192 14M 85	3A	-	4040	100	855,62	852,82	-	190	813	102	102	-	86,00
		216 14M 85	3A	-	4040	100	962,57	959,76	-	190	920	102	102	-	91,50

PULEGGE DENTATE CON PROFILO HTD PER BUSSOLA CONICA HTD PROFILE TIMING BELT PULLEYS FOR TAPER BUSHES

HTD Profile 14M-115

Caratteristiche Features Merkmale Características	Descrizione Description Beschreibung Description Descripción	Tipo Type Typ Type Tipo	Codice flangia Flange code Bordscheiben Typ Code flasque Código brida	Bussola Bush Buchse Moyeu Casquillo	Foro max. Max. Bore Max. Bohrung Alesage max. Agujero max.	Dp	De	Df	Dm	Di	F	S	R	Peso Weight / Gewicht Poids / Peso Kg	
Acciaio / Steel / Stahl Acier / Acero	con flangia / with flanges mit Flanges / avec flasques / con tapetas	28-14M-115	4F	FL153	2517	60	124,78	122,12	128,0	-	98	133	45	44,0	3,77
		29-14M-115	4F	FL154	2517	60	129,23	126,57	138,0	-	100	133	45	44,0	4,00
		30-14M-115	4F	FL154	2517	60	133,69	130,99	138,0	-	100	133	45	44,0	5,00
		32-14M-115	4F	FL160	2517	60	142,60	139,88	154,0	-	108	133	45	44,0	6,80
		34-14M-115	4F	FL166	2517	60	151,52	148,79	160,0	-	110	133	45	44,0	6,80
		36-14M-115	4F	FL168	3020	75	160,43	157,68	168,0	-	125	133	51	41,0	7,00
		38-14M-115	4F	FL172	3020	75	169,34	166,60	183,0	-	130	133	51	41,0	8,40
		40-14M-115	4F	FL162	3020	75	178,25	175,49	188,0	-	138	133	51	41,0	9,20
		44-14M-115	4F	FL175	3030	75	196,08	193,28	211,0	-	155	133	76	28,5	14,00
		48-14M-115	4F	FL180	3030	75	213,90	211,11	226,0	-	170	133	76	28,5	17,10
		56-14M-115	4F	FL182	3535	90	249,55	246,76	256,0	-	208	133	89	22,0	24,80
		64-14M-115	9WF	FL184	3535	90	285,21	282,41	296,0	190	240	133	89	22,0	27,00
Ghisa / Cast iron / Grauguss Fonte / Hierro fundido	senza flangia / without flanges ohne Flanschen / sans flasques sin tapetas	72-14M-115	9W	-	3535	90	320,86	318,06	-	190	280	133	89	22,0	29,00
		80-14M-115	9A	-	3535	90	356,51	353,71	-	190	315	133	89	22,0	32,00
		90-14M-115	9A	-	3535	90	401,07	398,28	-	190	360	133	89	22,0	36,50
		112-14M-115	9A	-	3535	90	499,11	496,32	-	190	457	133	89	22,0	46,00
		144-14M-115	9A	-	4040	100	641,71	638,92	-	230	600	133	102	15,5	68,00
		168-14M-115	9A	-	4040	100	748,66	745,87	-	230	706	133	102	15,5	82,60
		192-14M-115	9A	-	4040	100	855,62	852,82	-	230	813	133	102	15,5	96,00
		216-14M-115	9A	-	4040	100	962,57	959,76	-	230	920	133	102	15,5	107,00

HTD Profile 14M-170

Caratteristiche Features Merkmale Características	Descrizione Description Beschreibung Description Descripción	Tipo Type Typ Type Tipo	Codice flangia Flange code Bordscheiben Typ Code flasque Código brida	Bussola Bush Buchse Moyeu Casquillo	Foro max. Max. Bore Max. Bohrung Alesage max. Agujero max.	Dp	De	Df	Dm	Di	F	S	R	Peso Weight / Gewicht Poids / Peso Kg	
Acciaio / Steel / Stahl Acier / Acero	con flangia / with flanges mit Flanges / avec flasques con tapetas	38-14M-170	4F	FL172	3030	75	169,34	166,60	183,0	-	130	187	76	55,5	11,70
		40-14M-170	4F	FL162	3030	75	178,25	175,49	188,0	-	138	187	76	55,5	13,00
		44-14M-170	4F	FL175	3535	90	196,08	193,28	211,0	-	153	187	89	49,0	15,00
		48-14M-170	4F	FL180	3535	90	213,90	211,11	226,0	-	170	187	89	49,0	19,00
		56-14M-170	4F	FL182	3535	90	249,55	246,76	256,0	-	208	187	89	49,0	28,50
		64-14M-170	4F	FL184	4040	100	285,21	282,41	296,0	-	240	187	102	42,5	41,00
Ghisa / Cast iron / Grauguss Fonte / Hierro fundido	senza flangia / without flanges ohne Flanschen / sans flasques sin tapetas	72-14M-170	9W	-	4040	100	320,86	318,06	-	230	280	187	102	42,5	46,90
		80-14M-170	9W	-	4040	100	356,51	353,71	-	230	315	187	102	42,5	48,00
		90-14M-170	9A	-	4040	100	401,07	398,28	-	230	360	187	102	42,5	52,50
		112-14M-170	9A	-	5050	125	499,11	496,32	-	265	457	187	127	30,0	74,50
		144-14M-170	9A	-	5050	125	641,71	638,92	-	265	600	187	127	30,0	91,00
		168-14M-170	9A	-	5050	125	748,66	745,87	-	265	706	187	127	30,0	116,00
		192-14M-170	9A	-	5050	125	855,62	852,82	-	265	813	187	127	30,0	134,00
		216-14M-170	9A	-	5050	125	962,57	959,76	-	265	920	187	127	30,0	146,50

PULEGGE DENTATE PER CINGHIE GW TIMING BELT PULLEYS GW



PULEGGE DENTATE PER CINGHIE GW TIMING BELT PULLEYS GW

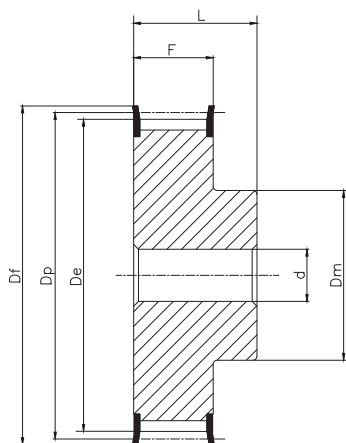

**Tipo / Type
6F**

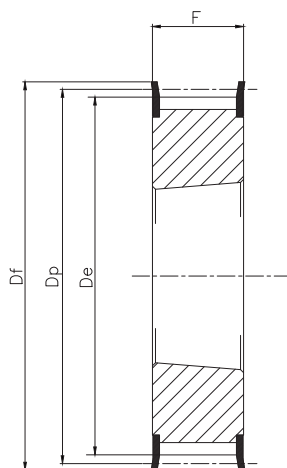

**Tipo / Type
3F**

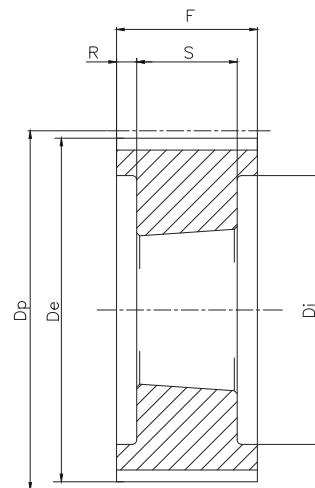

**Tipo / Type
4**

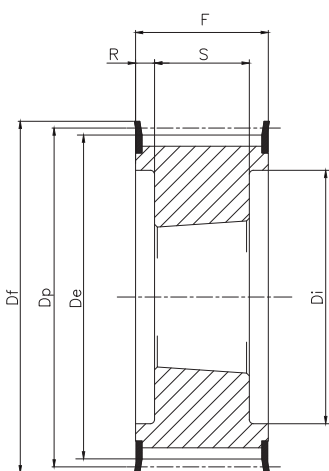

**Tipo / Type
4F**

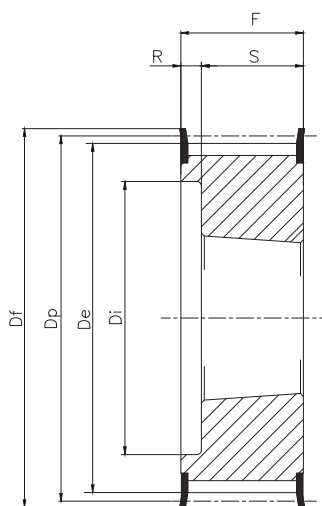

**Tipo / Type
5F2**

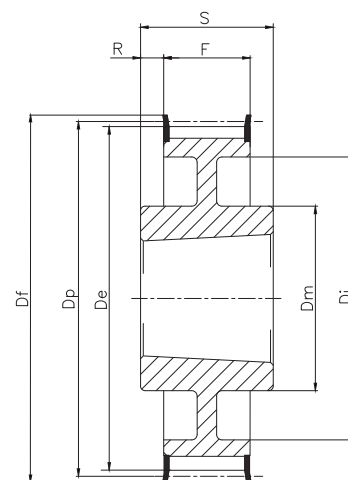

**Tipo / Type
7WF**

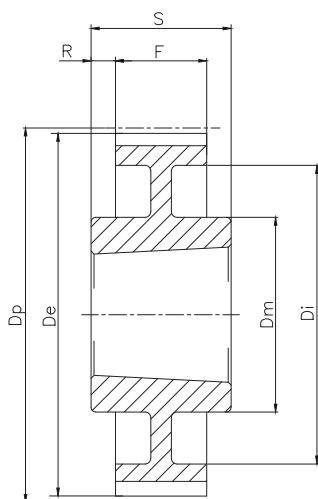

**Tipo / Type
7W**

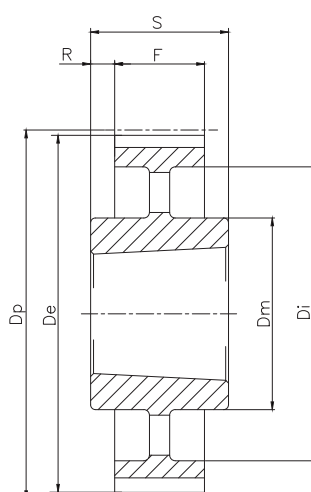

**Tipo / Type
7A**

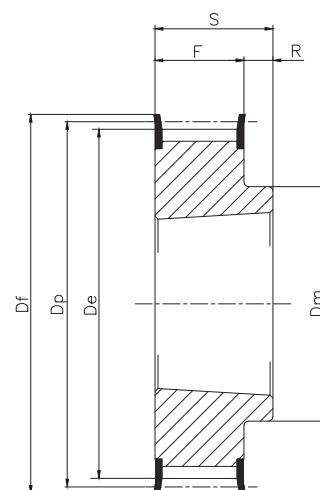

**Tipo / Type
8F**

PULEGGE DENTATE PER CINGHIE GW TIMING BELT PULLEYS GW

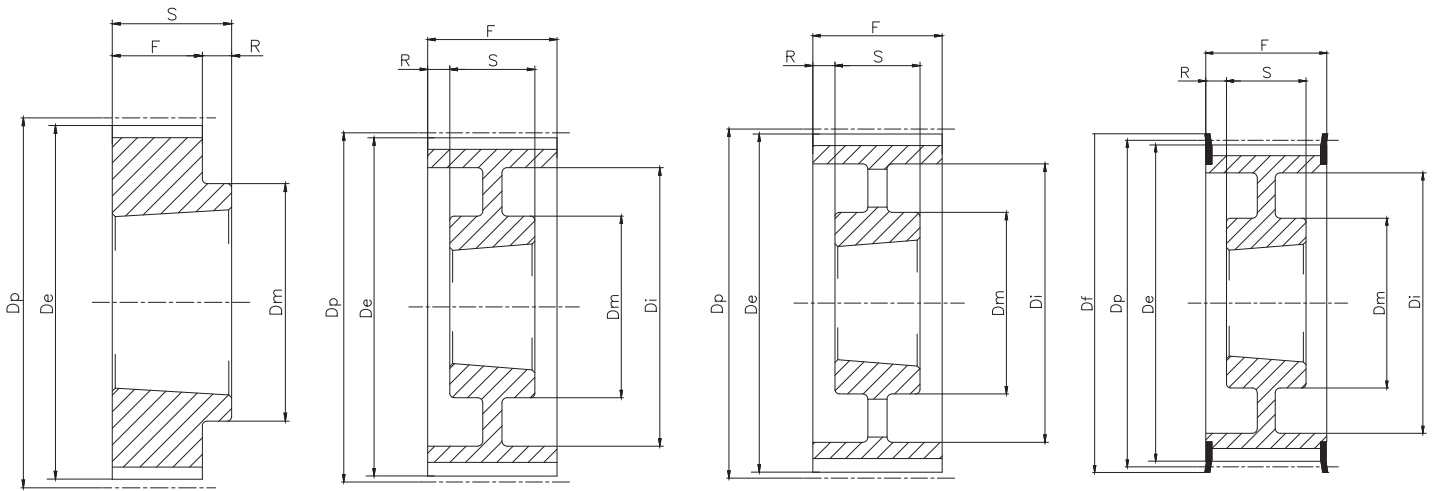

**Tipo / Type
8**

**Tipo / Type
9W**

**Tipo / Type
9A**

**Tipo / Type
9WF**

PC8M-12

Caratteristiche Features Merkmale Caracteristiques Características	Descrizione Description Beschreibung Description Descripción	Tipo Type Typ Type Tipo	Codice flangia Flange code Bordscheiben- Code Code flasque Código brida	N. denti N. of teeth Zähnezahl N. bre de dents Cantidad de dientes	Foro d / Bussola. Bush d / Bore. Bohrung d / Buchse. Alesage d / Moyeu. Agujero d / Casquillo.	Dp	De	Df	Dm	Di	F	S	R	Peso Weight Gewicht Poids Peso Kg	
Acciaio / Steel / Stahl Acier / Acero	con flangia / with flanges mit Flanges / avec flasques / con tapetas	PC8M-22S-12	6F	FL053	22	12	56,02	54,42	60,0	43	-	20	30	10,0	0,54
	TL PC8M-25S-12	8F	FL061	25	1108	63,66	62,06	70,0	49	-	20	22	2,0	0,49	
	TL PC8M-28S-12	8F	FL079	28	1108	71,30	69,70	75,0	56	-	20	22	2,0	0,66	
	TL PC8M-30S-12	8F	FL073	30	1210	76,39	74,79	83,0	60	-	20	25	5,0	0,83	
	TL PC8M-32S-12	8F	FL076	32	1610	81,49	79,89	87,0	66	-	20	25	5,0	0,93	
	TL PC8M-34S-12	8F	FL066	34	1610	86,58	84,98	91,0	68	-	20	25	5,0	1,05	
	TL PC8M-36S-12	8F	FL068	36	1610	91,67	90,07	97,0	74	-	20	25	5,0	1,17	
	TL PC8M-38S-12	8F	FL070	38	1610	96,77	95,17	102,0	80	-	20	25	5,0	1,29	
	TL PC8M-40S-12	8F	FL077	40	1610	101,86	100,26	106,0	85	-	20	25	5,0	1,43	
	TL PC8M-45S-12	8F	FL075	45	2012	114,59	112,99	120,0	92	-	20	32	12,0	2,30	
	TL PC8M-48S-12	8F	FL078	48	2012	122,23	120,63	128,0	100	-	20	32	12,0	2,49	
	TL PC8M-50S-12	8F	FL080	50	2012	127,32	125,72	135,0	104	-	20	32	12,0	2,70	
	TL PC8M-56S-12	8F	FL085	56	2012	142,60	141,00	150,0	104	-	20	32	12,0	3,88	
TL PC8M-60S-12	8F	FL086	60	2012	152,79	151,19	158,0	111	-	20	32	12,0	4,42		
TL PC8M-64S-12	8F	FL090	64	2012	162,97	161,37	168,0	111	-	20	32	12,0	4,99		
Ghisa / Cast iron Grauguss / Fonte Hierro fundido	senza flangia / without flanges ohne Flanschen / sans flasques sin tapetas	TL PC8M-75S-12	8	-	74	2012	190,99	189,39	-	111	-	20	32	12,0	6,90
	TL PC8M-80S-12	8	-	80	2012	203,72	202,12	-	111	-	20	32	12,0	7,75	
	TL PC8M-90S-12	8	-	90	2012	229,18	227,58	-	111	-	20	32	12,0	9,94	

PULEGGE DENTATE PER CINGHIE GW TIMING BELT PULLEYS GW

PC8M-21

Caratteristiche Features Merkmale Características	Descrizione Description Beschreibung Description Descripción	Tipo Type Typ Type Tipo	Codice flangia Flange code Bordscheiben- Code Code flasque Código brida	N. denti N. of teeth / Zähnezahl N. bre de dents Cantidad de dientes	Foro d / Bussola. Bush d / Bore. Bohrung d / Buchse. Alesage d / Moyeu. Agujero d / Casquillo.	Dp	De	Df	Dm	Di	F	S	R	Peso Weight Gewicht Poids Peso Kg	
Acciaio / Steel / Stahl Acier / Acero	con flangia / with flanges mit Flanges / avec flasques / con tapetas	PC8M-22S-21	6F	FL053	22	12	56,02	54,42	60,0	43	-	30	40	10,0	0,73
		TL PC8M-25S-21	3F	FL061	25	1108	63,66	62,06	70,0	-	-	30	-	-	0,49
		TL PC8M-28S-21	3F	FL079	28	1210	71,30	69,70	75,0	-	-	30	-	-	0,85
		TL PC8M-30S-21	3F	FL073	30	1210	76,39	74,79	83,0	-	-	30	-	-	0,97
		TL PC8M-32S-21	3F	FL076	32	1610	81,49	79,89	87,0	-	-	30	-	-	1,09
		TL PC8M-34S-21	3F	FL066	34	1610	86,58	84,98	91,0	-	-	30	-	-	1,22
		TL PC8M-36S-21	3F	FL068	36	1610	91,67	90,07	97,0	-	-	30	-	-	1,36
		TL PC8M-38S-21	3F	FL070	38	1610	96,77	95,17	102,0	-	-	30	-	-	1,51
		TL PC8M-40S-21	3F	FL077	40	1610	101,86	100,26	106,0	-	-	30	-	-	1,66
		TL PC8M-45S-21	8F	FL075	45	2012	114,59	112,99	120,0	92	-	30	32	2,0	2,30
		TL PC8M-48S-21	8F	FL078	48	2012	122,23	120,63	128,0	100	-	30	32	2,0	2,49
		TL PC8M-50S-21	8F	FL080	50	2012	127,32	125,72	135,0	104	-	30	32	2,0	2,70
		TL PC8M-56S-21	8F	FL085	56	2012	142,60	141,00	150,0	111	-	30	32	2,0	3,88
		TL PC8M-60S-21	8F	FL086	60	2517	152,79	151,19	158,0	124	-	30	45	15,0	5,85
TL PC8M-64S-21	8F	FL090	64	2517	162,97	161,37	168,0	124	-	30	45	15,0	6,61		
Ghisa / Cast iron Grauguss / Fonte Hierro fundido	senza flangia / without flanges ohne Flanschen / sans flasques sin tapetas	TL PC8M-75S-21	8	-	75	2517	190,99	189,39	-	124	-	30	45	15,0	7,84
		TL PC8M-80S-21	8	-	80	2517	203,72	202,12	-	124	-	30	45	15,0	9,45
		TL PC8M-90S-21	7W	-	90	2517	229,18	227,58	-	124	198	30	45	7,5	11,55
		TL PC8M-112S-21	7W	-	112	2517	285,21	283,61	-	124	253	30	45	7,5	17,15
		TL PC8M-140S-21	7A	-	140	3020	356,51	354,91	-	150	324	30	51	10,5	33,25

PC8M-36

Caratteristiche Features Merkmale Características	Descrizione Description Beschreibung Description Descripción	Tipo Type Typ Type Tipo	Codice flangia Flange code Bordscheiben- Code Code flasque Código brida	N. denti N. of teeth / Zähnezahl N. bre de dents Cantidad de dientes	Foro d / Bussola. Bush d / Bore. Bohrung d / Buchse. Alesage d / Moyeu. Agujero d / Casquillo.	Dp	De	Df	Dm	Di	F	S	R	Peso Weight Gewicht Poids Peso Kg	
Acciaio / Steel / Stahl Acier / Acero	con flangia / with flanges mit Flanges / avec flasques / con tapetas	PC8M-25S-36	6F	FL061	25	12	63,66	62,06	70,0	49	-	45	55	10,0	1,09
		TL PC8M-28S-36	3F	FL079	28	1210	71,30	69,70	75,0	-	-	45	-	-	1,21
		TL PC8M-30S-36	3F	FL073	30	1610	76,39	74,79	83,0	-	-	45	-	-	1,38
		TL PC8M-32S-36	3F	FL076	32	1610	81,89	79,89	87,0	-	-	45	-	-	1,56
		TL PC8M-34S-36	3F	FL066	34	1610	86,58	84,98	91,0	-	-	45	-	-	1,75
		TL PC8M-36S-36	3F	FL068	36	1610	91,67	90,07	97,0	-	-	45	-	-	1,95
		TL PC8M-38S-36	3F	FL070	38	1610	96,77	95,17	102,0	-	-	45	-	-	2,16
		TL PC8M-40S-36	3F	FL077	40	2012	101,86	100,26	106,0	-	-	45	-	-	2,38
		TL PC8M-45S-36	3F	FL075	45	2012	114,59	112,99	120,0	-	-	45	-	-	3,11
		TL PC8M-48S-36	3F	FL078	48	2012	122,23	120,63	128,0	-	-	45	-	-	3,37
		TL PC8M-50S-36	3F	FL080	50	2012	127,32	125,72	135,0	-	-	45	-	-	3,64
		TL PC8M-56S-36	3F	FL085	56	2517	142,60	141,00	150,0	-	-	45	-	-	5,14
		TL PC8M-60S-36	3F	FL086	60	2517	152,79	151,19	158,0	-	-	45	-	-	5,85
TL PC8M-64S-36	3F	FL090	64	2517	162,97	161,37	168,0	-	-	45	-	-	6,61		
Ghisa / Cast iron Grauguss / Fonte Hierro fundido	senza flangia / without flanges ohne Flanschen / sans flasques sin tapetas	TL PC8M-75S-36	8	-	75	3020	190,99	189,39	-	150	-	45	51	6,0	9,47
		TL PC8M-80S-36	8	-	80	3020	203,72	202,12	-	150	-	45	51	6,0	10,64
		TL PC8M-90S-36	7W	-	90	3020	229,18	227,58	-	150	197	45	51	3,0	13,64
		TL PC8M-112S-36	7W	-	112	3020	285,21	283,61	-	150	253	45	51	3,0	18,21
		TL PC8M-140S-36	7A	-	140	3020	356,51	354,91	-	150	324	45	51	3,0	24,92
		TL PC8M-168S-36	7A	-	168	3525	427,81	426,21	-	198	396	45	65	10,0	31,92
		TL PC8M-192S-36	7A	-	192	3525	488,92	487,32	-	198	457	45	65	10,0	45,92

PULEGGE DENTATE PER CINGHIE GW TIMING BELT PULLEYS GW

PC8M-62

Caratteristiche Features Merkmale Características	Descrizione Description Beschreibung Description Descripción	Tipo Type Typ Type Tipo	Codice flangia Flange code Bordscheiben- Code Code flasque Código brida	N. denti N. of teeth / Zähnezahl N. bre de dents Cantidad de dientes	Foro d / Bussola. Bush d / Bore. Bohrung d / Buchse. Alesage d / Moyeu. Agujero d / Casquillo.	Dp	De	Df	Dm	Di	F	S	R	Peso Weight Gewicht Poids Peso Kg	
Acciaio / Steel / Stahl Acier / Acero	con flangia / with flanges mit Flanges / avec flasques / con tapetas	PC8M-30S-62	6F	FL073	30	15	76,39	74,79	83,0	62	-	72	84	12,0	2,46
		PC8M-32S-62	6F	FL076	32	15	81,49	79,89	87,0	65	-	72	84	12,0	2,77
		PC8M-34S-62	6F	FL066	34	15	86,58	84,98	91,0	70	-	72	84	12,0	3,11
		PC8M-36S-62	6F	FL068	36	15	91,67	90,07	97,0	75	-	72	84	12,0	3,46
		PC8M-38S-62	6F	FL070	38	15	96,77	95,17	102,0	75	-	72	84	12,0	3,84
		TL PC8M-40S-62	3F	FL077	40	2012	101,86	100,26	106,0	-	-	72	-	-	3,66
		TL PC8M-45S-62	3F	FL075	45	2012	114,59	112,99	120,0	-	-	72	-	-	4,78
		TL PC8M-48S-62	3F	FL078	48	2517	122,23	120,63	128,0	-	-	72	-	-	5,19
		TL PC8M-50S-62	3F	FL080	50	2517	127,32	125,72	135,0	-	-	72	-	-	5,61
		TL PC8M-56S-62	9WF	FL085	56	2517	142,60	141,00	150,0	-	111	72	45	13,5	7,76
		TL PC8M-60S-62	9WF	FL086	60	2517	152,79	151,19	158,0	-	121	72	45	13,5	8,83
		TL PC8M-64S-62	9WF	FL090	64	2517	162,97	161,37	168,0	-	131	72	45	13,5	9,97
Ghisa / Cast Iron Grauguss / Fonte Hierro fundido	senza flangia / without flanges ohne Flanschen / sans flasques sin tapetas	TL PC8M-75S-62	4	-	75	3020	190,99	189,39	-	-	159	72	51	10,5	10,92
		TL PC8M-80S-62	4	-	80	3020	203,72	202,12	-	-	172	72	51	10,5	13,16
		TL PC8M-90S-62	4	-	90	3020	229,18	227,58	-	-	197	72	51	10,5	16,59
		TL PC8M-112S-62	9W	-	112	3020	285,21	283,61	-	150	253	72	51	10,5	22,05
		TL PC8M-140S-62	9W	-	140	3525	356,51	354,91	-	198	324	72	65	3,5	30,17
		TL PC8M-168S-62	9A	-	168	3525	427,81	426,21	-	198	396	72	65	3,5	39,34
		TL PC8M-192S-62	9A	-	192	3525	488,92	487,32	-	198	457	72	65	3,5	56,21

PC14M-20

Caratteristiche Features Merkmale Características	Descrizione Description Beschreibung Description Descripción	Tipo Type Typ Type Tipo	Codice flangia Flange code Bordscheiben- Code Code flasque Código brida	N. denti N. of teeth / Zähnezahl N. bre de dents Cantidad de dientes	Foro d / Bussola. Bush d / Bore. Bohrung d / Buchse. Alesage d / Moyeu. Agujero d / Casquillo.	Dp	De	Df	Dm	Di	F	S	R	Peso Weight Gewicht Poids Peso Kg	
Acciaio / Steel / Stahl Acier / Acero	con flangia / with flanges mit Flanges / avec flasques / con tapetas	TL 28-PC14M-20	3F	FL153	28	2012	124,78	121,98	128,0	-	-	33	-	-	2,52
		TL 30-PC14M-20	3F	FL154	30	2012	133,69	130,89	138,0	-	-	33	-	-	2,98
		TL 32-PC14M-20	3F	FL160	32	2012	142,6	139,8	154,0	-	-	33	-	-	3,47
		TL 34-PC14M-20	8F	FL171	34	2517	151,52	148,72	160,0	117	-	33	45	12,0	4,34
		TL 36-PC14M-20	8F	FL168	36	2517	160,43	157,53	168,0	117	-	33	45	12,0	4,89
		TL 38-PC14M-20	8F	FL172	38	2517	169,34	166,54	183,0	117	-	33	45	12,0	5,48
		TL 40-PC14M-20	8F	FL174	40	2517	178,25	175,45	188,0	117	-	33	45	12,0	6,10
		TL 44-PC14M-20	8F	FL175	44	3020	196,08	193,28	211,0	144	-	33	51	18,0	7,89
		TL 48-PC14M-20	8F	FL180	48	3020	213,9	211,11	226,0	144	-	33	51	18,0	9,35
		TL 50-PC14M-20	8F	FL169	50	3020	222,82	220,02	240,0	144	-	33	51	18,0	9,49
Ghisa / Cast Iron Grauguss / Fonte Hierro fundido	senza flangia / without flanges ohne Flanschen / sans flasques sin tapetas	TL 56-PC14M-20	7WF	FL182	56	3020	249,55	246,76	256,0	144	207	33	51	9,0	10,67
		TL 60-PC14M-20	7W	-	60	3020	267,38	264,58	-	159	224	33	51	9,0	12,66
		TL 64-PC14M-20	7W	-	64	3020	285,21	282,41	-	159	242	33	51	9,0	13,88
		TL 72-PC14M-20	7W	-	72	3020	320,86	318,06	-	159	278	33	51	9,0	16,53
		TL 80-PC14M-20	7W	-	80	3020	356,51	353,71	-	159	314	33	51	9,0	19,47
		TL 90-PC14M-20	7A	-	90	3020	401,07	398,27	-	159	360	33	51	9,0	23,49
		TL 112-PC14M-20	7A	-	112	3020	499,11	496,31	-	159	456	33	51	9,0	34,22
TL 140-PC14M-20	7A	-	140	3020	623,89	621,09	-	159	581	33	51	9,0	43,26		

PULEGGE DENTATE PER CINGHIE GW TIMING BELT PULLEYS GW

PC14M-37

Caratteristiche Features Merkmale Características Características	Descrizione Description Beschreibung Description Descripción	Tipo Type Typ Type Tipo	Codice flangia Flange code Bordscheiben- Code Code flasque Código brida	N. denti N. of teeth / Zähnezahl N. bre de dents Cantidad de dientes	Foro d / Bussola. Bush d / Bore. Bohrung d / Buchse. Alesage d / Moyeu. Agujero d / Casquillo.	Dp	De	Df	Dm	Di	F	S	R	Peso Weight Gewicht Poids Peso Kg	
Acciaio / Steel / Stahl Acier / Acero	con flangia / with flanges mit Flanges / avec flasques / con tapetas	TL 28-PC14M-37	5F2	FL153	28	2012	124,78	121,98	128,0	-	88	51	32	19,0	3,70
		TL 30-PC14M-37	4F	FL154	30	2517	133,69	130,89	138,0	-	98	51	45	3,0	3,86
		TL 32-PC14M-37	4F	FL160	32	2517	142,6	139,8	154,0	-	100	51	45	3,0	4,60
		TL 34-PC14M-37	4F	FL171	34	2517	151,52	148,72	160,0	-	109	51	45	3,0	5,34
		TL 36-PC14M-37	5F2	FL168	36	2517	160,43	157,53	168,0	-	117	51	45	6,0	6,12
		TL 38-PC14M-37	5F2	FL172	38	2517	169,34	166,54	183,0	-	126	51	45	6,0	6,96
		TL 40-PC14M-37	5F2	FL174	40	2517	178,25	175,45	188,0	-	135	51	45	6,0	7,83
		TL 44-PC14M-37	3F	FL175	44	3020	196,08	193,28	211,0	-	-	51	-	-	9,73
		TL 48-PC14M-37	3F	FL180	48	3020	213,9	211,11	226,0	-	-	51	-	-	12,00
		TL 50-PC14M-37	3F	FL169	50	3020	222,82	220,02	240,0	-	-	51	-	-	12,36
Ghisa / Cast Iron Grauguss / Fonte Hierro fundido	senza flangia / without flanges ohne Flanschen / sans flasques sin tapetas	TL 56-PC14M-37	9WF	FL182	56	3020	249,55	246,76	256,0	144	207	51	51	-	14,18
		TL 60-PC14M-37	9W	-	60	3020	267,38	264,58	-	159	224	51	51	-	16,54
		TL 64-PC14M-37	9W	-	64	3020	285,21	282,41	-	159	242	51	51	-	18,42
		TL 72-PC14M-37	9W	-	72	3020	320,86	318,06	-	159	278	51	51	-	22,52
		TL 80-PC14M-37	9W	-	80	3020	356,51	353,71	-	159	314	51	51	-	27,06
		TL 90-PC14M-37	9A	-	90	3020	401,07	398,27	-	159	360	51	51	-	33,27
		TL 112-PC14M-37	9A	-	112	3020	499,11	496,31	-	159	456	51	51	-	49,85
		TL 140-PC14M-37	7A	-	140	3525	623,89	621,09	-	206	581	51	65	7,0	79,63
		TL 168-PC14M-37	7A	-	168	3525	748,66	745,87	-	206	706	51	65	7,0	94,25
		TL 192-PC14M-37	7A	-	192	4030	855,61	852,82	-	215	812	51	76	12,5	122,63

PC14M-68

Caratteristiche Features Merkmale Características Características	Descrizione Description Beschreibung Description Descripción	Tipo Type Typ Type Tipo	Codice flangia Flange code Bordscheiben- Code Code flasque Código brida	N. denti N. of teeth / Zähnezahl N. bre de dents Cantidad de dientes	Foro d / Bussola. Bush d / Bore. Bohrung d / Buchse. Alesage d / Moyeu. Agujero d / Casquillo.	Dp	De	Df	Dm	Di	F	S	R	Peso Weight Gewicht Poids Peso Kg	
Acciaio / Steel / Stahl Acier / Acero	con flangia / with flanges mit Flanges / avec flasques / con tapetas	34-PC14M-68	6F	FL171	34	32	151,52	148,72	160,0	131	-	84	104	20,0	13,01
		36-PC14M-68	6F	FL168	36	32	160,43	157,53	168,0	131	-	84	104	20,0	14,40
		38-PC14M-68	6F	FL172	38	32	169,34	166,54	183,0	141	-	84	104	20,0	16,15
		40-PC14M-68	6F	FL174	40	32	178,25	175,45	188,0	155	-	84	104	20,0	18,28
		TL 44-PC14M-68	4F	FL175	44	3020	196,08	193,28	211,0	-	153	84	51	16,5	14,03
		TL 48-PC14M-68	5F2	FL180	48	3020	213,9	211,11	226,0	-	171	84	51	33,0	15,11
		TL 50-PC14M-68	4F	FL169	50	3525	222,82	220,02	240,0	-	180	84	65	9,5	16,16
		TL 56-PC14M-68	4F	FL182	56	3525	249,55	246,76	256,0	-	207	84	65	9,5	21,06
Ghisa / Cast Iron Grauguss / Fonte Hierro fundido	senza flangia / without flanges ohne Flanschen / sans flasques sin tapetas	TL 60-PC14M-68	4	-	60	3525	267,38	264,58	-	-	224	84	65	9,5	24,68
		TL 64-PC14M-68	4	-	64	3525	285,21	282,41	-	-	242	84	65	9,5	28,48
		TL 72-PC14M-68	9W	-	72	3525	320,86	318,06	-	178	278	84	65	9,5	37,28
		TL 80-PC14M-68	9W	-	80	3525	356,51	353,71	-	178	314	84	65	9,5	44,76
		TL 90-PC14M-68	9A	-	90	3525	401,07	398,27	-	178	360	84	65	9,5	54,99
		TL 112-PC14M-68	9A	-	112	3525	499,11	496,31	-	178	456	84	65	9,5	82,31
		TL 140-PC14M-68	9A	-	140	3525	623,89	621,09	-	206	581	84	65	9,5	107,81
		TL 168-PC14M-68	9A	-	168	3525	748,66	745,87	-	206	706	84	65	9,5	151,57
TL 192-PC14M-68	9A	-	192	4030	855,61	852,82	-	215	812	84	76	4,0	195,32		

PULEGGE DENTATE PER CINGHIE GW TIMING BELT PULLEYS GW

PC14M-90

Caratteristiche Features Merkmale Características		Descrizione Description Beschreibung Description Descripción	Tipo Type Typ Type Tipo	Codice flangia Flange code Bordscheiben- Code Code flasque Código brida	Foro d / Bussola. Bush d / Bore. Bohrung d / Buchse. Alesage d / Moyeu. Agujero d / Casquillo.	N. denti N. of teeth / Zähnezahl N. bre de dents Cantidad de dientes	Dp	De	Df	Dm	Di	F	S	R	Peso Weight Gewicht Poids Peso Kg		
Acciaio / Steel / Stahl Acier / Acero	con flangia / with flanges mit Flanges / avec flasques con tapetas	36-PC14M-90	6F	FL168	32	36	160,43	157,53	168,0	131	-	106	136	30,0	18,52		
		38-PC14M-90	6F	FL172	32	38	169,34	166,54	183,0	141	-	106	136	30,0	21,25		
		40-PC14M-90	6F	FL174	32	40	178,25	175,45	188,0	155	-	106	136	30,0	23,75		
		44-PC14M-90	6F	FL175	32	44	196,08	193,28	211,0	167	-	106	136	30,0	28,82		
		TL 48-PC14M-90	4F	FL180	3525	48	213,9	211,11	226,0	-	171	106	66	20,0	17,84		
Ghisa / Cast iron Grauguss / Fonte Hierro fundido	senza flangia / without flanges ohne Flanschen / sans flasques sin tapetas	TL 50-PC14M-90	4F	FL169	3525	50	222,82	220,02	240,0	-	180	106	66	20,0	18,32		
		TL 56-PC14M-90	4F	FL182	3525	56	249,55	246,76	256,0	-	207	106	66	20,0	23,54		
		TL 60-PC14M-90	4	-	3525	60	267,38	264,58	-	-	224	106	66	20,0	27,42		
		TL 64-PC14M-90	4	-	3525	64	285,21	282,41	-	-	242	106	66	20,0	31,45		
		TL 72-PC14M-90	9W	-	3525	72	320,86	318,06	-	178	278	106	66	20,0	47,05		
		TL 80-PC14M-90	9W	-	4030	80	356,51	353,71	-	215	314	106	76	15,0	58,85		
		TL 90-PC14M-90	9W	-	4030	90	401,07	398,27	-	215	360	106	76	15,0	71,76		
		TL 112-PC14M-90	9A	-	4535	112	499,11	496,31	-	215	456	106	90	8,0	105,81		
		TL 140-PC14M-90	9A	-	4535	140	623,89	621,09	-	215	581	106	90	8,0	135,46		
		TL 168-PC14M-90	9A	-	5040	168	748,66	745,87	-	267	708	106	102	2,0	193,77		
		TL 192-PC14M-90	9A	-	5040	192	855,61	852,82	-	267	812	106	102	2,0	249,78		

PC14M-125

Caratteristiche Features Merkmale Características		Descrizione Description Beschreibung Description Descripción	Tipo Type Typ Type Tipo	Codice flangia Flange code Bordscheiben- Code Code flasque Código brida	N. denti N. of teeth / Zähnezahl N. bre de dents Cantidad de dientes	Foro d / Bussola. Bush d / Bore. Bohrung d / Buchse. Alesage d / Moyeu. Agujero d / Casquillo.	Dp	De	Df	Dm	Di	F	S	R	Peso Weight Gewicht Poids Peso Kg
Acciaio / Steel Stahl / Acier Acero	con flangia / with flanges mit Flanges / avec flasques con tapetas	38-PC14M-125	6F	FL172	38	32	169,34	166,54	183,0	141	-	141	161	20,0	25,75
		40-PC14M-125	6F	FL174	40	32	178,25	175,45	188,0	155	-	141	161	20,0	28,73
		44-PC14M-125	6F	FL175	44	32	196,08	193,28	211,0	167	-	141	161	20,0	35,00
		48-PC14M-125	6F	FL180	48	32	213,9	211,11	226,0	185	-	141	161	20,0	41,93
Ghisa / Cast iron Grauguss / Fonte Hierro fundido	senza flangia / without flanges ohne Flanschen / sans flasques sin tapetas	TL 50-PC14M-125	4F	FL169	50	3525	222,82	220,02	240,0	-	180	141	65	38,0	21,42
		TL 56-PC14M-125	4F	FL182	56	3525	249,55	246,76	256,0	-	207	141	65	38,0	27,00
		TL 60-PC14M-125	4	-	60	4030	267,38	264,58	-	-	224	141	76	32,5	32,33
		TL 64-PC14M-125	4	-	64	4030	285,21	282,41	-	-	242	141	76	32,5	37,12
		TL 72-PC14M-125	9W	-	72	4030	320,86	318,06	-	215	278	141	76	32,5	65,74
		TL 80-PC14M-125	9W	-	80	4030	356,51	353,71	-	215	314	141	76	32,5	78,28
		TL 90-PC14M-125	9W	-	90	4030	401,07	398,27	-	215	360	141	76	32,5	95,46
		TL 112-PC14M-125	9A	-	112	4535	499,11	496,31	-	215	581	141	89	26,0	98,56
		TL 140-PC14M-125	9A	-	140	4535	623,89	621,09	-	215	581	141	89	26,0	180,19
		TL 168-PC14M-125	9A	-	168	5040	748,66	745,87	-	267	706	141	102	19,5	258,53
TL 192-PC14M-125	9A	-	192	5040	855,61	852,82	-	267	812	141	102	19,5	332,26		

DATI TECNICI – FLANGE PER PULEGGE DENTATE

TECHNICAL DATA – FLANGES FOR TIMING BELT PULLEYS

Flange non disponibili a stock

Flanges not available in stock

Codici delle flange Codes of flanges Codes der Bordscheiben Codes des flasques Códigos de las bridas	Tipo di puleggia (Profilo della dentatura) / Type of pulley (Toothing profile) Riemenscheibentyp (Verzahnungsprofil) / Type de poulie (Profil de denture) Tipo de polea (Perfil de los dientes)															
	MXL	XL	L	H	XH	XXH	3M	5M	8M	14M	PC GT 8M	PC GT 14M	T2.5	T5 ST5	T10 ST10	T20
10		FL001	FL050				FL501							FL003	FL007	
11		FL001	FL050											FL001	FL009	
12		FL002	FL052				FL502	FL014					FL501	FL001	FL013	
13		FL002	FL083										FL501	FL002	FL012	
14	F501A	FL004	FL054	FL059			FL503	FL002					FL502	FL002	FL011	
15		FL004	FL055	FL060			FL516	FL004					FL502	FL004	FL016	
16	FL502	FL005	FL056	FL061			FL504	FL004					FL503	FL005	FL018	
17		FL006	FL057	FL062									FL503	FL005	FL020	
18	FL503	FL007	FL058	FL063	FL155	FL163	FL505	FL006	F055A				FL504	FL006	FL021	FL075
19		FL007	FL059	FL064	FL156	FL164			F056A				FL505	FL008	FL024	
20	FL503	FL009	FL060	FL076	FL157	FL165	FL517	FL008	F052A				FL505	FL008	FL024	FL080
21		FL009	FL061	FL066	FL158	FL167	FL518	FL009					FL505	FL009	FL026	
22	FL504	FL010	FL062	FL067	FL159	FL169	FL518	FL015	FL053		FL053		FL512	FL009	FL027	FL085
23		FL013	FL063	FL068					F059A				FL512	FL010	FL027	
24	FL505	FL012	FL063	FL070	FL161	FL173	FL518	FL013	FL069				FL512	FL013	FL029	FL086
25		FL012	FL064	FL071	FL162						FL061		FL506	FL012	FL029	FL090
26		FL011	FL065	FL072	FL163	FL178	FL508	FL012	FL061				FL507	FL012	FL031	
27		FL011	FL065	FL074	FL164				F062A				FL507	FL011	FL032	
28	FL506	FL016	FL066	FL075	FL165		FL509	FL011	FL079	FL153	FL079	FL153	FL507	FL011	FL033	
29		FL016		FL075									FL507	FL016		
30	FL506	FL018	FL068	FL078	FL167		FL509	FL016	FL073	FL154	FL073	FL154	FL508	FL016	FL035	FL100
31	F506A															
32	FL507	FL020	FL070	FL080	FL169		FL510	FL018	FL076	FL160	FL076	FL160	FL509	FL018	FL038	
33			FL071	FL081									FL509			
34		FL022	FL072	FL081	FL170			FL020	FL066	FL166	FL066	FL171	FL509	FL021	FL072	
35		FL022	FL072	FL085					F067A				FL509	FL022		
36	FL508	FL023	FL074	FL085			FL519	FL021	FL068	FL168	FL068	FL168	FL510	FL023	FL043	
37										F168A			FL510	FL023		
38		FL024		FL086				FL024	FL070	FL172	FL070	FL172	FL510	FL024	FL078	
39		FL024						F024A								
40	FL509	FL026	FL078	FL090			FL513	FL025	FL077	FL162	FL077	FL174	FL511	FL024	FL047	
41		FL026														
42	FL509	FL027	FL080	FL094									FL511	FL026		
43		FL027														
44	FL510	FL027	FL081	FL095			FL520	FL027	FL075	FL175		FL175	FL513	FL027		
45			FL081	FL096					F075A		FL075			FL027	FL085	
46									F076A					FL029		
47										F180A						
48		FL029	FL085	FL0100				FL029	FL078	FL180	FL078	FL180	FL513	FL029	FL086	
50										F182A	FL080	FL169	FL514	FL031		
56		FL035						FL033	FL085	FL182	FL085	FL182				
60	F513A	FL038							F086A		FL086		FL515	FL038	FL100	
64	F514A							FL038	FL090	FL184	FL090					
72		F043A							FL043	FL097						
80										F100A						

Numero dei denti della puleggia (Z) / Teeth number of pulley (Z)
 Scheibenzähnezahl (Z) / Nombre de dents de la poulie (Z) / Número de dientes de la polea (Z)

DATI TECNICI – DIMENSIONI DELLE FLANGE TECHNICAL DATA – FLANGE DIMENSIONS

**Dimensioni delle flange / Flange dimensions
Bordscheiben-Abmessungen / Dimension de flasque
Dimensiones de las bridas**

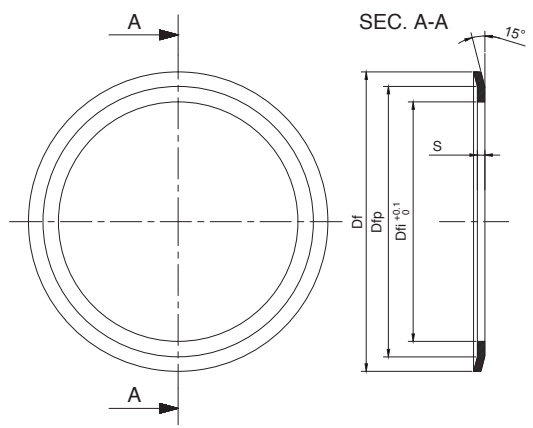

Codice flangia Flange code Bordscheiben- Code Code flasque Código brida	Dimensioni delle flange Flange dimensions Bordscheiben- Abmessungen Dimension de flasque Dimensiones de las bridas			
	Df	Dfi	Dfp	S
FL501	13,0	6,0	10,0	0,5
F501A	12,0	6,5	9,0	0,5
FL502	15,0	8,0	12,0	0,5
FL503	16,0	9,5	13,0	0,5
FL504	17,5	11,6	14,5	0,5
FL505	20,0	12,2	16,5	0,5
FL506	25,0	14,5	21,5	0,5
F506A	25,0	17,0	21,0	0,5
FL507	26,0	17,8	24,0	0,5
FL508	28,0	20,0	25,0	0,5
FL509	32,0	23,0	27,5	0,5
FL510	36,0	25,0	31,0	0,5
FL511	38,0	26,5	34,0	0,5
FL512	22,0	14,5	19,0	0,5
FL513	42,0	30,5	38,0	0,5
F513A	43,0	32,0	39,0	0,5
FL514	44,0	32,5	40,5	0,5
F514A	46,0	36,0	42,0	0,5
FL515	51,0	40,0	47,0	0,5
FL516	17,5	10,5	14,5	0,5
FL517	23,0	14,0	20,0	0,5
FL518	25,0	15,0	21,5	0,5
FL519	39,0	28,0	34,5	0,5
FL520	48,0	37,0	43,5	0,5

Codice flangia Flange code Bordscheiben- Code Code flasque Código brida	Dimensioni delle flange Flange dimensions Bordscheiben- Abmessungen Dimension de flasque Dimensiones de las bridas			
	Df	Dfi	Dfp	S
FL001	23,0	12,5	18,0	1,0
FL002	25,0	15,0	21,5	1,0
FL003	19,5	12,0	17,5	1,0
FL004	28,0	17,8	24,0	1,0
FL005	32,0	20,0	26,0	1,0
FL006	32,0	23,0	27,5	1,0
FL007	35,0	23,0	30,5	1,0
FL008	36,0	25,0	31,0	1,0
FL009	38,0	26,5	34,0	1,0
FL010	41,0	30,0	36,0	1,0
FL011	48,0	37,0	43,5	1,0
FL012	44,0	32,5	40,5	1,0
FL013	42,0	30,5	38,0	1,0
FL014	23,0	14,0	20,0	1,0
FL015	39,0	28,0	34,5	1,0
FL016	51,0	40,0	47,0	1,0
FL018	54,0	43,0	50,5	1,0
FL020	57,0	47,0	51,5	1,0
FL021	60,0	47,0	57,0	1,0
FL022	61,0	49,0	56,5	1,0
FL023	64,0	47,0	57,0	1,0
FL024	66,5	52,0	63,0	1,0
F024A	66,0	54,0	62,0	1,0
FL025	71,0	56,0	64,0	1,0
FL026	70,0	53,0	66,5	1,0
FL027	75,0	60,0	68,5	1,0
FL029	83,0	68,0	78,0	1,0
FL031	87,0	72,0	82,5	1,0
FL032	91,0	76,0	85,5	1,0
FL033	93,0	80,0	89,0	1,0
FL035	97,0	83,0	93,8	1,0
FL038	106,0	90,0	101,0	1,0
FL043	119,0	103,0	113,5	1,0
F043A	124,0	108,0	117,0	1,0
FL047	131,0	115,0	125,5	1,0

Codice flangia Flange code Bordscheiben- Code Code flasque Código brida	Dimensioni delle flange Flange dimensions Bordscheiben- Abmessungen Dimension de flasque Dimensiones de las bridas			
	Df	Dfi	Dfp	S
FL050	37,0	25,0	33,0	1,5
FL051	39,0	28,0	34,5	1,5
FL052	43,0	31,0	39,0	1,5
F052A	57,0	40,0	51,0	1,5
FL053	60,0	47,0	57,0	1,5
FL054	48,0	37,0	42,0	1,5
FL055	51,0	38,5	45,0	1,5
F055A	51,0	37,5	46,0	1,5
FL056	54,0	43,0	48,0	1,5
F056A	54,0	40,0	48,0	1,5
FL057	57,0	46,0	51,0	1,5
FL058	60,0	48,0	54,2	1,5
FL059	64,0	47,0	57,0	1,5
F059A	65,0	49,0	59,0	1,5
FL060	66,5	53,0	60,2	1,5
FL061	70,0	53,0	64,0	1,5
FL062	75,0	57,0	68,0	1,5
F062A	76,0	56,0	68,5	1,5
FL063	79,0	60,0	72,5	1,5
FL064	82,5	64,0	76,0	1,5
FL065	86,0	68,0	81,5	1,5
FL066	91,0	73,0	86,0	1,5
FL067	94,0	76,0	88,0	1,5
F067A	96,0	78,0	89,0	1,5
FL069	66,0	52,0	61,5	1,5
FL070	102,0	82,5	97,0	1,5
FL071	102,0	86,0	100,0	1,5
FL072	112,0	91,0	105,5	1,5
FL073	83,0	68,0	76,5	1,5
FL074	115,0	94,0	109,0	1,5
FL075	120,0	99,5	112,5	1,5
F075A	120,0	101,0	114,0	1,5
FL076	87,0	72,0	82,5	1,5
F076A	124,0	104,0	117,0	1,5
FL077	106,0	90,0	101,0	1,5
FL078	128,0	107,0	121,0	1,5
FL079	75,0	60,0	70,5	1,5
FL080	135,0	115,0	128,5	1,5
FL081	142,0	120,0	137,0	1,5
FL082	82,5	67,0	76,0	1,5
FL083	44,0	32,5	40,5	1,5
FL085	150,0	130,0	145,0	1,5
FL086	158,0	138,5	153,0	1,5
F086A	159,0	140,0	153,0	1,5
FL090	168,0	148,0	161,0	1,5
FL094	180,0	154,0	174,0	1,5
FL095	184,0	162,0	177,0	1,5
FL096	192,0	165,0	181,5	1,5
FL097	192,0	173,0	187,0	1,5
FL100	200,0	180,0	193,0	1,5
F100A	212,0	190,0	204,0	1,5
FL153	128,0	107,0	124,0	2,5

Codice flangia Flange code Bordscheiben- Code Code flasque Código brida	Dimensioni delle flange Flange dimensions Bordscheiben- Abmessungen Dimension de flasque Dimensiones de las bridas			
	Df	Dfi	Dfp	S
FL154	138,0	112,0	131,0	2,5
FL155	140,0	107,0	125,0	2,5
FL156	146,0	107,0	133,0	2,5
FL157	155,0	107,0	139,0	2,5
FL158	160,0	120,0	148,0	2,5
FL159	170,0	120,0	153,0	2,5
FL160	154,0	122,0	142,0	2,5
FL161	184,0	135,0	168,0	2,5
FL162	188,0	150,0	176,0	2,5
FL163	198,0	150,0	180,0	2,5
FL164	205,0	160,0	189,0	2,5
FL165	212,0	162,0	200,0	2,5
FL166	160,0	130,0	150,0	2,5
FL167	227,0	176,0	210,0	2,5
FL168	168,0	135,0	162,0	2,5
F168A	180,0	126,0	165,0	2,5
FL169	240,0	192,0	224,0	2,5
FL170	256,0	220,0	240,0	2,5
FL171	160,0	136,0	150,0	2,5
FL172	183,0	145,0	170,0	2,5
FL173	267,0	220,0	240,0	2,5
FL174	188,0	160,0	177,0	2,5
FL175	211,0	173,0	198,0	2,5
FL177	297,0	249,0	280,0	2,5
FL178	290,0	230,0	260,0	2,5
FL180	226,0	190,0	214,0	2,5
F180A	226,0	185,0	208,0	2,5
FL182	256,0	225,0	247,0	2,5
F182A	265,0	205,0	230,0	2,5
FL184	296,0	260,0	287,0	2,5

Informazioni tecniche Technical information Technische Informationen Informations techniques Información técnica
Materiale S235JR
Material S235JR
Werkstoff S235JR
Matière S235JR
Material S235JR
Sbavate e senza difetti sulla superficie Deburred and without defect on surface
Entgratet und mit mängelfreier Oberfläche
Ébavurées et sans défaut sur la surface
Desbarbado y sin defecto en la superficie

PIASTRE DI BLOCCAGGIO PER CINGHIE CLAMPING PLATES FOR BELTS

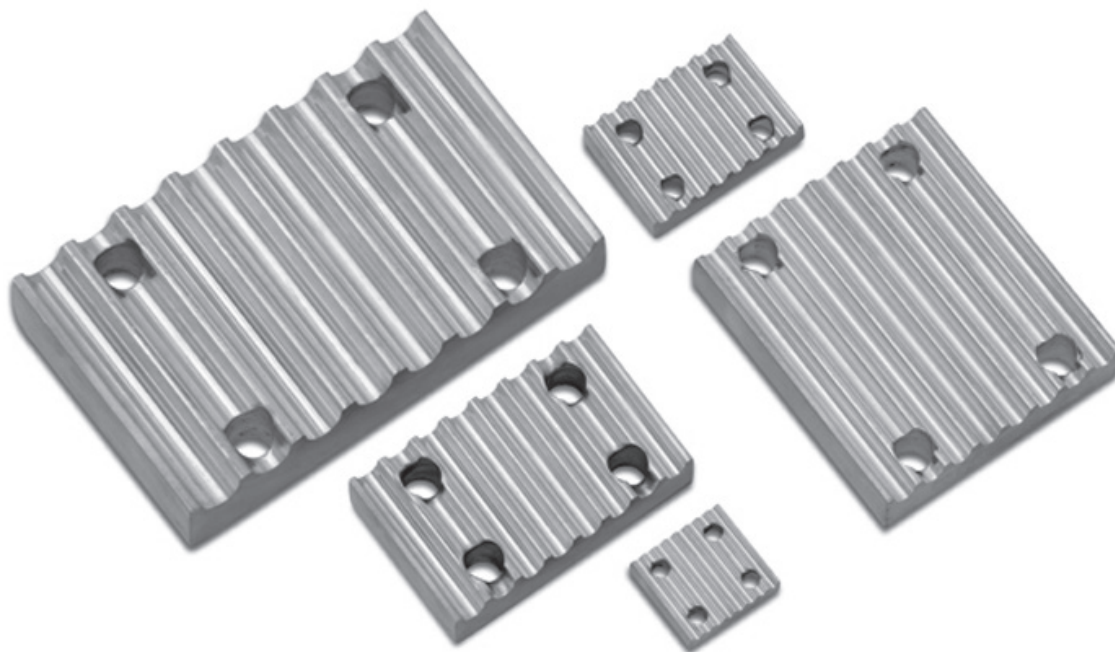

Le cinghie dentate, utilizzate per trasformare il moto rotatorio delle pulegge, in moto rettilineo alternato di tavole o di altri dispositivi, hanno la necessità di avere le estremità delle stesse ancorate alle parti mobili (fig. 1) o a quelle fisse (fig. 2) dei particolari da movimentare. Questo fissaggio deve essere eseguito con cura, per evitare che la cinghia possa essere danneggiata o indebolita nel punto di attacco. È stata realizzata pertanto questa serie di piastre che facilitano il corretto bloccaggio delle cinghie sui relativi ancoraggi.

The timing belts used for converting the rotary motion of the pulleys into linear motion of tables or other devices need to have their ends anchored to the mobile sections (fig. 1) or the fixed sections (fig. 2) of the parts to be moved. Such fastening must be done carefully to avoid the belt being damaged or weakened at the anchorage point. For this reason a set of plates has been created, that make it easier to lock the belt in the correct position on the relative anchorage points, has been created.

Bei Zahnriemen, die für die Übertragung der Rotationsbewegung der Scheibe in eine geradlinige abwechselnde Bewegung von Tischen oder anderen Vorrichtungen verwendet werden, müssen deren Enden am beweglichen (abb. 1) oder festen Teil (abb. 2) der anzutreibenden Elemente verankert werden. Diese Befestigung muß äußerst sorgfältig erfolgen, damit der Riemen nicht beschädigt oder an der Verbindungsstelle geschwächt wird. Aus diesem Grund wurde diese Serie von Platten realisiert, welche die korrekte Blockierung der Riemen an den entsprechenden Verankerungen vereinfachen.

Les extrémités des courroies dentées, utilisées pour transformer le mouvement rotatif des poulies, en un mouvement rectiligne alterné de plan ou autres dispositifs, doivent être ancrées dans les parties mobiles (fig. 1) ou dans celles fixes (fig. 2) des pièces à mettre en mouvement. Cette fixation doit être effectuée avec soin, pour éviter que la courroie puisse être endommagée ou affaiblie au niveau du point d'attache. Par conséquent, une série de plaques qui facilitent le blocage correct des courroies sur les ancrages correspondants, a été réalisée.

Las correas dentadas, que se utilizan para transformar el movimiento rotatorio de las poleas en movimiento rectilíneo alternado de mesas u otros dispositivos, deben tener los extremos anclados a las partes móviles (fig. 1) o fijas (fig. 2) de los elementos que se deben movilizar. Esta fijación se debe realizar con cuidado, para evitar que la correa se dañe o debilite en el punto de montaje. Para ello se ha realizado una serie de placas que facilitan el correcto bloqueo de las correas en sus respectivos anclajes.

Materiale:
alluminio 6082 T6 UNI 9006/4
adatto al trattamento anodico

Material:
aluminium 6082 T6 UNI
9006/4 suitable for anodic
treatment

Werkstoff:
aluminium 6082 T6 UNI 9006/4
geeignet für anodischen
oxydation

Matière:
aluminium 6082 T6 UNI
9006/4 apte au traitement
anodique

Material:
aluminio 6082 T6 UNI 9006/4
apto para la oxidación anodica

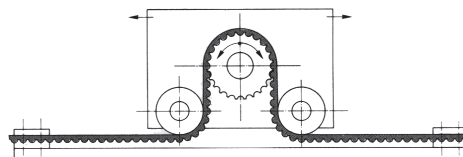
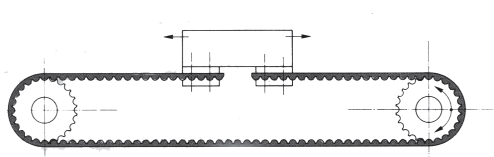

PIASTRE DI BLOCCAGGIO PER CINGHIE CLAMPING PLATES FOR BELTS

Caratteristiche Features Merkmale Características	Descrizione Description Beschreibung Description Descripción	Passo Pitch Teilung Pas Paso	A Larghezza della cinghia Belt width Riemenbreite Largeur de la courroie Anchura de la correa	B	b	d	e	L	H	
Piastre di bloccaggio per cinghie passo in pollici Clamping plates for belts imperial pitch Klemmplatten für Zahnriemen Zoll Reilung Plaques tendouses pour courroies pas en pouces Láminas tensoras para correas paso en pulgadas	PIASTRE BLOCC. XL 025	XL	25	25,5	6	5,5	3,5	42,5	8	
	PIASTRE BLOCC. XL 031	XL	31	27	6	5,5	3,5	42,5	8	
	PIASTRE BLOCC. XL 037	XL	37	28,5	6	5,5	3,5	42,5	8	
	PIASTRE BLOCC. L 050	L	50	39	8	9	5	76,6	15	
	PIASTRE BLOCC. L 075	L	75	45	8	9	5	76,6	15	
	PIASTRE BLOCC. L 100	L	100	51,5	8	9	5	76,6	15	
	PIASTRE BLOCC. H 050	H	50	45	10	11	9	106,9	22	
	PIASTRE BLOCC. H 075	H	75	51	10	11	9	106,9	22	
	PIASTRE BLOCC. H 100	H	100	57,5	10	11	9	106,9	22	
	Piastre di bloccaggio per cinghie passo metrico Clamping plates for metric belts Klemmplatten für Zahnriemen Plaques tendouses pour courroies metriques Laminas tensoras para correas metricast	PIASTRE BLOCC. T5-10	T5	10	29	6	5,5	3,2	41,4	
PIASTRE BLOCC. T5-16		T5	16	35	6	5,5	3,2	41,4	8	
PIASTRE BLOCC. T5-25		T5	25	44	6	5,5	3,2	41,4	8	
PIASTRE BLOCC. T10-16		T10	16	41	8	9	5	80	15	
PIASTRE BLOCC. T10-25		T10	25	50	8	9	5	80	15	
PIASTRE BLOCC. T10-32		T10	32	57	8	9	5	80	15	
PIASTRE BLOCC. T10-50		T10	50	75	8	9	5	80	15	
PIASTRE BLOCC. ST5-10		AT5	10	29	6	5,5	3,2	41,4	8	
PIASTRE BLOCC. ST5-16		AT5	16	35	6	5,5	3,2	41,4	8	
PIASTRE BLOCC. ST5-25		AT5	25	44	6	5,5	3,2	41,4	8	
PIASTRE BLOCC. ST10-16		AT10	16	41	8	9	5	80	15	
PIASTRE BLOCC. ST10-25		AT10	25	50	8	9	5	80	15	
PIASTRE BLOCC. ST10-32		AT10	32	57	8	9	5	80	15	
PIASTRE BLOCC. ST10-50		AT10	50	75	8	9	5	80	15	
Piastre di bloccaggio per cinghie HTD profile HTD profile Clamping plates for belts imperial pitch HTD profile Klemmplatten für Zahnriemen Plaques tendouses pour courroies HTD profile Láminas tensoras para correas HTD profile		PIASTRE BLOCC. 3M 06	3M	6	21	5	4,5	2	25	5
	PIASTRE BLOCC. 3M 10	3M	10	24	5	4,5	2	25	5	
	PIASTRE BLOCC. 3M 15	3M	15	30	5	4,5	2	25	5	
	PIASTRE BLOCC. 5M 10	5M	10	28	6	5,5	3,2	41,8	8	
	PIASTRE BLOCC. 5M 15	5M	15	34	6	5,5	3,2	41,8	8	
	PIASTRE BLOCC. 5M 25	5M	25	44	6	5,5	3,2	41,8	8	
	PIASTRE BLOCC. 8M 15	8M	15	40	8	9	5	66	15	
	PIASTRE BLOCC. 8M 20	8M	20	45	8	9	5	66	15	
	PIASTRE BLOCC. 8M 30	8M	30	55	8	9	5	66	15	
	PIASTRE BLOCC. 8M 50	8M	50	75	8	9	5	66	15	
	PIASTRE BLOCC. 8M 85	8M	85	110	8	9	5	66	15	
	PIASTRE BLOCC. 14M 40	14M	40	71	10	11	9	116	22	
	PIASTRE BLOCC. 14M 55	14M	55	86	10	11	9	116	22	
	PIASTRE BLOCC. 14M 85	14M	85	116	10	11	9	116	22	
	PIASTRE BLOCC. 14M 115	14M	115	146	10	11	9	116	22	
	PIASTRE BLOCC. 14M 170	14M	170	201	10	11	9	116	22	

PULEGGE TRAPEZOIDALI PV PV BELT PULLEYS



PULEGGE TRAPEZOIDALI PV PV BELT PULLEYS

Le pulegge per cinghie PV presentate dalla Megadyne nel presente catalogo sono tutte costruite secondo le tabelle ISO 9982.

PV pulleys proposed by Megadyne in this catalogue are all manufactured according to ISO 9982.

Die PV Riemenscheiben, die von Megadyne in diesem Katalog dargestellt sind, sind alle nach ISO 9982.

Les poulies PV présentées par la Megadyne sur ce catalogue sont toutes fabriquées suivant les normes ISO 9982.

Las poleas PV presentadas por la Megadyne en el presente catálogo están todas construidas según las tablas ISO 9982.

Il materiale impiegato nella costruzione delle medesime è in ghisa EN-GJL-200 UNI EN 1561 e, successivamente alle lavorazioni meccaniche, subiscono un trattamento superficiale di FOSFATAZIONE.

The material used for the construction of these pulleys is cast iron EN-GJL-200 UNI EN 1561 and after the machining all pulleys are being PHOSPHATED.

Das fuer die Produktion verwendende Material ist Grauguss EN-GJL-200 UNI EN 1561 und nach der Bearbeitung werden alle Keilriemenscheiben PHOSPHATIERT.

Le materiel utilisé pour la fabrication des poulies est la fonte EN-GJL-200 UNI EN 1561 et après l'usinage elles sont toutes exposées à un traitement de PHOSPHATATION.

El material empleado en la construcción de las mismas es el hierro fundido EN-GJL-200 UNI EN 1561 y después de las elaboraciones mecánicas están sometidas a un tratamiento superficial de FOSFATACIÓN.

Tutte le pulegge sono equilibrate STATICAMENTE ed idonee ad un funzionamento fino alla velocità periferica di 30 m/s.

All pulleys are STATICALLY balanced and suitable for peripheral speed up to 30 m/s.

Alle Keilriemenscheiben sind STATISCH ausgewuchtet und fuer eine peripherische Betriebsgeschwindigkeit bis 30 m/s.

Toutes les poulies sont équilibrées STATIQUEMENT et propres à tourner à une vitesse périphérique jusqu'à 30 m/s.

Todas las poleas están equilibradas ESTÁTICAMENTE y son adecuadas para un funcionamiento de una velocidad de hasta 30 m/s.

Calcolo della velocità periferica V_p in m/s:

Calculation of peripheral speed V_p in m/s

Berechnung der Umfangsgeschwindigkeit V_p in m/s

Calcul de la vitesse périphérique V_p m/s

Cálculo de la velocidad periférica V_p en m/s

$$V_p = \frac{p \cdot P \cdot \text{rpm}}{60 \cdot 1000} @ \frac{P \cdot \text{rpm}}{19100} ; V_p \leq 30 \text{ m/s}$$

P= Diametro primitivo in mm
rpm= Giri al minuto

P= Pitch diameter in mm
rpm= Revolutions per minute

P= Teildurchmesser in mm
rpm= Umdrehungen pro Minute

P= Diamètre primitif en mm
rpm= Tours par minute

P= Diámetro primitivo en mm
rpm= Revoluciones por minuto

Estratto ISO 9982 Extract of ISO 9982 Auszug aus ISO 9982 Extrait de ISO 9982 Extracto de ISO 9982

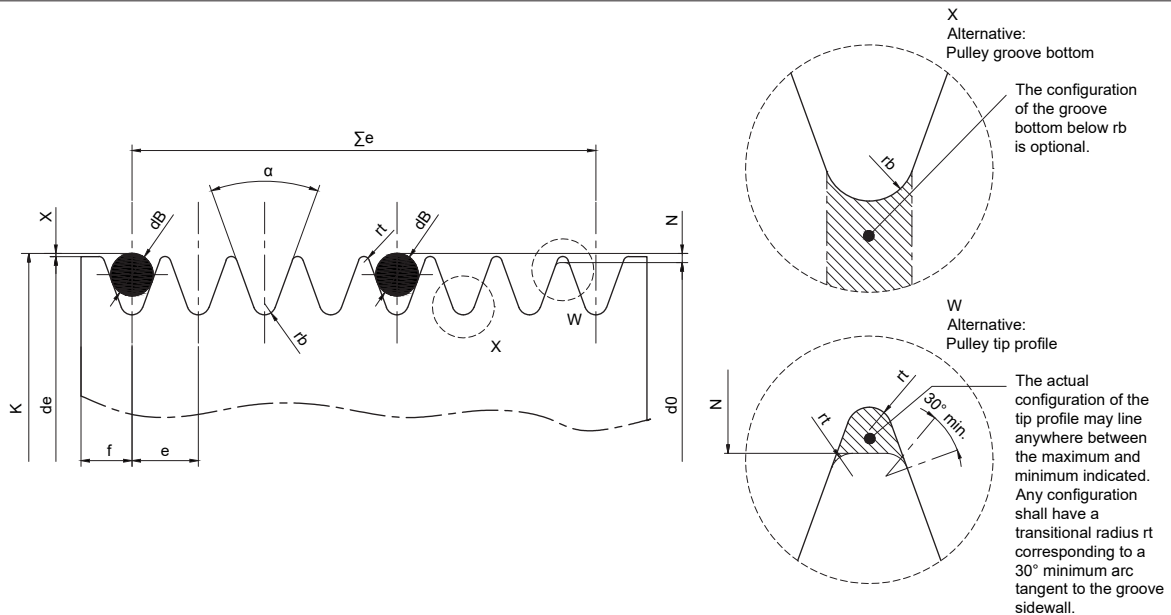

	Grooves	e ^{1) 2)}	$\sum e$ $\pm 0,3$	α ³⁾ $\pm 0,5^\circ$	R_t min.	R_b max.	d_B $\pm 0,01$	$2X$ nom.	$2N$ ⁴⁾ max.	f min.	
PJ	8	2,34	$\pm 0,03$	16,38	40°	0,2	0,4	1,5	0,23	0,81	1,80
	12	2,34	$\pm 0,03$	25,74	40°	0,2	0,4	1,5	0,23	0,81	1,80
	16	2,34	$\pm 0,03$	35,1	40°	0,2	0,4	1,5	0,23	0,81	1,80
PL	8	4,7	$\pm 0,05$	32,9	40°	0,4	0,4	3,5	2,36	3,5	3,30
	12	4,7	$\pm 0,05$	51,7	40°	0,4	0,4	3,5	2,36	3,5	3,30
	16	4,7	$\pm 0,05$	70,5	40°	0,4	0,4	3,5	2,36	3,5	3,30

1) The tolerance on e applies to the distance between the axes of two consecutive grooves.
 2) The sum of all deviations from the nominat value e for all grooves in any pulley shall not exceed $\pm 0,3$.
 3) The centreline of the groove shall make an angle of $90^\circ \pm 0,5^\circ$ with the axis of the pulley.
 4) N is not related to the nominal diameter of the pulley but is measured from the actual ride position of the ball or rod in the pulley.

PULEGGE TRAPEZOIDALI PV PV BELT PULLEYS

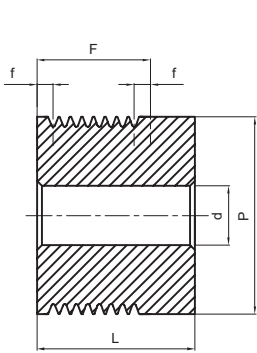

Tipo / Type / Typ
Type / Tipo :
1

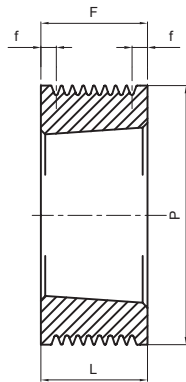

Tipo / Type / Typ
Type / Tipo :
2

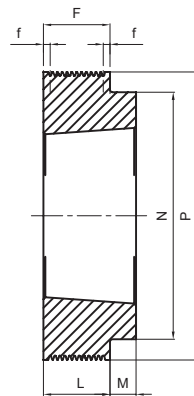

Tipo / Type / Typ
Type / Tipo :
4

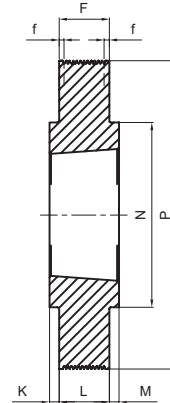

Tipo / Type / Typ
Type / Tipo :
5

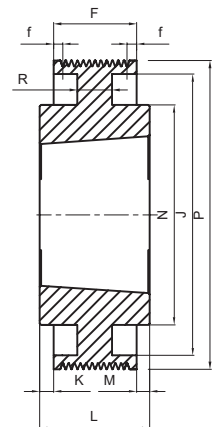

Tipo / Type / Typ
Type / Tipo :
8

PV PJ 8

Descrizione Description Beschreibung Description Descripción	Gole Grooves Rillen Gorges Canales	P	Tipo Type Typ Type Tipo	Foro d / Bussola Bush d / Bore Bohrung d / Buchse Alesage d / Moyeu Agujero d / Casquillo	ø MAX	F ±0.1	f	J	K	L	M	N	R	Peso Weight Gewicht Poids Peso Kg
40 PJ 8	8	40	1	12	-	23,0	3,31	-	-	32	-	-	-	0,24
45 PJ 8	8	45	1	12	-	23,0	3,31	-	-	32	-	-	-	0,32
50 PJ 8	8	50	1	12	-	23,0	3,31	-	-	32	-	-	-	0,40
56 PJ 8	8	56	2	1108	28	23,0	3,31	-	-	23	-	-	-	0,39
63 PJ 8	8	63	2	1108	28	23,0	3,31	-	-	23	-	-	-	0,50
71 PJ 8	8	71	2	1108	28	23,0	3,31	-	-	23	-	-	-	0,64
75 PJ 8	8	75	2	1108	28	23,0	3,31	-	-	23	-	-	-	0,72
80 PJ 8	8	80	4	1610	42	23,0	3,31	-	-	26	3	70	-	0,41
85 PJ 8	8	85	4	1610	42	23,0	3,31	-	-	26	3	70	-	0,51
90 PJ 8	8	90	4	1610	42	23,0	3,31	-	-	26	3	70	-	0,62
95 PJ 8	8	95	4	1610	42	23,0	3,31	-	-	26	3	82	-	0,78
100 PJ 8	8	100	4	1610	42	23,0	3,31	-	-	26	3	82	-	0,90
106 PJ 8	8	106	4	1610	42	23,0	3,31	-	-	26	3	82	-	1,05
112 PJ 8	8	112	4	1610	42	23,0	3,31	-	-	26	3	90	-	1,25
118 PJ 8	8	118	4	1610	42	23,0	3,31	-	-	26	3	90	-	1,43
125 PJ 8	8	125	4	1610	42	23,0	3,31	-	-	26	3	90	-	1,64
132 PJ 8	8	132	4	1610	42	23,0	3,31	-	-	26	3	90	-	1,88
140 PJ 8	8	140	4	1610	42	23,0	3,31	-	-	26	3	90	-	1,60
160 PJ 8	8	160	5	2012	50	23,0	3,31	-	4,5	32	4,5	110	-	3,01
180 PJ 8	8	180	5	2012	50	23,0	3,31	-	4,5	32	4,5	110	-	3,92
190 PJ 8	8	190	5	2012	50	23,0	3,31	-	4,5	32	4,5	110	-	4,38
200 PJ 8	8	200	5	2012	50	23,0	3,31	-	4,5	32	4,5	110	-	4,88
212 PJ 8	8	212	5	2012	50	23,0	3,31	-	4,5	32	4,5	110	-	5,49
224 PJ 8	8	224	5	2012	50	23,0	3,31	-	4,5	32	4,5	110	-	6,17
250 PJ 8	8	250	5	2012	50	23,0	3,31	-	4,5	32	4,5	110	-	7,73
280 PJ 8	8	280	8	2012	50	23,0	3,31	260	4,5	32	4,5	110	10	5,78
315 PJ 8	8	315		2012	50	23,0	3,31	295	4,5	32	4,5	110	10	6,92

PULEGGE TRAPEZOIDALI PV PV BELT PULLEYS

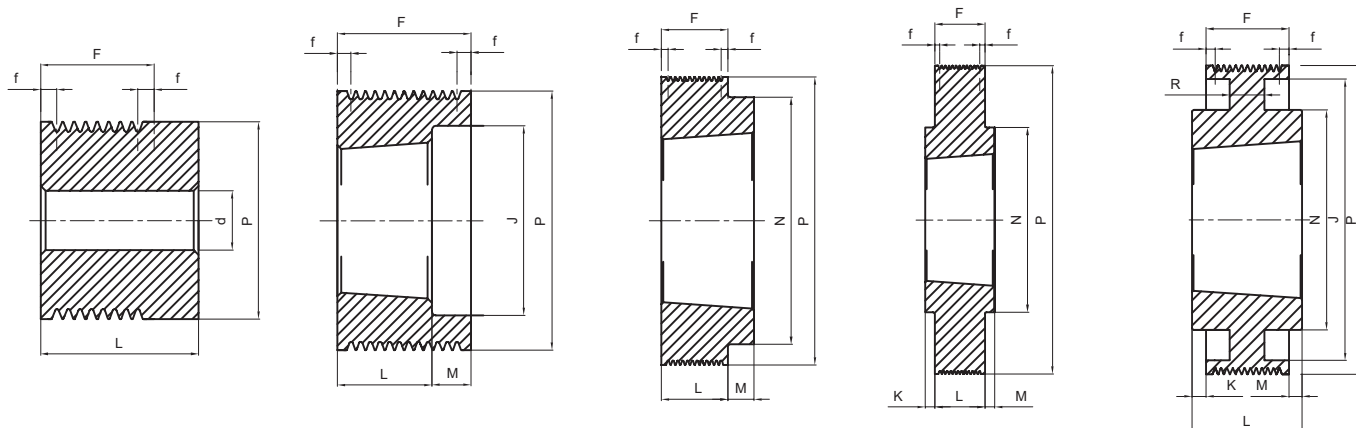

Tipo / Type / Typ
Type / Tipo :
1

Tipo / Type / Typ
Type / Tipo :
3

Tipo / Type / Typ
Type / Tipo :
4

Tipo / Type / Typ
Type / Tipo :
5

Tipo / Type / Typ
Type / Tipo :
8

PV PJ 12

Descrizione Description Beschreibung Description Descripción	Gole Grooves Rillen Gorges Canales	P	Tipo Type Typ Type Tipo	Foro d / Bussola. Bush d / Bore Bohrung d / Buchse Alesage d / Moyeu Agujero d / Casquillo	ø MAX	F ±0.1	f	J	K	L	M	N	R	Peso Weight Gewicht Poids Peso Kg
40 PJ 12	12	40	1	12	-	32,5	3,38	-	-	41,5	-	-	-	0,31
45 PJ 12	12	45	1	12	-	32,5	3,38	-	-	41,5	-	-	-	0,41
50 PJ 12	12	50	1	12	-	32,5	3,38	-	-	41,5	-	-	-	0,52
56 PJ 12	12	56	1	12	-	32,5	3,38	-	-	41,5	-	-	-	0,65
63 PJ 12	12	63	3	1108	28	32,5	3,38	46	-	23	9,5	-	-	0,39
71 PJ 12	12	71	3	1108	28	32,5	3,38	46	-	23	9,5	-	-	0,57
75 PJ 12	12	75	3	1610	42	32,5	3,38	60	-	26	6,5	-	-	0,38
80 PJ 12	12	80	3	1610	42	32,5	3,38	60	-	26	6,5	-	-	0,52
85 PJ 12	12	85	3	1610	42	32,5	3,38	60	-	26	6,5	-	-	0,66
90 PJ 12	12	90	3	1610	42	32,5	3,38	74	-	26	6,5	-	-	0,76
95 PJ 12	12	95	3	1610	42	32,5	3,38	74	-	26	6,5	-	-	0,93
100 PJ 12	12	100	3	1610	42	32,5	3,38	74	-	26	6,5	-	-	1,10
106 PJ 12	12	106	3	1610	42	32,5	3,38	88	-	26	6,5	-	-	1,24
112 PJ 12	12	112	3	1610	42	32,5	3,38	88	-	26	6,5	-	-	1,47
118 PJ 12	12	118	3	2012	50	32,5	3,38	98	-	32	0,5	-	-	1,55
125 PJ 12	12	125	3	2012	50	32,5	3,38	98	-	32	0,5	-	-	1,90
132 PJ 12	12	132	3	2012	50	32,5	3,38	98	-	32	0,5	-	-	2,21
140 PJ 12	12	140	4	2517	65	32,5	3,38	-	-	45	12,5	120	-	7,10
160 PJ 12	12	160	4	2517	65	32,5	3,38	-	-	45	12,5	120	-	3,80
180 PJ 12	12	180	5	2517	65	32,5	3,38	-	6,25	45	6,25	120	-	5,03
190 PJ 12	12	190	5	2517	65	32,5	3,38	-	6,25	45	6,25	120	-	5,72
200 PJ 12	12	200	5	2517	65	32,5	3,38	-	6,25	45	6,25	120	-	6,40
212 PJ 12	12	212	5	2517	65	32,5	3,38	-	6,25	45	6,25	120	-	7,33
224 PJ 12	12	224	5	2517	65	32,5	3,38	-	6,25	45	6,25	120	-	8,29
250 PJ 12	12	250	5	2517	65	32,5	3,38	-	6,25	45	6,25	120	-	10,47
280 PJ 12	12	280	8	2517	65	32,5	3,38	260	6,25	45	6,25	120	10	7,38
315 PJ 12	12	315	8	2517	65	32,5	3,38	295	6,25	45	6,25	120	10	8,99

PULEGGE TRAPEZOIDALI PV PV BELT PULLEYS

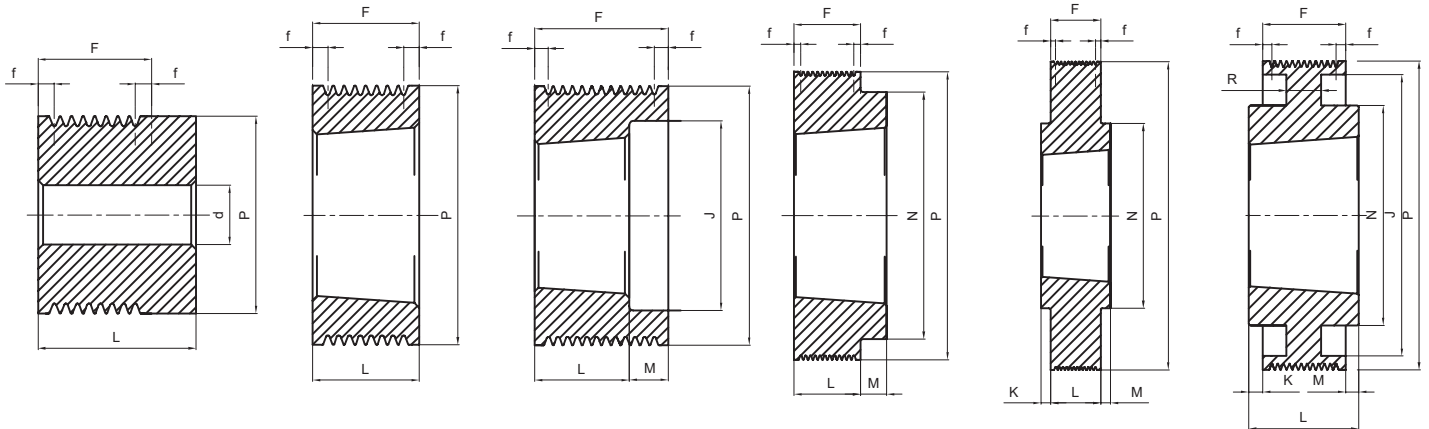

Tipo / Type / Typ
Type / Tipo :
1

Tipo / Type / Typ
Type / Tipo :
2

Tipo / Type / Typ
Type / Tipo :
3

Tipo / Type / Typ
Type / Tipo :
4

Tipo / Type / Typ
Type / Tipo :
5

Tipo / Type / Typ
Type / Tipo :
8

PV PJ 16

Descrizione Description Beschreibung Description Descripción	Gole Grooves Rillen Gorges Canales	P	Tipo Type Typ Type Tipo	Foro d / Bussola. Bush d / Bore Bohrung d / Buchse Alesage d / Moyeu Agujero d / Casquillo	Ø MAX	F ±0.1	f	J	K	L	M	N	R	Peso Weight Gewicht Poids Peso Kg
40 PJ 16	16	40	1	12	-	42,0	3,45	-	-	51	-	-	-	0,38
45 PJ 16	16	45	1	12	-	42,0	3,45	-	-	51	-	-	-	0,50
50 PJ 16	16	50	1	12	-	42,0	3,45	-	-	51	-	-	-	0,63
56 PJ 16	16	56	1	12	-	42,0	3,45	-	-	51	-	-	-	0,81
63 PJ 16	16	63	1	12	-	42,0	3,45	-	-	51	-	-	-	1,05
71 PJ 16	16	71	2	1215	32	42,0	3,45	-	-	42	-	-	-	0,63
75 PJ 16	16	75	3	1610	42	42,0	3,45	60	-	26	16	-	-	0,46
80 PJ 16	16	80	3	1610	42	42,0	3,45	60	-	26	16	-	-	0,64
85 PJ 16	16	85	3	1610	42	42,0	3,45	60	-	26	16	-	-	0,84
90 PJ 16	16	90	3	1610	42	42,0	3,45	74	-	26	16	-	-	0,87
95 PJ 16	16	95	3	1610	42	42,0	3,45	74	-	26	16	-	-	1,08
100 PJ 16	16	100	3	1610	42	42,0	3,45	74	-	26	16	-	-	1,32
106 PJ 16	16	106	3	1610	42	42,0	3,45	88	-	26	16	-	-	1,40
112 PJ 16	16	112	3	1610	42	42,0	3,45	88	-	26	16	-	-	1,70
118 PJ 16	16	118	3	2012	50	42,0	3,45	98	-	32	10	-	-	1,79
125 PJ 16	16	125	3	2012	50	42,0	3,45	98	-	32	10	-	-	2,18
132 PJ 16	16	132	3	2012	50	42,0	3,45	98	-	32	10	-	-	2,60
140 PJ 16	16	140	4	2517	65	42,0	3,45	-	-	45	3	120	-	9,60
160 PJ 16	16	160	4	2517	65	42,0	3,45	-	-	45	3	120	-	4,37
180 PJ 16	16	180	5	2517	65	42,0	3,45	-	1,5	45	1,5	120	-	5,97
190 PJ 16	16	190	5	2517	65	42,0	3,45	-	1,5	45	1,5	120	-	6,85
200 PJ 16	16	200	5	2517	65	42,0	3,45	-	1,5	45	1,5	120	-	7,75
212 PJ 16	16	212	5	2517	65	42,0	3,45	-	1,5	45	1,5	120	-	8,90
224 PJ 16	16	224	5	2517	65	42,0	3,45	-	1,5	45	1,5	120	-	10,10
250 PJ 16	16	250	5	2517	65	42,0	3,45	-	1,5	45	1,5	120	-	13,00
280 PJ 16	16	280	8	2517	65	42,0	3,45	260	1,5	45	1,5	120	12	8,38
315 PJ 16	16	315	8	2517	65	42,0	3,45	295	1,5	45	1,5	120	12	9,57

PULEGGE TRAPEZOIDALI PV PV BELT PULLEYS

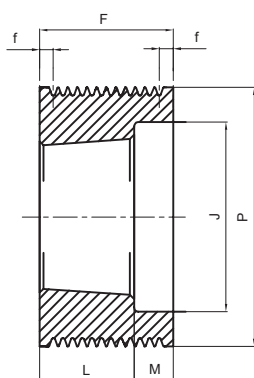

Tipo / Type / Typ
Type / Tipo :
3

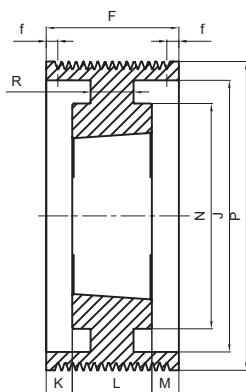

Tipo / Type / Typ
Type / Tipo :
7

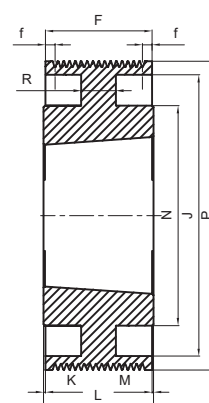

Tipo / Type / Typ
Type / Tipo :
8

PV PL 8

Descrizione Description Beschreibung Description Descripción	Gole Grooves Rillen Gorges Canales	P	Tipo Type Typ Type Tipo	Bussola Bush Buchse Moyeu Casquillo	ø MAX	F ±0.1	f	J	K	L	M	N	R	Peso Weight Gewicht Poids Peso Kg
75 PL 8	8	75	3	1210	32	48,0	7,55	56	-	26	22	-	-	0,66
80 PL 8	8	80	3	1210	32	48,0	7,55	56	-	26	22	-	-	0,86
85 PL 8	8	85	3	1210	32	48,0	7,55	61	-	26	22	-	-	1,00
90 PL 8	8	90	3	1610	42	48,0	7,55	66	-	26	22	-	-	1,01
95 PL 8	8	95	3	1610	42	48,0	7,55	71	-	26	22	-	-	1,16
100 PL 8	8	100	3	1610	42	48,0	7,55	76	-	26	22	-	-	1,31
106 PL 8	8	106	3	1610	42	48,0	7,55	82	-	26	22	-	-	1,53
112 PL 8	8	112	3	1610	42	48,0	7,55	88	-	26	22	-	-	1,75
118 PL 8	8	118	3	2012	50	48,0	7,55	94	-	32	16	-	-	1,88
125 PL 8	8	125	3	2012	50	48,0	7,55	101	-	32	16	-	-	2,22
132 PL 8	8	132	3	2012	50	48,0	7,55	108	-	32	16	-	-	2,54
140 PL 8	8	140	3	2517	65	48,0	7,55	116	-	45	3	-	-	3,02
150 PL 8	8	150	3	2517	65	48,0	7,55	126	-	45	3	-	-	3,75
160 PL 8	8	160	3	2517	65	48,0	7,55	136	-	45	3	-	-	4,54
170 PL 8	8	170	3	2517	65	48,0	7,55	146	-	45	3	-	-	5,35
180 PL 8	8	180	7	2517	65	48,0	7,55	156	1,5	45	1,5	120	14	4,52
190 PL 8	8	190	7	2517	65	48,0	7,55	166	1,5	45	1,5	120	12	4,72
200 PL 8	8	200	7	2517	65	48,0	7,55	176	1,5	45	1,5	120	12	5,07
212 PL 8	8	212	7	2517	65	48,0	7,55	188	1,5	45	1,5	120	12	5,50
224 PL 8	8	224	7	2517	65	48,0	7,55	202	1,5	45	1,5	120	12	5,77
250 PL 8	8	250	8	3020	75	48,0	7,55	228	2	52	2	146	12	7,39
280 PL 8	8	280	8	3020	75	48,0	7,55	256	2	52	2	146	12	8,90
315 PL 8	8	315	8	3020	75	48,0	7,55	285	2	52	2	146	12	11,30

PULEGGE TRAPEZOIDALI PV PV BELT PULLEYS

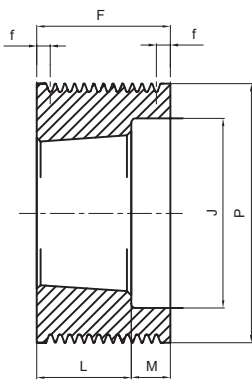

Tipo / Type / Typ
Type / Tipo :
3

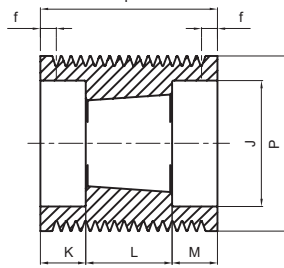

Tipo / Type / Typ
Type / Tipo :
6

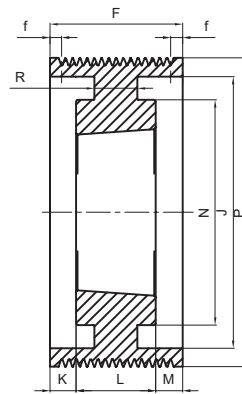

Tipo / Type / Typ
Type / Tipo :
7

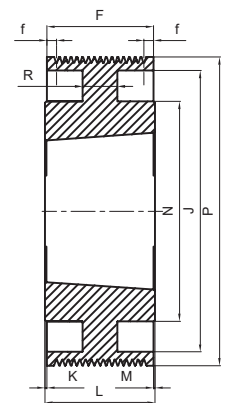

Tipo / Type / Typ
Type / Tipo :
8

PV PL 12

Descrizione Description Beschreibung Description Descripción	Gole Grooves Rillen Gorges Canales	P	Tipo Type Typ Type Tipo	Bussola Bush Buchse Moyeu Casquillo	∅ MAX	F ±0.1	f	J	K	L	M	N	R	Peso Weight Gewicht Poids Peso Kg
75 PL 12	12	75	3	1215	28	67,0	7,65	56	-	42	25	-	-	0,97
80 PL 12	12	80	3	1215	28	67,0	7,65	56	-	42	25	-	-	1,25
85 PL 12	12	85	3	1215	28	67,0	7,65	61	-	42	25	-	-	1,47
90 PL 12	12	90	3	1615	42	67,0	7,65	66	-	42	25	-	-	1,45
95 PL 12	12	95	3	1615	42	67,0	7,65	71	-	42	25	-	-	1,71
100 PL 12	12	100	3	2012	50	67,0	7,65	79	-	32	35	-	-	1,39
106 PL 12	12	106	3	2012	50	67,0	7,65	82	-	32	35	-	-	1,73
112 PL 12	12	112	3	2012	50	67,0	7,65	88	-	32	35	-	-	2,02
118 PL 12	12	118	6	2517	65	67,0	7,65	97	11	45	11	-	-	1,96
125 PL 12	12	125	6	2517	65	67,0	7,65	101	11	45	11	-	-	2,46
132 PL 12	12	132	6	2517	65	67,0	7,65	108	11	45	11	-	-	2,97
140 PL 12	12	140	6	2517	65	67,0	7,65	116	11	45	11	-	-	3,55
150 PL 12	12	150	6	2517	65	67,0	7,65	126	11	45	11	-	-	4,30
160 PL 12	12	160	6	2517	65	67,0	7,65	136	11	45	11	-	-	5,12
170 PL 12	12	170	6	2517	65	67,0	7,65	146	11	45	11	-	-	6,03
180 PL 12	12	180	7	2517	65	67,0	7,65	156	11	45	11	120	16	5,34
190 PL 12	12	190	7	2517	65	67,0	7,65	166	11	45	11	120	14	5,60
200 PL 12	12	200	7	3020	75	67,0	7,65	176	7,5	52	7,5	146	22	6,99
212 PL 12	12	212	7	3020	75	67,0	7,65	188	7,5	52	7,5	146	14	7,06
224 PL 12	12	224	7	3020	75	67,0	7,65	202	7,5	52	7,5	146	14	7,41
250 PL 12	12	250	7	3020	75	67,0	7,65	228	7,5	52	7,5	146	14	8,67
280 PL 12	12	280	7	3020	75	67,0	7,65	256	7,5	52	7,5	146	14	10,58
315 PL 12	12	315	8	3535	90	67,0	7,65	285	11	89	11	178	14	18,23

PULEGGE TRAPEZOIDALI PV PV BELT PULLEYS

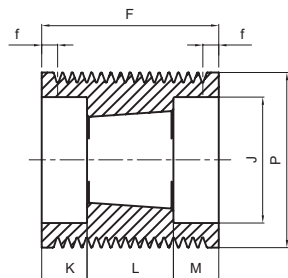

Tipo / Type / Typ
Type / Tipo :
6

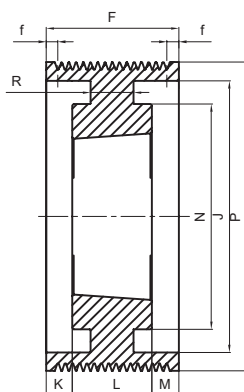

Tipo / Type / Typ
Type / Tipo :
7

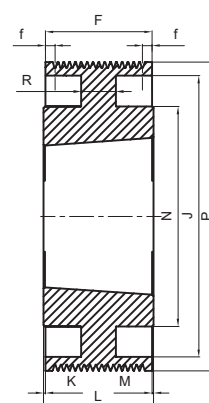

Tipo / Type / Typ
Type / Tipo :
8

PV PL 16

Descrizione Description Beschreibung Description Descripción	Gole Grooves Rillen Gorges Canales	P	Tipo Type Typ Type Tipo	Bussola Bush Buchse Moyeu Casquillo	ø MAX	F ±0.1	f	J	K	L	M	N	R	Peso Weight Gewicht Poids Peso Kg
85 PL 16	16	85	6	1215	28	86,0	7,75	61	22	42	22	-	-	1,76
90 PL 16	16	90	6	1615	42	86,0	7,75	66	22	42	22	-	-	1,78
95 PL 16	16	95	6	1615	42	86,0	7,75	71	22	42	22	-	-	2,02
100 PL 16	16	100	6	2012	50	86,0	7,75	79	27	32	27	-	-	1,69
106 PL 16	16	106	6	2012	50	86,0	7,75	82	27	32	27	-	-	2,12
112 PL 16	16	112	6	2012	50	86,0	7,75	88	27	32	27	-	-	2,42
118 PL 16	16	118	6	2517	65	86,0	7,75	97	20,5	45	20,5	-	-	2,31
125 PL 16	16	125	6	2517	65	86,0	7,75	101	20,5	45	20,5	-	-	2,92
132 PL 16	16	132	6	2517	65	86,0	7,75	108	20,5	45	20,5	-	-	3,44
140 PL 16	16	140	6	2517	65	86,0	7,75	116	20,5	45	20,5	-	-	4,05
150 PL 16	16	150	6	2517	65	86,0	7,75	126	20,5	45	20,5	-	-	4,85
160 PL 16	16	160	6	3020	75	86,0	7,75	136	17	52	17	-	-	4,88
170 PL 16	16	170	6	3020	75	86,0	7,75	146	17	52	17	-	-	5,96
180 PL 16	16	180	6	3020	75	86,0	7,75	156	17	52	17	-	-	7,09
190 PL 16	16	190	6	3020	75	86,0	7,75	166	17	52	17	-	-	8,20
200 PL 16	16	200	7	3020	75	86,0	7,75	176	17	52	17	146	25	7,92
212 PL 16	16	212	7	3020	75	86,0	7,75	188	17	52	17	146	16	8,03
224 PL 16	16	224	7	3020	75	86,0	7,75	202	17	52	17	146	16	8,42
250 PL 16	16	250	8	3535	90	86,0	7,75	228	1,5	89	1,5	178	30	16,09
280 PL 16	16	280	8	3535	90	86,0	7,75	256	1,5	89	1,5	178	18	17,10
315 PL 16	16	315	8	3535	90	86,0	7,75	285	1,5	89	1,5	178	18	20,93

PULEGGE TRAPEZOIDALI PER BUSSOLA CONICA
V-BELT PULLEYS FOR TAPER BUSHES



PULEGGE TRAPEZOIDALI PER BUSSOLA CONICA V-BELT PULLEYS FOR TAPER BUSHES

Le pulegge per cinghie trapezoidali presentate dalla Megadyne nel presente catalogo sono tutte costruite secondo le tabelle ISO 4183 e DIN 2211-3.

Il materiale impiegato nella costruzione delle medesime è in ghisa EN-GJL-200 UNI EN 1561 e, successivamente alle lavorazioni meccaniche, subiscono un trattamento superficiale di FOSFATAZIONE.

Tutte le pulegge sono equilibrate STATICAMENTE ed idonee ad un funzionamento fino alla velocità periferica di 35 m/s.

La gamma proposta nel seguente catalogo, comprende:
PULEGGE TRAPEZOIDALI, per bussola conica, serie ZT..... AT..... BT..... CT.....
PULEGGE TRAPEZOIDALI monoblocco (con mozzo pieno) serie ZM..... AM..... BM..... CM.....
PULEGGE TRAPEZOIDALI per calettatore.

V-belt pulleys proposed by Megadyne in this catalogue are all manufactured according to ISO 4183 and DIN 2211-3 norms.

The material used for the construction of these pulleys is cast iron EN-GJL-200 UNI EN 1561 and after the machining all pulleys are being PHOSPHATED.

All pulleys are STATICALLY balanced and suitable for peripheral speed up to 35 m/s.

The range proposed in this catalogue is the following:
V-BELT PULLEYS for taper bush, series ZT..... AT..... BT..... CT.....
V-BELT PULLEYS with solid hub, series ZM..... AM..... BM..... CM.....
V-BELT PULLEYS for locking devices.

Die Keilriemenscheiben, die von Megadyne in diesem Katalog dargestellt sind, sind alle nach ISO 4183 und DIN 2211-3 hergestellt worden.

Das fuer die Produktion verwendete Material ist Grauguss EN-GJL-200 UNI EN 1561 und nach der Bearbeitung werden alle Keilriemenscheiben PHOSPHATIERT.

Alle Keilriemenscheiben sind STATISCH ausgewuchtet und fuer eine peripherische Betriebsgeschwindigkeit bis 35 m/s.

Die in diesem Katalog angegebene Palette ist die folgende:
KEILRIEMENSCHLEIBEN fuer Spannbuchse, Serie ZT..... AT..... BT..... CT.....
KEILRIEMENSCHLEIBEN ungebohrt, Serie ZM..... AM..... BM..... CM.....
KEILRIEMENSCHLEIBEN fuer Spannsätze.

Les poulies trapézoïdales présentées par la Megadyne sur ce catalogue sont toutes fabriquées suivant les normes ISO 4183 et DIN 2211-3.

Le matériel utilisé pour la fabrication des poulies est la fonte EN-GJL-200 UNI EN 1561 et après l'usinage elles sont toutes exposées à un traitement de PHOSPHATATION.

Toutes les poulies sont équilibrées STATIQUEMENT et propres à tourner à une vitesse périphérique jusqu'à 35 m/s.

La gamme proposée dans ce catalogue est la suivante:
POULIES TRAPEZOIDALES pour moyeu amovible, série ZT..... AT..... BT..... CT.....
POULIES TRAPEZOIDALES à moyeu plein, série ZM..... AM..... BM..... CM.....
POULIES TRAPEZOIDALES pour à moyeu de serrage.

Las poleas para correas trapezoidales presentadas por la Megadyne en el presente catálogo están todas construidas según las tablas ISO 4183 y DIN 2211-3.

El material empleado en la construcción de las mismas es el hierro fundido EN-GJL-200 UNI EN 1561 y después de las elaboraciones mecánicas están sometidas a un tratamiento superficial de FOSFATACIÓN.

Todas las poleas están equilibradas ESTÁTICAMENTE y son adecuadas para un funcionamiento de una velocidad de hasta 35 m/s.

La gama propuesta en el siguiente catálogo comprende:
POLEAS TRAPEZOIDALES para casquillos cónicos, serie ZT..... AT..... BT..... CT.....
POLEAS TRAPEZOIDALES con cubo pleno, serie ZM..... AM..... BM..... CM.....
POLEAS TRAPEZOIDALES para casquillos de fijación.

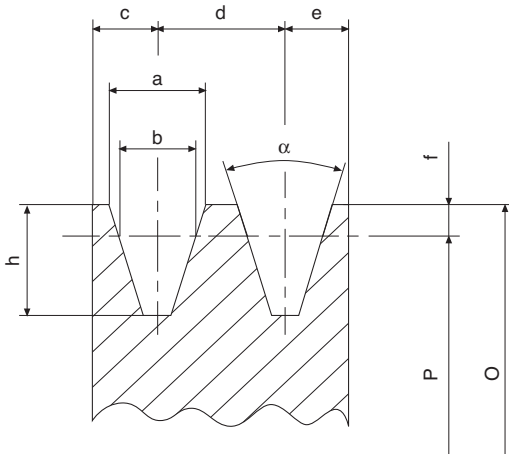

Calcolo della velocità periferica Vp in m/s
Calculation of peripheral speed Vp in m/s
Berechnung der Umfangsgeschwindigkeit Vp in m/s
Calcul de la vitesse périphérique Vp m/s
Cálculo de la velocidad periférica Vp en m/s

$$V_p = \frac{p \cdot P \cdot \text{rpm}}{60 \cdot 1000} @ \frac{P \cdot \text{rpm}}{19100} \quad V_p \leq 35 \text{ m/s}$$

P = Diametro primitivo in mm
 Pitch diameter in mm
 Teildurchmesser in mm
 Diamètre primitif en mm
 Diámetro primitivo en mm

rpm = Giri al minuto
 Revolutions per minute
 Umdrehungen pro Minute
 Tours par minute
 Revoluciones por minuto

Dimensioni puleggia	Pulley dimintions		Keilriemenscheibenabmessungen			Dimensions poulie		Dimensiones polea	
	a	b	c	d	e	f	h	34°	38°
SPZ	9,7	8,5	8,0	12,0	8,0	2,0	11,0	P <= 80	P > 80
SPA	12,7	11,0	10,0	15,0	10,0	2,8	13,8	P <= 118	P > 118
SPB	16,3	14,0	12,5	19,0	12,5	3,5	17,5	P <= 190	P > 190
SPC	22,0	19,0	17,0	25,5	17,0	4,8	23,8	P <= 315	P > 315

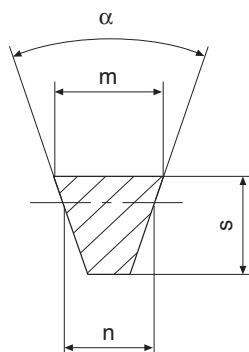

Dimensioni cinghia / Belt dimintions / Riemenabmessungen Dimensions courroie / Dimensiones correa

	m	s	n
SPZ	9,7	8	8,5
SPA	12,7	10	11,0
SPB	16,3	13	14,0
SPC	22,0	18	19,0

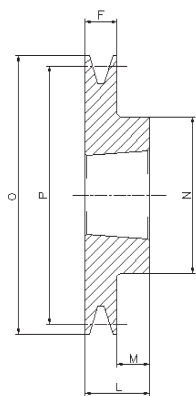

1

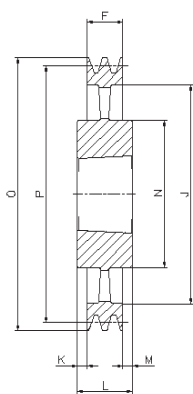

4

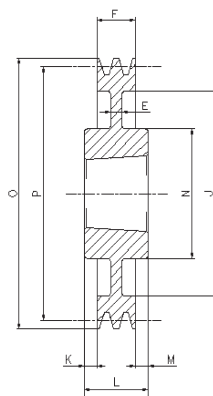

7

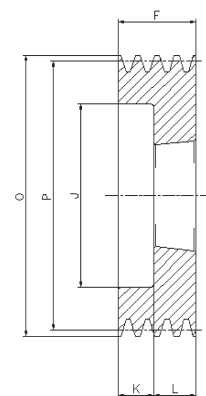

9

SPZ/1

Descrizione Description Beschreibung Description Descripción	Gole Grooves Rillen Gorges Canales	P	O	Forma Form Forme Forme Forma	Bussola Bush Buchse Moyeu Casquillo	∅ MAX	E	F	J	K	L	M	N
SPZ 50-01	1	50	54	9	1008	25	-	37	26	12,0	25	-	-
SPZ 56-01	1	56	60	9	1008	25	-	37	32	12,0	25	-	-
SPZ 60-01	1	60	64	1	1008	25	-	22	-	-	22	-	-
SPZ 63-01	1	63	67	1	1108	28	-	16	-	-	22	6,0	56
SPZ 67-01	1	67	71	1	1108	28	-	16	-	-	22	6,0	60
SPZ 71-01	1	71	75	1	1108	28	-	16	-	-	22	6,0	60
SPZ 75-01	1	75	79	1	1108	28	-	16	-	-	22	6,0	60
SPZ 80-01	1	80	84	1	1210	32	-	16	-	-	25	9,0	75
SPZ 85-01	1	85	89	1	1210	32	-	16	-	-	25	9,0	80
SPZ 90-01	1	90	94	1	1210	32	-	16	-	-	25	9,0	80
SPZ 95-01	1	95	99	1	1210	32	-	16	-	-	25	9,0	85
SPZ100-01	1	100	104	1	1210	32	-	16	-	-	25	9,0	85
SPZ106-01	1	106	110	1	1610	42	-	16	-	-	25	9,0	92
SPZ112-01	1	112	116	1	1610	42	-	16	-	-	25	9,0	92
SPZ118-01	1	118	122	1	1610	42	-	16	-	-	25	9,0	92
SPZ125-01	1	125	129	1	1610	42	-	16	-	-	25	9,0	92
SPZ132-01	1	132	136	1	1610	42	-	16	-	-	25	9,0	92
SPZ140-01	1	140	144	1	1610	42	-	16	-	-	25	9,0	92
SPZ150-01	1	150	154	1	1610	42	-	16	-	-	25	9,0	92
SPZ160-01	1	160	164	1	1610	42	-	16	-	-	25	9,0	92
SPZ170-01	1	170	174	1	1610	42	-	16	-	-	25	9,0	92
SPZ180-01	1	180	184	7	1610	42	6	16	152	-	25	9,0	92
SPZ190-01	1	190	194	7	1610	42	12	16	162	-	25	9,0	92
SPZ200-01	1	200	204	7	2012	50	10	16	171	-	32	16,0	112
SPZ224-01	1	224	228	7	2012	50	15	16	195	-	32	16,0	112
SPZ250-01	1	250	254	4	2012	50	-	16	221	8,0	32	8,0	112
SPZ280-01	1	280	284	4	2012	50	-	16	251	8,0	32	8,0	112
SPZ315-01	1	315	319	4	2012	50	-	16	286	8,0	32	8,0	112
SPZ355-01	1	355	359	4	2012	50	-	16	326	8,0	32	8,0	112
SPZ400-01	1	400	404	4	2012	50	-	16	371	8,0	32	8,0	112
SPZ450-01	1	450	454	4	2517	60	-	16	421	14,5	45	14,5	124

FORMA FORM

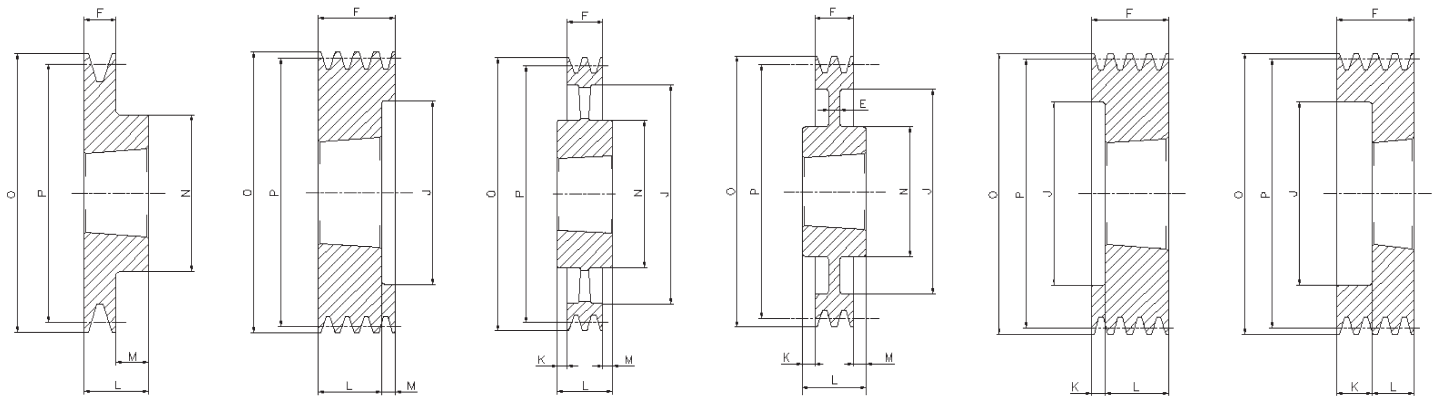

1

2

4

7

8

9

SPZ/2

Descrizione Description Beschreibung Description Descripción	Gole Grooves Rillen Gorges Canales	P	O	Forma Forme Forme Forme Forma	Bussola Bush Buchse Moyeu Casquillo	∅ MAX	E	F	J	K	L	M	N
SPZ 50-02	2	50	54	9	1008	25	-	50	26	25,0	25	-	-
SPZ 56-02	2	56	60	9	1008	25	-	49	32	27,0	22	-	-
SPZ 60-02	2	60	64	9	1108	28	-	49	36	27,0	22	-	-
SPZ 63-02	2	63	67	8	1108	28	-	28	40	6,0	22	-	-
SPZ 67-02	2	67	71	8	1108	28	-	28	42	6,0	22	-	-
SPZ 71-02	2	71	75	8	1108	28	-	28	42	6,0	22	-	-
SPZ 75-02	2	75	79	8	1210	32	-	28	51	3,0	25	-	-
SPZ 80-02	2	80	84	8	1210	32	-	28	51	3,0	25	-	-
SPZ 85-02	2	85	89	8	1610	42	-	28	60	3,0	25	-	-
SPZ 90-02	2	90	94	8	1610	42	-	28	61	3,0	25	-	-
SPZ 95-02	2	95	99	8	1610	42	-	28	66	3,0	25	-	-
SPZ100-02	2	100	104	8	1610	42	-	28	71	3,0	25	-	-
SPZ106-02	2	106	110	8	1610	42	-	28	76	3,0	25	-	-
SPZ112-02	2	112	116	8	1610	42	-	28	83	3,0	25	-	-
SPZ118-02	2	118	122	8	1610	42	-	28	90	3,0	25	-	-
SPZ125-02	2	125	129	8	1610	42	-	28	96	3,0	25	-	-
SPZ132-02	2	132	136	8	1610	42	-	28	103	3,0	25	-	-
SPZ140-02	2	140	144	8	1610	42	-	28	111	3,0	25	-	-
SPZ150-02	2	150	154	1	2012	50	-	28	-	-	32	4,0	112
SPZ160-02	2	160	164	1	2012	50	-	28	-	-	32	4,0	112
SPZ170-02	2	170	174	1	2012	50	-	28	-	-	32	4,0	112
SPZ180-02	2	180	184	7	2012	50	6	28	152	-	32	4,0	112
SPZ190-02	2	190	194	7	2012	50	12	28	162	-	32	4,0	112
SPZ200-02	2	200	204	7	2012	50	6	28	171	-	32	4,0	112
SPZ224-02	2	224	228	4	2012	50	15	28	195	-	32	4,0	112
SPZ250-02	2	250	254	4	2012	50	-	28	221	2,0	32	2,0	112
SPZ280-02	2	280	284	4	2012	50	-	28	251	2,0	32	2,0	112
SPZ315-02	2	315	319	4	2012	50	-	28	286	2,0	32	2,0	112
SPZ355-02	2	355	359	4	2012	50	-	28	326	2,0	32	2,0	112
SPZ400-02	2	400	404	4	2517	60	-	28	371	8,5	45	8,5	124
SPZ450-02	2	450	454	4	2517	60	-	28	421	8,5	45	8,5	124
SPZ500-02	2	500	504	4	2517	60	-	28	471	8,5	45	8,5	124

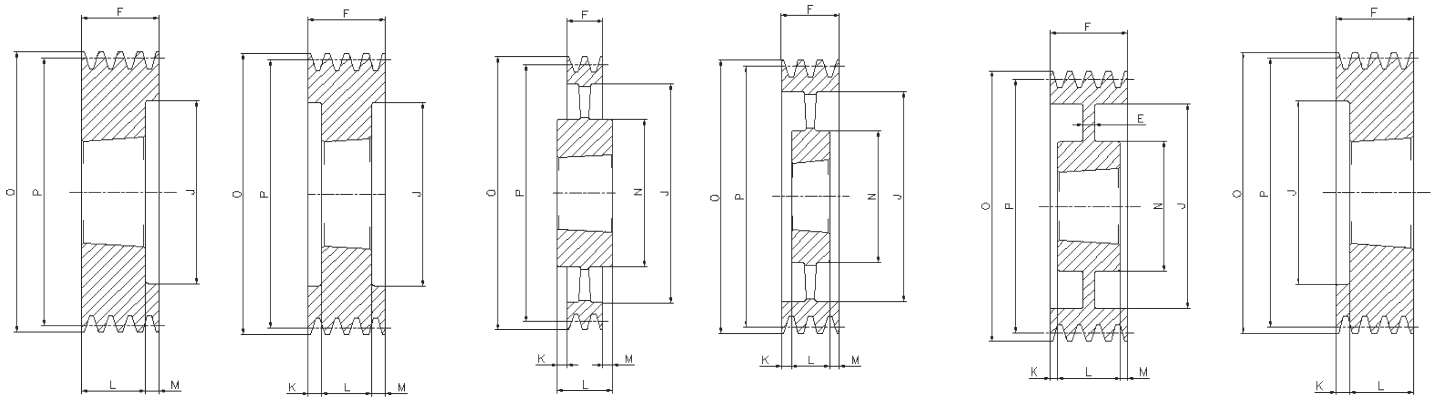

2

3

4

5

6

8

SPZ/3

Descrizione Description Beschreibung Description Descripción	Gole Grooves Rillen Gorges Canales	P	O	Forma Form Forme Forme Forma	Bussola Bush Buchse Moyeu Casquillo	Ø MAX	E	F	J	K	L	M	N
SPZ63-03	3	63	67	8	1108	28	-	40	40	-	22	-	-
SPZ67-03	3	67	71	8	1108	28	-	40	42	18,0	22	-	-
SPZ71-03	3	71	75	8	1108	28	-	40	42	18,0	22	-	-
SPZ75-03	3	75	79	8	1210	32	-	40	51	15,0	25	-	-
SPZ80-03	3	80	84	8	1210	32	-	40	51	15,0	25	-	-
SPZ85-03	3	85	89	8	1610	42	-	40	60	15,0	25	-	-
SPZ90-03	3	90	94	8	1610	42	-	40	61	15,0	25	-	-
SPZ95-03	3	95	99	8	1610	42	-	40	66	15,0	25	-	-
SPZ100-03	3	100	104	8	1610	42	-	40	71	15,0	25	-	-
SPZ106-03	3	106	110	8	1610	42	-	40	76	15,0	25	-	-
SPZ112-03	3	112	116	8	2012	50	-	40	83	8,0	32	-	-
SPZ118-03	3	118	122	8	2012	50	-	40	90	8,0	32	-	-
SPZ125-03	3	125	129	2	2012	50	-	40	96	-	32	8,0	-
SPZ132-03	3	132	136	2	2012	50	-	40	103	-	32	8,0	-
SPZ140-03	3	140	144	2	2012	50	-	40	111	-	32	8,0	-
SPZ150-03	3	150	154	2	2012	50	-	40	121	-	32	8,0	-
SPZ160-03	3	160	164	2	2012	50	-	40	131	-	32	8,0	-
SPZ170-03	3	170	174	3	2012	50	-	40	141	4,0	32	4,0	-
SPZ180-03	3	180	184	6	2012	50	7	40	151	-	32	8,0	106
SPZ190-03	3	190	194	6	2012	50	10	40	161	4,0	32	4,0	112
SPZ200-03	3	200	204	6	2012	50	10	40	171	4,0	32	4,0	112
SPZ224-03	3	224	228	6	2012	50	12	40	195	4,0	32	4,0	112
SPZ250-03	3	250	254	5	2012	50	-	40	221	4,0	32	4,0	112
SPZ280-03	3	280	284	4	2517	60	-	40	251	2,5	45	2,5	124
SPZ315-03	3	315	319	4	2517	60	-	40	286	2,5	45	2,5	124
SPZ355-03	3	355	359	4	2517	60	-	40	326	2,5	45	2,5	124
SPZ400-03	3	400	404	4	2517	60	-	40	371	2,5	45	2,5	124
SPZ450-03	3	450	454	4	2517	60	-	40	421	2,5	45	2,5	124
SPZ500-03	3	500	504	4	2517	60	-	40	471	2,5	45	2,5	124
SPZ630-03	3	630	634	4	3020	75	-	40	601	5,5	51	5,5	150
SPZ800-03	3	800	804	4	3020	75	-	40	771	5,5	51	5,5	146

FORMA FORM

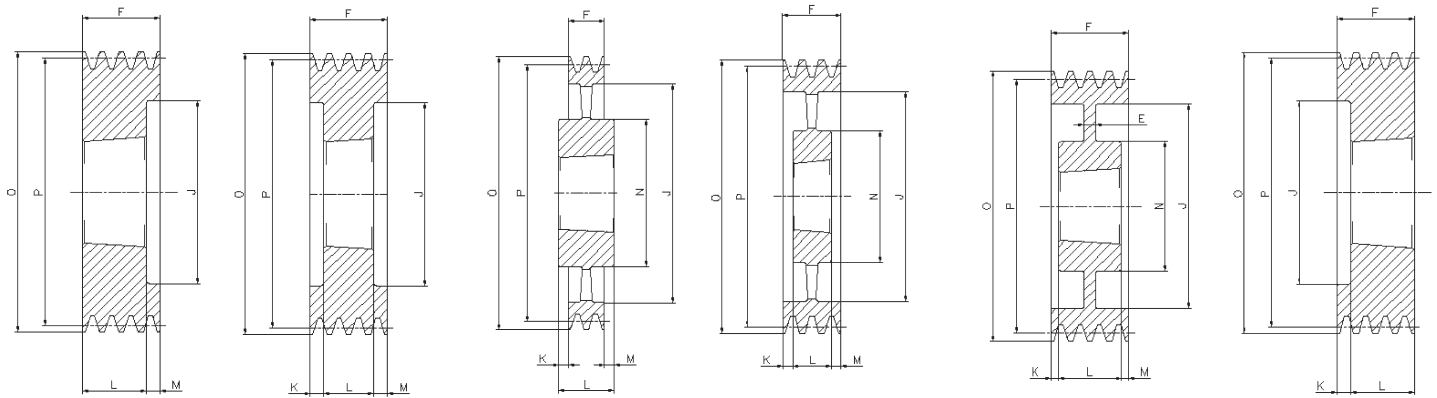

2

3

4

5

6

8

SPZ/4

Descrizione Description Beschreibung Description Descripción	Gole Grooves Rillen Gorges Canales	P	O	Forma Form Forme Forme Forma	Bussola Bush Buchse Moyeu Casquillo	ø MAX	E	F	J	K	L	M	N
SPZ 80-04	4	80	84	8	1210	32	-	52	51	27,0	25	-	-
SPZ 85-04	4	85	89	8	1610	42	-	52	60	27,0	25	-	-
SPZ 90-04	4	90	94	8	1610	42	-	52	61	27,0	25	-	-
SPZ 95-04	4	95	99	8	1610	42	-	52	66	27,0	25	-	-
SPZ100-04	4	100	104	8	1610	42	-	52	71	27,0	25	-	-
SPZ106-04	4	106	110	8	1610	42	-	52	76	27,0	25	-	-
SPZ112-04	4	112	116	8	2012	50	-	52	83	20,0	32	-	-
SPZ118-04	4	118	122	8	2012	50	-	52	90	20,0	32	-	-
SPZ125-04	4	125	129	2	2012	50	-	52	96	-	32	20,0	-
SPZ132-04	4	132	136	2	2012	50	-	52	103	-	32	20,0	-
SPZ140-04	4	140	144	2	2012	50	-	52	111	-	32	20,0	-
SPZ150-04	4	150	154	2	2517	60	-	52	121	-	45	7,0	-
SPZ160-04	4	160	164	2	2517	60	-	52	131	-	45	7,0	-
SPZ170-04	4	170	174	2	2517	60	-	52	141	-	45	7,0	-
SPZ180-04	4	180	184	2	2517	60	-	52	151	-	45	7,0	-
SPZ190-04	4	190	194	3	2517	60	-	52	161	3,5	45	3,5	-
SPZ200-04	4	200	204	6	2517	60	8	52	171	3,5	45	3,5	124
SPZ224-04	4	224	228	6	2517	60	14	52	195	3,5	45	3,5	124
SPZ250-04	4	250	254	6	2517	60	12	52	221	3,5	45	3,5	124
SPZ280-04	4	280	284	6	2517	60	14	52	251	3,5	45	3,5	124
SPZ315-04	4	315	319	5	2517	60	-	52	286	3,5	45	3,5	124
SPZ355-04	4	355	359	5	2517	60	-	52	326	3,5	45	3,5	124
SPZ400-04	4	400	404	5	2517	60	-	52	371	3,5	45	3,5	124
SPZ450-04	4	450	454	5	3020	75	-	52	421	0,5	51	0,5	146
SPZ500-04	4	500	504	5	3020	75	-	52	471	0,5	51	0,5	146
SPZ630-04	4	630	634	4	3030	75	-	52	601	12,0	76	12,0	146
SPZ800-04	4	800	804	4	3030	75	-	52	771	12,0	76	12,0	146

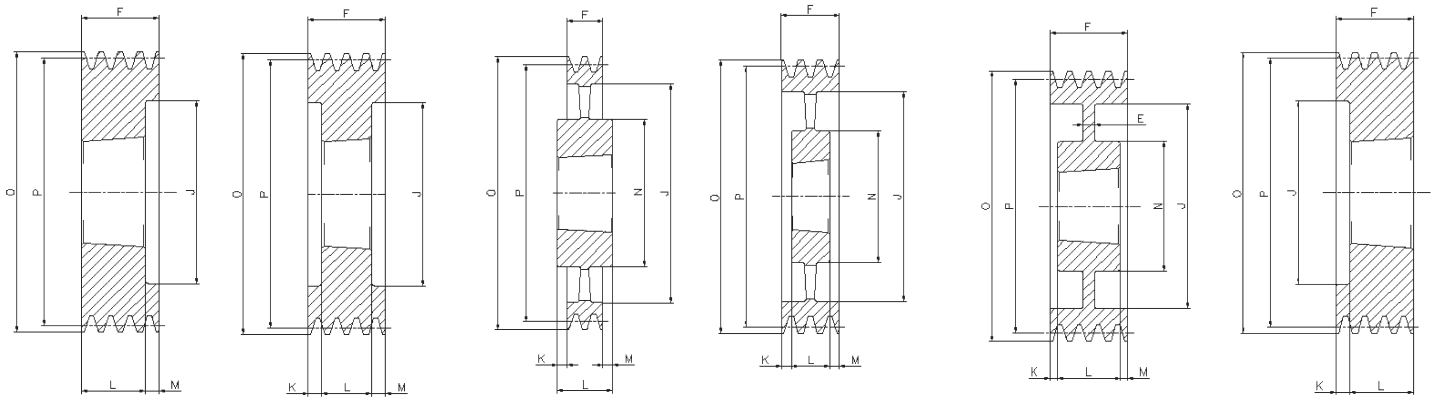

2

3

4

5

6

8

SPZ/5

Descrizione Description Beschreibung Description Descripción	Gole Grooves Rillen Gorges Canales	P	O	Forma Forme Forme Forme Forma	Bussola Bush Buchse Moyeu Casquillo	∅ MAX	E	F	J	K	L	M	N
SPZ 85-05	5	85	89	8	1610	42	-	64	60	39,0	25	-	-
SPZ 90-05	5	90	94	8	1610	42	-	64	61	39,0	25	-	-
SPZ 95-05	5	95	99	8	1610	42	-	64	66	39,0	25	-	-
SPZ100-05	5	100	104	8	2012	50	-	64	71	32,0	32	-	-
SPZ106-05	5	106	110	8	2012	50	-	64	76	32,0	32	-	-
SPZ112-05	5	112	116	8	2012	50	-	64	83	32,0	32	-	-
SPZ118-05	5	118	122	8	2012	50	-	64	90	32,0	32	-	-
SPZ125-05	5	125	129	8	2012	50	-	64	96	32,0	32	-	-
SPZ132-05	5	132	136	8	2517	60	-	64	103	19,0	45	19,0	-
SPZ140-05	5	140	144	2	2517	60	-	64	111	-	45	19,0	-
SPZ150-05	5	150	154	2	2517	60	-	64	121	-	45	19,0	-
SPZ160-05	5	160	164	2	2517	60	-	64	131	-	45	19,0	-
SPZ170-05	5	170	174	2	2517	60	-	64	141	-	45	19,0	-
SPZ180-05	5	180	184	2	2517	60	-	64	151	-	45	19,0	-
SPZ190-05	5	190	194	3	2517	60	-	64	161	9,5	45	9,5	-
SPZ200-05	5	200	204	3	2517	60	-	64	171	9,5	45	9,5	-
SPZ224-05	5	224	228	6	2517	60	20	64	195	9,5	45	9,5	124
SPZ250-05	5	250	254	6	2517	60	16	64	221	9,5	45	9,5	124
SPZ280-05	5	280	284	6	2517	60	15	64	251	9,5	45	9,5	124
SPZ315-05	5	315	319	5	2517	60	-	64	286	9,5	45	9,5	124
SPZ355-05	5	355	359	5	2517	60	-	64	326	9,5	45	9,5	124
SPZ400-05	5	400	404	5	3020	75	-	64	371	6,5	51	6,5	146
SPZ450-05	5	450	454	5	3020	75	-	64	421	6,5	51	6,5	146
SPZ500-05	5	500	504	4	3030	75	-	64	471	6,0	76	6,0	146
SPZ630-05	5	630	634	4	3030	75	-	64	601	6,0	76	6,0	146
SPZ800-05	5	800	804	4	3535	90	-	64	771	12,5	89	12,5	178

FORMA FORM

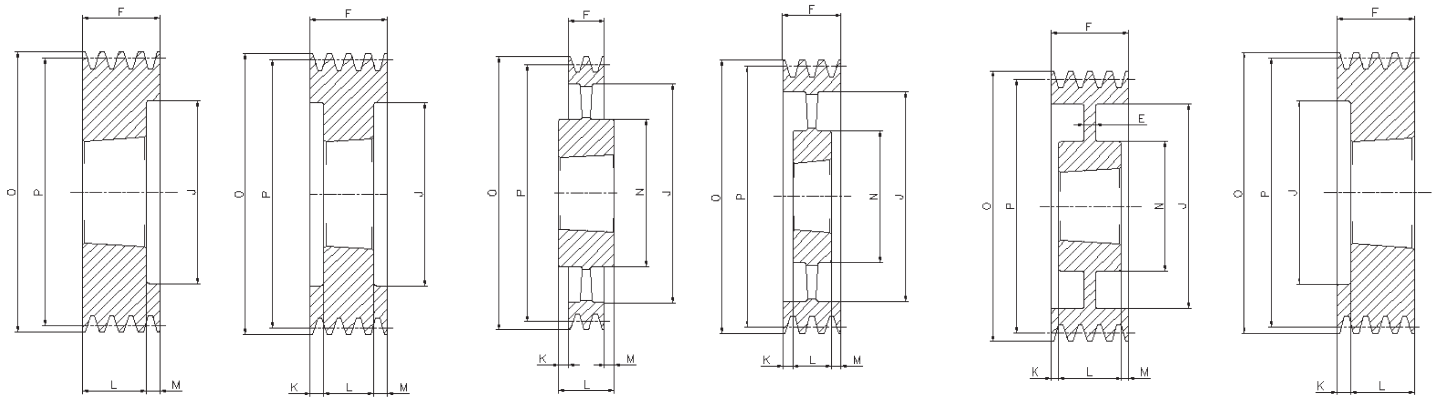

2

3

4

5

6

8

SPZ/6

Descrizione Description Beschreibung Description Descripción	Gole Grooves Rillen Gorges Canales	P	O	Forma Form Forme Forme Forma	Bussola Bush Buchse Moyeu Casquillo	ø MAX	E	F	J	K	L	M	N
SPZ 90-06	6	90	94	8	1610	42	-	76	61	51,0	25	-	-
SPZ 95-06	6	95	99	8	1610	42	-	76	66	51,0	25	-	-
SPZ100-06	6	100	104	8	2012	50	-	76	71	44,0	32	-	-
SPZ106-06	6	106	110	8	2012	50	-	76	76	44,0	32	-	-
SPZ112-06	6	112	116	8	2012	50	-	76	83	44,0	32	-	-
SPZ118-06	6	118	122	8	2517	60	-	76	90	31,0	45	-	-
SPZ125-06	6	125	129	8	2517	60	-	76	96	31,0	45	-	-
SPZ132-06	6	132	136	8	2517	60	-	76	103	31,0	45	-	-
SPZ140-06	6	140	144	2	2517	60	-	76	111	-	45	31,0	-
SPZ150-06	6	150	154	2	2517	60	-	76	121	-	45	31,0	-
SPZ160-06	6	160	164	2	2517	60	-	76	131	-	45	31,0	-
SPZ170-06	6	170	174	2	2517	60	-	76	141	-	45	31,0	-
SPZ180-06	6	180	184	3	2517	60	-	76	151	15,5	45	15,5	-
SPZ190-06	6	190	194	3	2517	60	-	76	161	15,5	45	15,5	124
SPZ200-06	6	200	204	3	2517	60	-	76	171	15,5	45	15,5	124
SPZ224-06	6	224	228	6	2517	60	26	76	195	15,5	45	15,5	124
SPZ250-06	6	250	254	6	2517	60	26	76	221	15,5	45	15,5	124
SPZ280-06	6	280	284	6	2517	60	15	76	251	15,5	45	15,5	124
SPZ315-06	6	315	319	6	2517	60	15	76	286	15,5	45	15,5	124
SPZ355-06	6	355	359	5	2517	60	-	76	326	15,5	45	15,5	124
SPZ400-06	6	400	404	5	3030	75	-	76	371	-	76	-	146
SPZ450-06	6	450	454	5	3030	75	-	76	421	-	76	-	146
SPZ500-06	6	500	504	5	3030	75	-	76	471	-	76	-	146
SPZ630-06	6	630	634	4	3535	90	-	76	601	6,5	89	6,5	175
SPZ800-06	6	800	804	4	3535	90	-	76	771	6,5	89	6,5	178

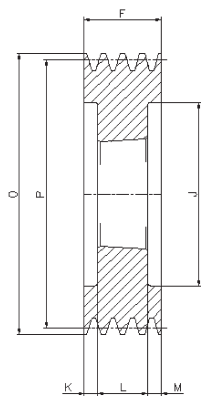

3

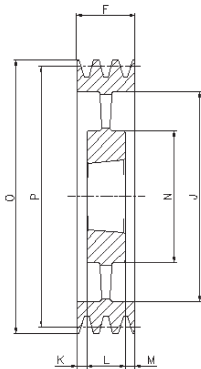

5

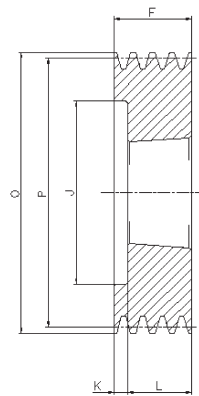

8

SPZ/8

Descrizione Description Beschreibung Description Descripción	Gole Grooves Rillen Gorges Canales	P	O	Forma Form Forme Forme Forma	Bussola Bush Buchse Moyeu Casquillo	∅ MAX	E	F	J	K	L	M	N
SPZ140-08	8	140	144	3	2517	60	-	100	111	27,5	45	27,5	-
SPZ150-08	8	150	154	3	2517	60	-	100	121	27,5	45	27,5	-
SPZ160-08	8	160	164	3	2517	60	-	100	131	27,5	45	27,5	-
SPZ180-08	8	180	184	3	2517	60	-	100	151	27,5	45	27,5	-
SPZ200-08	8	200	204	3	3020	75	-	100	171	24,5	51	24,5	-
SPZ224-08	8	224	228	3	3020	75	-	100	195	24,5	51	24,5	-
SPZ250-08	8	250	254	6	3020	75	20	100	221	24,5	51	24,5	146
SPZ280-08	8	280	284	6	3020	75	20	100	251	24,5	51	24,5	146
SPZ355-08	8	355	359	5	3030	75	-	100	326	12,5	76	12,5	146
SPZ400-08	8	400	404	5	3030	75	-	100	371	12,5	76	12,5	146
SPZ450-08	8	450	454	5	3535	pp90	-	100	421	5,5	89	5,5	175

FORMA FORM

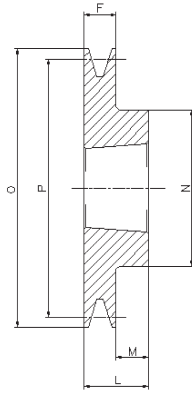

1

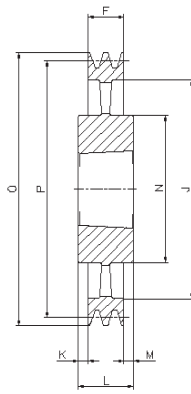

4

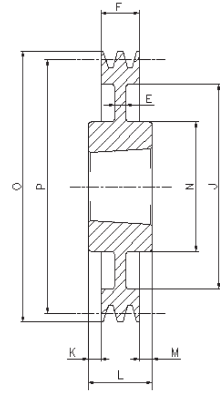

7

SPA/1

Descrizione Description Beschreibung Description Descripción	Gole Grooves Rillen Gorges Canales	P	O	Forma Form Forme Forme Forma	Bussola Bush Buchse Moyeu Casquillo	ø MAX	E	F	J	K	L	M	N
SPA 63-01	1	63	68,5	1	1008	25	-	20	-	-	22	2	56
SPA 67-01	1	67	72,5	1	1108	28	-	20	-	-	22	2	56
SPA 71-01	1	71	76,5	1	1108	28	-	20	-	-	22	2	60
SPA 75-01	1	75	80,5	1	1108	28	-	20	-	-	22	2	56
SPA 80-01	1	80	85,5	1	1210	32	-	20	-	-	25	5	75
SPA 85-01	1	85	90,5	1	1210	32	-	20	-	-	25	5	80
SPA 90-01	1	90	95,5	1	1210	32	-	20	-	-	25	5	80
SPA 95-01	1	95	100,5	1	1210	32	-	20	-	-	25	5	85
SPA100-01	1	100	105,5	1	1610	42	-	20	-	-	25	5	85
SPA106-01	1	106	111,5	1	1610	42	-	20	-	-	25	5	92
SPA112-01	1	112	117,5	1	1610	42	-	20	-	-	25	5	92
SPA118-01	1	118	123,5	1	1610	42	-	20	-	-	25	5	92
SPA125-01	1	125	130,5	1	1610	42	-	20	-	-	25	5	92
SPA132-01	1	132	137,5	1	1610	42	-	20	-	-	25	5	92
SPA140-01	1	140	145,5	1	1610	42	-	20	-	-	25	5	92
SPA150-01	1	150	155,5	1	1610	42	-	20	-	-	25	5	92
SPA160-01	1	160	165,5	1	1610	42	-	20	-	-	25	5	92
SPA170-01	1	170	175,5	1	1610	42	-	20	-	-	25	5	92
SPA180-01	1	180	185,5	7	1610	42	6	20	145	-	25	5	92
SPA190-01	1	190	195,5	7	1610	42	6	20	156	-	25	5	92
SPA200-01	1	200	205,5	7	2012	50	6	20	165	-	32	12	108
SPA212-01	1	212	217,5	7	2012	50	10	20	177	-	32	12	110
SPA224-01	1	224	229,5	7	2012	50	10	20	189	-	32	12	112
SPA236-01	1	236	241,5	7	2012	50	10	20	202	-	32	12	112
SPA250-01	1	250	255,5	7	2012	50	10	20	215	6	32	6	112
SPA280-01	1	280	285,5	7	2012	50	10	20	245	-	32	12	112
SPA300-01	1	300	305,5	7	2012	50	12	20	265	-	32	12	112
SPA315-01	1	315	320,5	7	2012	50	12	20	280	-	32	12	112
SPA355-01	1	355	360,5	4	2012	50	-	20	320	-	32	12	112
SPA400-01	1	400	405,5	4	2012	50	-	20	365	-	32	12	112
SPA450-01	1	450	455,5	4	2012	50	-	20	415	-	32	12	112
SPA500-01	1	500	505,5	4	2517	60	-	20	465	-	45	25	124
SPA630-01	1	630	635,5	4	2517	60	-	20	595	-	45	25	124

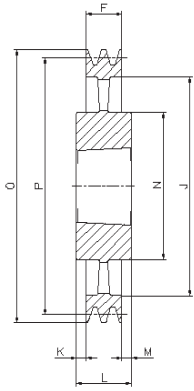

4

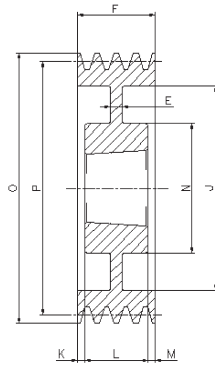

6

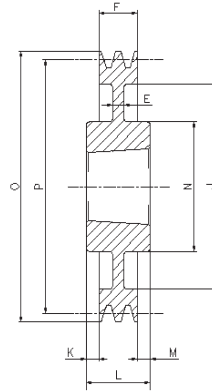

7

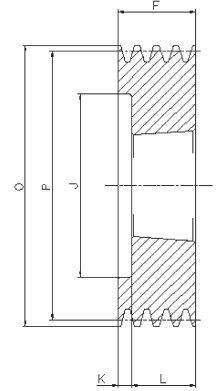

8

SPA/2

Descrizione Description Beschreibung Description Descripción	Gole Grooves Rillen Gorges Canales	P	O	Forma Form Forme Forme Forma	Bussola Bush Buchse Moyeu Casquillo	Ø MAX	E	F	J	K	L	M	N
SPA 63-02	2	63	68,5	8	1008	28	-	35	32,5	13,0	22	-	-
SPA 67-02	2	67	72,5	8	1108	28	-	35	37,0	13,0	22	-	-
SPA 71-02	2	71	76,5	8	1108	28	-	35	40,0	13,0	22	-	-
SPA 75-02	2	75	80,5	8	1108	28	-	35	44,0	13,0	22	-	-
SPA 80-02	2	80	85,5	8	1210	32	-	35	50,0	10,0	25	-	-
SPA 85-02	2	85	90,5	8	1210	32	-	35	55,0	10,0	25	-	-
SPA 90-02	2	90	95,5	8	1610	42	-	35	59,0	10,0	25	-	-
SPA 95-02	2	95	100,5	8	1610	42	-	35	63,0	10,0	25	-	-
SPA100-02	2	100	105,5	8	1610	42	-	35	66,0	10,0	25	-	-
SPA106-02	2	106	111,5	8	1610	42	-	35	72,0	10,0	25	-	-
SPA112-02	2	112	117,5	8	1610	42	-	35	78,0	10,0	25	-	-
SPA118-02	2	118	123,5	8	1610	42	-	35	84,0	10,0	25	-	-
SPA125-02	2	125	130,5	8	1610	42	-	35	91,0	10,0	25	-	-
SPA132-02	2	132	137,5	8	2012	50	-	35	98,0	3,0	32	-	-
SPA140-02	2	140	145,5	8	2012	50	-	35	106,0	3,0	32	-	-
SPA150-02	2	150	155,5	8	2012	50	-	35	116,0	3,0	32	-	-
SPA160-02	2	160	165,5	8	2012	50	-	35	125,0	3,0	32	-	-
SPA170-02	2	170	175,5	8	2012	50	-	35	135,0	3,0	32	-	-
SPA180-02	2	180	185,5	6	2012	50	10	35	146,0	1,5	32	1,5	108
SPA190-02	2	190	195,5	6	2012	50	10	35	156,0	1,5	32	1,5	108
SPA200-02	2	200	205,5	7	2517	60	10	35	165,0	5,0	45	5,0	123
SPA212-02	2	212	217,5	7	2517	60	18	35	177,0	5,0	45	5,0	123
SPA224-02	2	224	229,5	7	2517	60	18	35	189,0	-	45	10,0	124
SPA236-02	2	236	241,5	7	2517	60	12	35	202,0	-	45	10,0	124
SPA250-02	2	250	255,5	7	2517	60	12	35	215,0	5,0	45	5,0	124
SPA280-02	2	280	285,5	7	2517	60	12	35	245,0	-	45	10,0	124
SPA300-02	2	300	305,5	7	2517	60	12	35	265,0	-	45	10,0	124
SPA315-02	2	315	320,5	7	2517	60	12	35	280,0	-	45	10,0	124
SPA355-02	2	355	360,5	4	2517	60	-	35	320,0	-	45	10,0	124
SPA400-02	2	400	405,5	4	2517	60	-	35	365,0	-	45	10,0	124
SPA450-02	2	450	455,5	4	2517	60	-	35	465,0	-	45	10,0	124
SPA500-02	2	500	505,5	4	2517	60	-	35	525,0	-	45	10,0	125
SPA630-02	2	630	635,5	4	3020	75	-	35	595,0	8,0	51	18,0	159

FORMA FORM

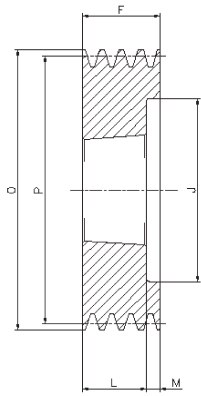

2

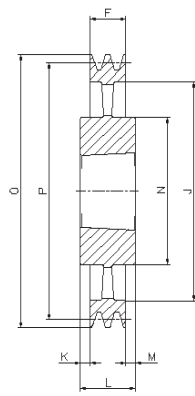

4

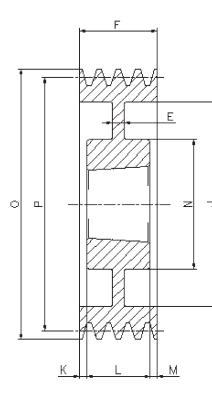

6

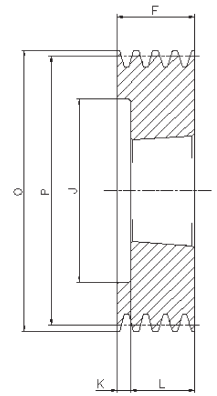

8

SPA/3

Descrizione Description Beschreibung Description Descripción	Gole Grooves Rillen Gorges Canales	P	O	Forma Form Forme Forma Forma	Bussola Bush Buchse Moyeu Casquillo	Ø MAX	E	F	J	K	L	M	N
SPA 71-03	3	71	76,5	8	1108	28	-	50	40	28,0	22	-	-
SPA 75-03	3	75	80,5	8	1108	28	-	50	44	28,0	22	-	-
SPA 80-03	3	80	85,5	8	1210	32	-	50	50	25,0	25	-	-
SPA 85-03	3	85	90,5	8	1210	32	-	50	55	25,0	25	-	-
SPA 90-03	3	90	95,5	8	1610	42	-	50	59	25,0	25	-	-
SPA 95-03	3	95	100,5	8	1610	42	-	50	63	25,0	25	-	-
SPA100-03	3	100	105,5	2	1610	42	-	50	66	-	25	25,0	-
SPA106-03	3	106	111,5	2	1610	42	-	50	72	-	25	25,0	-
SPA112-03	3	112	117,5	8	2012	50	-	50	78	18,0	32	-	-
SPA118-03	3	118	123,5	2	2012	50	-	50	84	-	32	18,0	-
SPA125-03	3	125	130,5	2	2012	50	-	50	91	-	32	18,0	-
SPA132-03	3	132	137,5	2	2012	50	-	50	98	-	32	18,0	-
SPA140-03	3	140	145,5	8	2517	60	-	50	106	5,0	45	-	-
SPA150-03	3	150	155,5	8	2517	60	-	50	116	5,0	45	-	-
SPA160-03	3	160	165,5	8	2517	60	-	50	125	5,0	45	-	-
SPA170-03	3	170	175,5	8	2517	60	-	50	135	5,0	45	-	-
SPA180-03	3	180	185,5	8	2517	60	-	50	146	5,0	45	-	-
SPA190-03	3	190	195,5	8	2517	60	-	50	156	5,0	45	-	-
SPA200-03	3	200	205,5	6	2517	60	20	50	165	2,5	45	2,5	123
SPA212-03	3	212	217,5	6	2517	60	20	50	177	2,5	45	2,5	123
SPA224-03	3	224	229,5	6	2517	60	20	50	189	2,5	45	2,5	124
SPA236-03	3	236	241,5	6	2517	60	20	50	202	2,5	45	2,5	124
SPA250-03	3	250	255,5	6	2517	60	20	50	215	2,5	45	2,5	124
SPA280-03	3	280	285,5	6	2517	60	20	50	245	2,5	45	2,5	124
SPA300-03	3	300	305,5	4	3020	75	-	50	265	0,5	51	0,5	146
SPA315-03	3	315	320,5	4	3020	75	-	50	280	0,5	51	0,5	159
SPA355-03	3	355	360,5	4	3020	75	-	50	320	0,5	51	0,5	159
SPA400-03	3	400	405,5	4	3020	75	-	50	365	-	51	1,0	159
SPA450-03	3	450	455,5	4	3020	75	-	50	415	-	51	1,0	159
SPA500-03	3	500	505,5	4	3020	75	-	50	465	-	51	1,0	159
SPA560-03	3	560	565,5	4	3020	75	-	50	525	-	51	1,0	150
SPA630-03	3	630	635,5	4	3020	75	-	50	595	-	51	1,0	150
SPA800-03	3	800	805,5	4	3535	90	-	50	765	19,5	89	19,5	175
SPA1000-03	3	1000	1005,5	4	3535	90	-	50	965	19,5	89	19,5	175

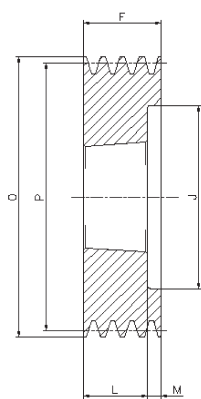
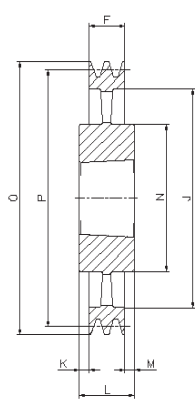
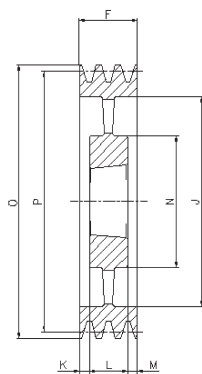
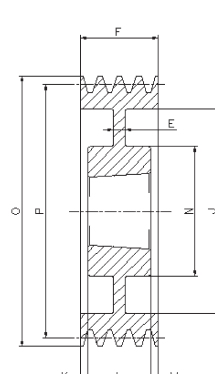
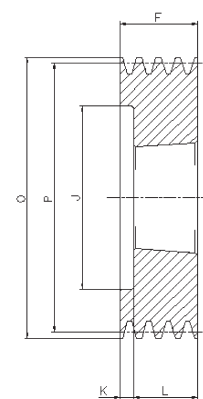
2

4

5

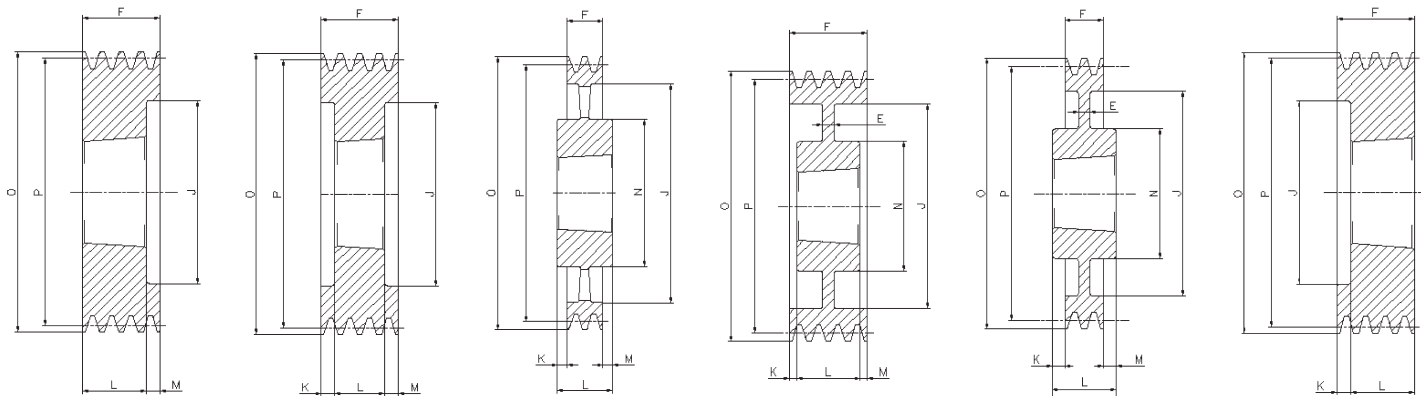
6

8
SPA/4

Descrizione Description Beschreibung Description Descripción	Gole Grooves Rillen Gorges Canales	P	O	Forma Form Forme Forme Forma	Bussola Bush Buchse Moyeu Casquillo	∅ MAX	E	F	J	K	L	M	N
SPA 80-04	4	80	85,5	8	1215	28	-	65	49	27	38	-	-
SPA 90-04	4	90	95,5	8	1615	42	-	65	59	27,0	38	-	-
SPA 95-04	4	95	100,5	8	1615	42	-	65	63	27,0	38	-	-
SPA100-04	4	100	105,5	2	1615	42	-	65	66	-	38	27,0	-
SPA106-04	4	106	111,5	8	2012	50	-	65	72	33,0	32	-	-
SPA112-04	4	112	117,5	8	2012	50	-	65	78	33,0	32	-	-
SPA118-04	4	118	123,5	2	2012	50	-	65	84	-	32	33,0	-
SPA125-04	4	125	130,5	2	2012	50	-	65	91	-	32	33,0	-
SPA132-04	4	132	137,5	2	2517	60	-	65	98	-	45	20,0	-
SPA140-04	4	140	145,5	2	2517	60	-	65	106	-	45	20,0	-
SPA150-04	4	150	155,5	2	2517	60	-	65	116	-	45	20,0	-
SPA160-04	4	160	165,5	2	2517	60	-	65	125	-	45	20,0	-
SPA170-04	4	170	175,5	2	2517	60	-	65	135	-	45	20,0	-
SPA180-04	4	180	185,5	2	2517	60	-	65	146	-	45	20,0	-
SPA190-04	4	190	195,5	2	2517	60	-	65	156	-	45	20,0	-
SPA200-04	4	200	205,5	2	3020	75	-	65	165	-	51	14,0	-
SPA212-04	4	212	217,5	2	3020	75	-	65	177	-	51	14,0	-
SPA224-04	4	224	229,5	2	3020	75	-	65	189	-	51	14,0	-
SPA236-04	4	236	241,5	6	3020	75	25	65	202	-	51	14,0	-
SPA250-04	4	250	255,5	6	3020	75	20	65	215	7,0	51	7,0	159
SPA280-04	4	280	285,5	6	3020	75	25	65	245	7,0	51	7,0	159
SPA300-04	4	300	305,5	6	3020	75	25	65	265	7,0	51	7,0	159
SPA315-04	4	315	320,5	6	3020	75	25	65	280	7,0	51	7,0	159
SPA355-04	4	355	360,5	5	3020	75	-	65	320	7,0	51	7,0	159
SPA400-04	4	400	405,5	5	3020	75	-	65	365	7,0	51	7,0	159
SPA450-04	4	450	455,5	5	3020	75	-	65	415	7,0	51	7,0	159
SPA500-04	4	500	505,5	5	3020	75	-	65	465	7,0	51	7,0	159
SPA560-04	4	560	565,5	4	3535	90	-	65	525	12,0	89	12,0	175
SPA630-04	4	630	635,5	4	3535	90	-	65	595	12,0	89	12,0	175
SPA800-04	4	800	805,5	4	3535	90	-	65	765	12,0	89	12,0	175
SPA1000-04	4	1000	1005,5	4	4040	100	-	65	965	18,5	102	18,5	210

FORMA FORM



2

3

4

6

7

8

SPA/5

Descrizione Description Beschreibung Description Descripción	Gole Grooves Rillen Gorges Canales	P	O	Forma Form Forme Forma Forma	Bussola Bush Buchse Moyeu Casquillo	Ø MAX	E	F	J	K	L	M	N
SPA100-05	5	100	105,5	2	1615	42	-	80	66	-	38	42,0	-
SPA106-05	5	106	111,5	8	2012	50	-	80	72	48,0	32	-	-
SPA112-05	5	112	117,5	8	2012	50	-	80	78	48,0	32	-	-
SPA118-05	5	118	123,5	2	2012	50	-	80	84	-	32	48,0	-
SPA125-05	5	125	130,5	3	2012	50	-	80	91	24,0	32	24,0	-
SPA132-05	5	132	137,5	3	2517	60	-	80	98	17,5	45	17,5	-
SPA140-05	5	140	145,5	3	2517	60	-	80	106	17,5	45	17,5	-
SPA150-05	5	150	155,5	3	2517	60	-	80	116	17,5	45	17,5	-
SPA160-05	5	160	165,5	3	2517	60	-	80	125	17,5	45	17,5	-
SPA170-05	5	170	175,5	3	2517	60	-	80	135	17,5	45	17,5	-
SPA180-05	5	180	185,5	3	3020	75	-	80	146	-	51	29,0	-
SPA190-05	5	190	195,5	2	3020	75	-	80	156	14,5	51	14,5	-
SPA200-05	5	200	205,5	3	3020	75	-	80	165	14,5	51	14,5	-
SPA212-05	5	212	217,5	2	3020	75	-	80	177	-	51	29,0	-
SPA224-05	5	224	229,5	2	3020	75	-	80	189	-	51	29,0	-
SPA236-05	5	236	241,5	2	3020	75	-	80	202	-	51	29,0	-
SPA250-05	5	250	255,5	6	3020	75	20	80	215	14,5	51	14,5	159
SPA280-05	5	280	285,5	7	3535	90	25	80	245	4,5	89	4,5	175
SPA300-05	5	300	305,5	7	3535	90	25	80	265	4,5	89	4,5	175
SPA315-05	5	315	320,5	7	3535	90	25	80	280	4,5	89	4,5	175
SPA355-05	5	355	360,5	4	3535	90	-	80	320	4,5	89	4,5	175
SPA400-05	5	400	405,5	4	3535	90	-	80	365	4,5	89	4,5	175
SPA450-05	5	450	455,5	4	3535	90	-	80	415	4,5	89	4,5	175
SPA500-05	5	500	505,5	4	3535	90	-	80	465	4,5	89	4,5	175
SPA560-05	5	560	565,5	4	3535	90	-	80	525	4,5	89	4,5	175
SPA630-05	5	630	635,5	4	3535	90	-	80	595	4,5	89	4,5	175
SPA800-05	5	800	805,5	4	4040	100	-	80	765	11,0	102	11,0	210
SPA1000-05	5	1000	1005,5	4	4545	110	-	80	965	17,0	114	17,0	242

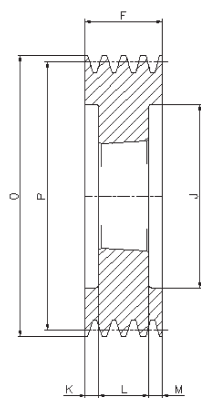
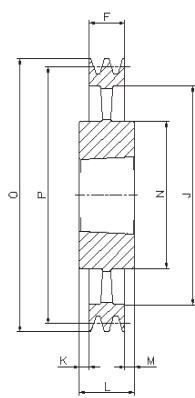
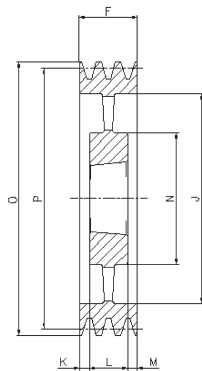
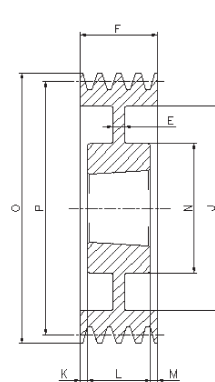
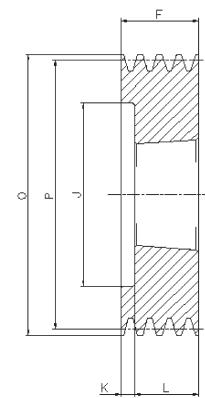

3

4

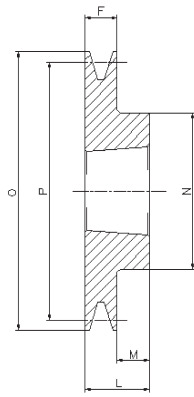
5

6

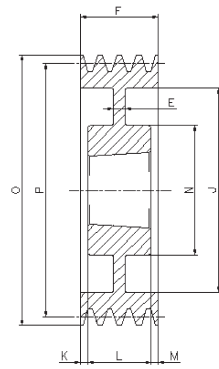
8
SPA/6

Descrizione Description Beschreibung Descripción	Gole Grooves Fillen Gorges Canales	P	O	Forma Form Forme Forme Forma	Bussola Bush Buchse Moyeu Casquillo	∅ MAX	E	F	J	K	L	M	N
SPA100-06	6	100	105,5	3	1610	42	-	95	66	30,0	25	40,0	-
SPA106-06	6	106	111,5	8	2012	50	-	95	72	63,0	32	-	-
SPA112-06	6	112	117,5	8	2012	50	-	95	78	63,0	32	-	-
SPA118-06	6	118	123,5	8	2012	50	-	95	84	63,0	32	-	-
SPA125-06	6	125	130,5	3	2012	50	-	95	91	31,5	32	31,5	-
SPA132-06	6	132	137,5	3	2517	60	-	95	98	25,0	45	25,0	-
SPA140-06	6	140	145,5	3	2517	60	-	95	106	25,0	45	25,0	-
SPA150-06	6	150	155,5	3	2517	60	-	95	116	25,0	45	25,0	-
SPA160-06	6	160	165,5	3	2517	60	-	95	125	25,0	45	25,0	-
SPA180-06	6	180	185,5	3	3020	75	-	95	146	22,0	51	22,0	-
SPA200-06	6	200	205,5	3	3020	75	-	95	165	22,0	51	22,0	-
SPA212-06	6	212	217,5	3	3020	75	-	95	176	22,0	51	22,0	-
SPA224-06	6	224	229,5	3	3020	75	-	95	189	22,0	51	22,0	-
SPA236-06	6	236	241,5	3	3020	75	-	95	202	22,0	51	22,0	-
SPA250-06	6	250	255,5	6	3020	75	20	95	215	22,0	51	22,0	155
SPA280-06	6	280	285,5	6	3535	90	25	95	245	3,0	89	3,0	175
SPA300-06	6	300	305,5	6	3535	90	25	95	265	3,0	89	3,0	175
SPA315-06	6	315	320,5	6	3535	90	25	95	280	3,0	89	3,0	175
SPA355-06	6	355	360,5	5	3535	90	-	95	320	3,0	89	3,0	175
SPA400-06	6	400	405,5	5	3535	90	-	95	365	3,0	89	3,0	175
SPA450-06	6	450	455,5	5	3535	90	-	95	415	3,0	89	3,0	175
SPA500-06	6	500	505,5	5	3535	90	-	95	465	3,0	89	3,0	175
SPA560-06	6	560	565,5	5	3535	90	-	95	525	3,0	89	3,0	175
SPA630-06	6	630	635,5	4	4040	100	-	95	595	3,5	102	3,5	210
SPA800-06	6	800	805,5	4	4040	100	-	95	765	3,5	102	3,5	210
SPA1000-06	6	1000	1005,5	4	4545	110	-	95	965	9,5	114	9,5	242

FORMA FORM



1



6

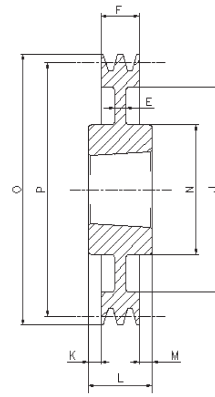

7

SPB/1

Descrizione Description Beschreibung Description Descripción	Gole Grooves Rillen Gorges Canales	P	O	Forma Form Forme Forme Forma	Bussola Bush Buchse Moyeu Casquillo	Ø MAX	E	F	J	K	L	M	N
SPB100-01	1	100	107	1	1610	42	-	25	-	-	25	-	-
SPB106-1	1	106	113	1	1610	42	-	25	-	-	25	-	-
SPB112-01	1	112	119	1	1610	42	-	25	-	-	25	-	-
SPB118-01	1	118	125	1	1610	42	-	25	-	-	25	-	-
SPB125-01	1	125	132	1	1610	42	-	25	-	-	25	-	-
SPB132-01	1	132	139	1	1610	42	-	25	-	-	25	-	-
SPB140-01	1	140	147	1	1610	42	-	25	-	-	25	-	-
SPB150-01	1	150	157	1	1610	42	-	25	-	-	25	-	-
SPB160-01	1	160	167	1	1610	42	-	25	-	-	25	-	-
SPB170-01	1	170	177	1	1610	42	-	25	-	-	25	-	-
SPB180-01	1	180	187	6	1610	42	15	25	132	-	25	-	90
SPB190-01	1	190	197	7	2012	50	15	25	147	3,5	32	3,5	104
SPB200-01	1	200	207	7	2012	50	15	25	157	3,5	32	3,5	104
SPB212-01	1	212	219	7	2012	50	15	25	169	3,5	32	3,5	104
SPB224-01	1	224	231	7	2012	50	15	25	181	3,5	32	3,5	104
SPB236-01	1	236	243	7	2012	50	15	25	193	3,5	32	3,5	104
SPB250-01	1	250	257	7	2012	50	20	25	207	3,5	32	3,5	104
SPB280-01	1	280	287	7	2012	50	20	25	237	3,5	32	3,5	104
SPB300-01	1	300	307	7	2012	50	20	25	258	3,5	32	3,5	104
SPB315-01	1	315	322	7	2012	50	20	25	272	3,5	32	3,5	104

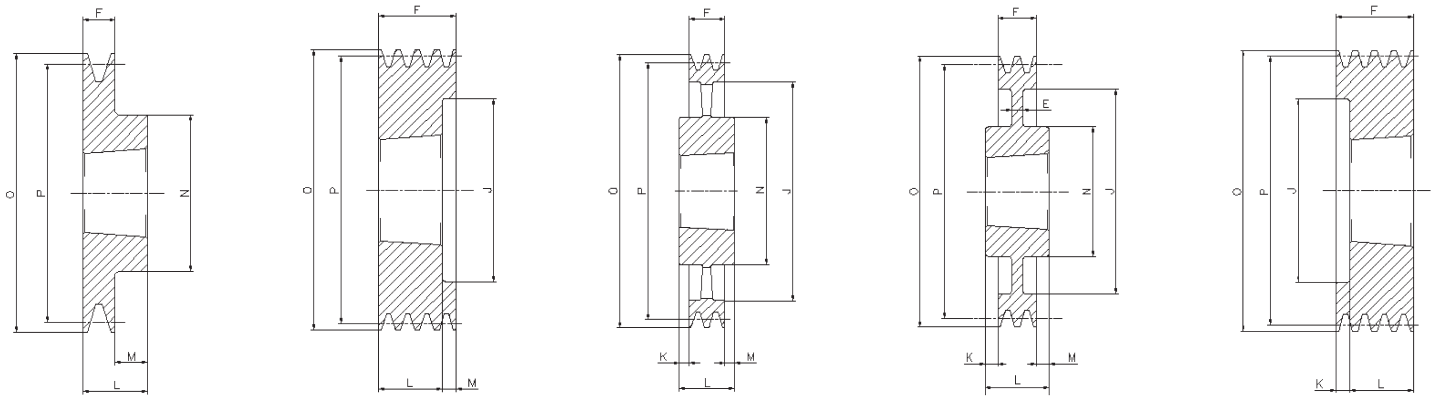

1

2

4

7

8

SPB/2

Descrizione Description Beschreibung Description Descripción	Gole Grooves Rillen Gorges Canales	P	O	Forma Form Forme Forme Forma	Bussola Bush Buchse Moyeu Casquillo	Ø MAX	E	F	J	K	L	M	N
SPB100-02	2	100	107	8	1610	42	-	44	62	19,0	25	-	-
SPB106-02	2	106	113	8	1610	42	-	44	67	19,0	25	-	-
SPB112-02	2	112	119	8	1610	42	-	44	72	19,0	25	-	-
SPB118-02	2	118	125	2	1610	42	-	44	78	-	25	19,0	-
SPB125-02	2	125	132	2	2012	50	-	44	82	-	32	12,0	-
SPB132-02	2	132	139	2	2012	50	-	44	89	-	32	12,0	-
SPB140-02	2	140	147	2	2012	50	-	44	97	-	32	12,0	-
SPB150-02	2	150	157	2	2012	50	-	44	107	-	32	12,0	-
SPB160-02	2	160	167	2	2012	50	-	44	117	-	32	12,0	-
SPB170-02	2	170	177	2	2012	50	-	44	127	-	32	12,0	-
SPB180-02	2	180	187	1	2517	60	-	44	-	-	45	1,0	120
SPB190-02	2	190	197	1	2517	60	-	44	-	-	45	1,0	120
SPB200-02	2	200	207	1	2517	60	-	44	-	-	45	1,0	117
SPB212-02	2	212	219	7	2517	60	20	44	169	-	45	1,0	117
SPB224-02	2	224	231	7	2517	60	15	44	181	-	45	1,0	117
SPB236-02	2	236	243	7	2517	60	15	44	193	-	45	1,0	117
SPB250-02	2	250	257	7	2517	60	20	44	207	-	45	1,0	125
SPB280-02	2	280	287	7	2517	60	20	44	237	-	45	1,0	125
SPB300-02	2	300	307	7	2517	60	20	44	257	-	45	1,0	125
SPB315-02	2	315	322	7	2517	60	20	44	272	-	45	1,0	125
SPB335-02	2	335	342	7	2517	60	20	44	292	-	45	1,0	125
SPB355-02	2	355	362	7	3020	75	15	44	312	3,5	51	3,5	144
SPB400-02	2	400	407	4	3020	75	-	44	357	3,5	51	3,5	150
SPB450-02	2	450	457	4	3020	75	-	44	407	3,5	51	3,5	150
SPB500-02	2	500	507	4	3020	75	-	44	457	3,5	51	3,5	150
SPB560-02	2	560	567	4	3030	75	-	44	517	4,0	76	28,0	150
SPB630-02	2	630	637	4	3030	75	-	44	587	16,0	76	16,0	150

FORMA FORM

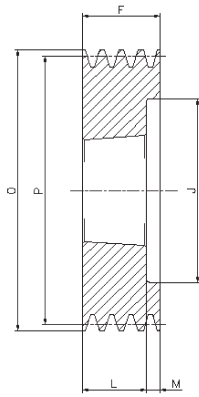

2

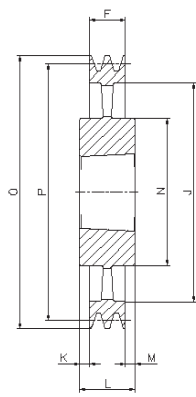

4

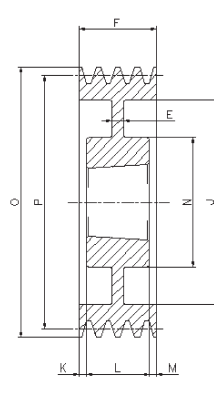

6

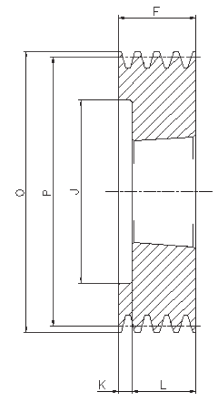

8

SPB/3

Descrizione Description Beschreibung Description Descripción	Gole Grooves Rillen Gorges Canales	P	O	Forma Form Forme Forme Forma	Bussola Bush Buchse Moyeu Casquillo	Ø MAX	E	F	J	K	L	M	N
SPB100-03	3	100	107	8	1610	42	-	63	62	38,0	25	-	-
SPB106-03	3	106	113	8	1610	42	-	63	67	38,0	25	-	-
SPB112-03	3	112	119	8	1610	42	-	63	72	38,0	25	-	-
SPB118-03	3	118	125	2	1610	42	-	63	78	-	25	38,0	-
SPB125-03	3	125	132	2	2012	50	-	63	82	-	32	31,0	-
SPB132-03	3	132	139	2	2012	50	-	63	89	-	32	31,0	-
SPB140-03	3	140	147	2	2012	50	-	63	97	-	32	31,0	-
SPB150-03	3	150	157	2	2517	60	-	63	107	-	45	18,0	-
SPB160-03	3	160	167	2	2517	60	-	63	117	-	45	18,0	-
SPB170-03	3	170	177	2	2517	60	-	63	127	-	45	18,0	-
SPB180-03	3	180	187	2	2517	60	-	63	137	-	45	18,0	-
SPB190-03	3	190	197	2	2517	60	-	63	147	-	45	18,0	-
SPB200-03	3	200	207	2	2517	60	-	63	157	-	45	18,0	-
SPB212-03	3	212	219	6	2517	60	15	63	169	-	45	18,0	117
SPB224-03	3	224	231	6	2517	60	15	63	181	-	45	18,0	117
SPB236-03	3	236	243	6	2517	60	15	63	193	-	45	18,0	117
SPB250-03	3	250	257	6	3020	75	20	63	207	-	51	12,0	144
SPB280-03	3	280	287	6	3020	75	20	63	237	6,0	51	6,0	144
SPB300-03	3	300	307	6	3020	75	20	63	257	6,0	51	6,0	144
SPB315-03	3	315	322	6	3020	75	20	63	272	6,0	51	6,0	144
SPB335-03	3	335	342	6	3020	75	20	63	292	6,0	51	6,0	144
SPB355-03	3	355	362	6	3020	75	15	63	312	6,0	51	6,0	144
SPB400-03	3	400	407	4	3535	90	-	63	357	13,0	89	13,0	175
SPB450-03	3	450	457	4	3535	90	-	63	407	-	89	26,0	175
SPB500-03	3	500	507	4	3535	90	-	63	457	-	89	26,0	175
SPB560-03	3	560	567	4	3535	90	-	63	517	-	89	26,0	175
SPB630-03	3	630	637	4	3535	90	-	63	587	-	89	26,0	175
SPB710-03	3	710	717	4	3535	90	-	63	664	13,0	89	13,0	175
SPB800-03	3	800	807	4	3535	90	-	63	754	13,0	89	13,0	175
SPB900-03	3	900	907	4	3535	90	-	63	854	13,0	89	13,0	175
SPB1000-03	3	1000	1007	4	4040	100	-	63	954	19,5	102	19,5	210
SPB1250-03	3	1250	1257	4	4040	100	-	63	1204	19,5	102	19,5	210

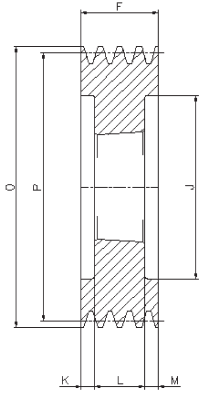

3

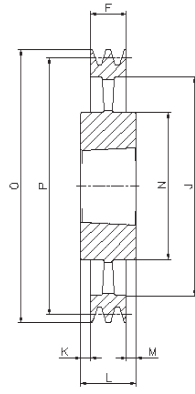

4

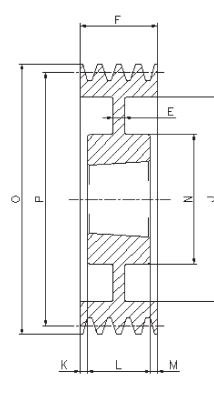

6

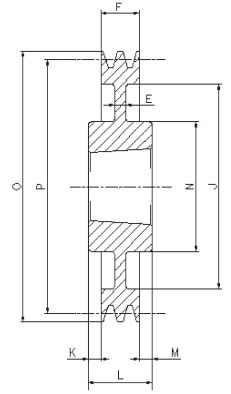

7

SPB/4

Descrizione Description Beschreibung Description Descripción	Gole Grooves Rillen Gorges Canales	P	O	Forma Form Forme Forme Forma	Bussola Bush Buchse Moyeu Casquillo	Ø MAX	E	F	J	K	L	M	N
SPB100-04	4	100	117	8	1615	42	-	82	60	44,0	38	-	-
SPB112-04	4	112	119	8	2012	42	-	82	72	50,0	32	-	-
SPB118-04	4	118	125	8	1610	42	-	82	75	57,0	25	-	-
SPB125-04	4	125	132	3	2012	50	-	82	82	25,0	32	25,0	-
SPB132-04	4	132	139	3	2012	50	-	82	89	25,0	32	25,0	-
SPB140-04	4	140	147	3	2517	60	-	82	100	18,5	45	18,5	-
SPB150-04	4	150	157	3	2517	60	-	82	107	18,5	45	18,5	-
SPB160-04	4	160	167	3	2517	60	-	82	117	18,5	45	18,5	-
SPB170-04	4	170	177	3	2517	60	-	82	127	18,5	45	18,5	-
SPB180-04	4	180	187	3	2517	60	-	82	137	18,5	45	18,5	-
SPB190-04	4	190	197	3	2517	60	-	82	147	18,5	45	18,5	-
SPB200-04	4	200	207	3	3020	75	-	82	157	15,5	51	15,5	-
SPB212-04	4	212	219	3	3020	75	-	82	169	15,5	51	15,5	-
SPB224-04	4	224	231	3	3020	75	-	82	181	15,5	51	15,5	-
SPB236-04	4	236	243	3	3020	75	-	82	193	15,5	51	15,5	-
SPB250-04	4	250	257	6	3020	75	25	82	207	15,5	51	15,5	144
SPB280-04	4	280	287	6	3020	75	25	82	237	15,5	51	15,5	144
SPB300-04	4	300	307	7	3535	90	25	82	257	-	89	7,0	175
SPB315-04	4	315	322	7	3535	90	25	82	272	3,5	89	3,5	175
SPB335-04	4	335	342	7	3535	90	25	82	292	3,5	89	3,5	175
SPB355-04	4	355	362	7	3535	90	25	82	312	3,5	89	3,5	175
SPB400-04	4	400	407	4	3535	90	-	82	357	3,5	89	3,5	175
SPB450-04	4	450	457	4	3535	90	-	82	407	-	89	7,0	175
SPB500-04	4	500	507	4	3535	90	-	82	457	-	89	7,0	175
SPB560-04	4	560	567	4	3535	90	-	82	517	-	89	7,0	175
SPB630-04	4	630	637	4	3535	90	-	82	587	-	89	7,0	175
SPB710-04	4	710	717	4	3535	90	-	82	664	3,5	89	3,5	175
SPB800-04	4	800	807	4	4040	100	-	82	754	10,0	102	10,0	210
SPB900-04	4	900	907	4	4040	100	-	82	854	10,0	102	10,0	210
SPB1000-04	4	1000	1007	4	4040	100	-	82	954	10,0	102	16,0	210
SPB1250-04	4	1250	1257	4	4545	110	-	82	1204	16,0	114	16,0	210

FORMA FORM

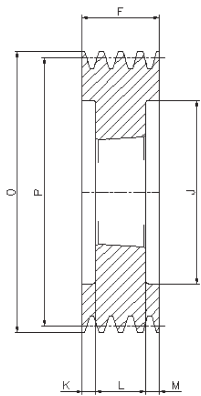

3

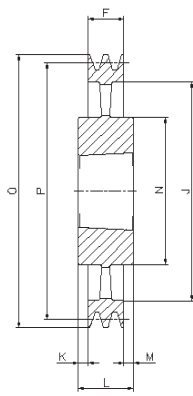

4

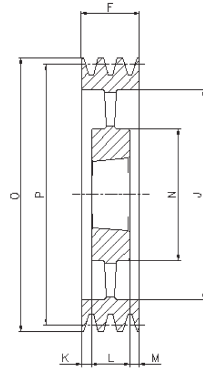

5

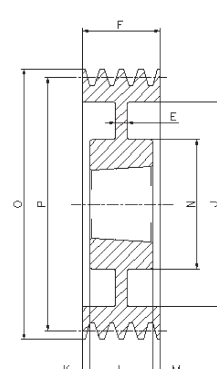

6

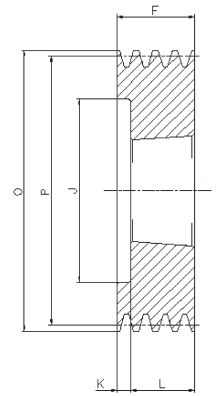

8

SPB/5

Descrizione Description Beschreibung Description Descripción	Gole Grooves Rillen Gorges Canales	P	O	Forma Form Forme Forma Forma	Bussola Bush Buchse Moyeu Casquillo	Ø MAX	E	F	J	K	L	M	N
SPB125-05	5	125	132	8	2012	50	-	101	87	69,0	32	-	-
SPB132-05	5	132	139	8	2517	60	-	101	94	56,0	45	-	-
SPB140-05	5	140	147	3	2517	60	-	101	97	28,0	45	28,0	-
SPB150-05	5	150	157	3	2517	60	-	101	107	28,0	45	28,0	-
SPB160-05	5	160	167	3	2517	60	-	101	117	28,0	45	28,0	-
SPB170-05	5	170	177	3	3020	75	-	101	127	25,0	51	25,0	-
SPB180-05	5	180	187	3	3020	75	-	101	137	25,0	51	25,0	-
SPB190-05	5	190	197	3	3020	75	-	101	147	25,0	51	25,0	-
SPB200-05	5	200	207	3	3020	75	-	101	157	25,0	51	25,0	-
SPB212-05	5	212	219	3	3020	75	-	101	169	25,0	51	25,0	-
SPB224-05	5	224	231	3	3020	75	-	101	181	25,0	51	25,0	-
SPB236-05	5	236	243	3	3535	90	-	101	193	6,0	89	6,0	-
SPB250-05	5	250	257	3	3535	90	-	101	207	6,0	89	6,0	-
SPB280-05	5	280	287	6	3535	90	25	101	237	6,0	89	6,0	175
SPB300-05	5	300	307	6	3535	90	25	101	257	6,0	89	6,0	175
SPB315-05	5	315	322	6	3535	90	25	101	272	6,0	89	6,0	175
SPB335-05	5	335	342	6	3535	90	25	101	292	6,0	89	6,0	175
SPB355-05	5	355	362	6	3535	90	17	101	312	6,0	89	6,0	175
SPB400-05	5	400	407	5	3535	90	-	101	357	6,0	89	6,0	175
SPB450-05	5	450	457	5	3535	90	-	101	407	-	89	12,0	175
SPB500-05	5	500	507	5	3535	90	-	101	457	-	89	12,0	175
SPB560-05	5	560	567	4	4040	100	-	101	517	-	102	1,0	210
SPB630-05	5	630	637	4	4040	100	-	101	587	-	102	1,0	210
SPB710-05	5	710	717	4	4040	100	-	101	664	-	102	1,0	210
SPB800-05	5	800	807	4	4040	100	-	101	754	-	102	1,0	210
SPB900-05	5	900	907	4	4040	100	-	101	854	-	102	1,0	210
SPB1000-05	5	1000	1007	4	4545	110	-	101	954	6,5	114	6,5	242
SPB1250-05	5	1250	1257	4	4545	110	-	101	1204	6,5	114	6,5	242

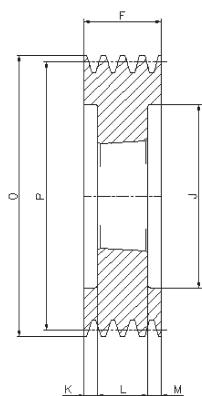
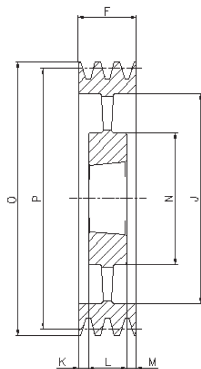
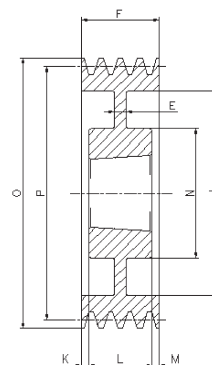

3

5

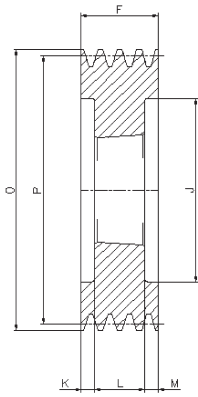
6
SPB/6

Descrizione Description Beschreibung Description Descripción	Gole Grooves Rillen Gorges Canales	P	O	Forma Form Forme Forma Forma	Bussola Bush Buchse Moyeu Casquillo	Ø MAX	E	F	J	K	L	M	N
SPB140-06	6	140	147	3	2517	60	-	120	100	37,5	45	37,5	-
SPB150-06	6	150	157	3	2517	60	-	120	107	37,5	45	37,5	-
SPB160-06	6	160	167	3	3020	75	-	120	117	34,5	51	34,5	-
SPB170-06	6	170	177	3	3020	75	-	120	127	34,5	51	34,5	-
SPB180-06	6	180	187	3	3020	75	-	120	137	34,5	51	34,5	-
SPB190-06	6	190	197	3	3020	75	-	120	147	34,5	51	34,5	-
SPB200-06	6	200	207	3	3020	75	-	120	157	34,5	51	34,5	-
SPB212-06	6	212	219	3	3535	90	-	120	169	15,5	89	15,5	-
SPB224-06	6	224	231	3	3535	90	-	120	181	15,5	89	15,5	-
SPB236-06	6	236	243	3	3535	90	-	120	193	15,5	89	15,5	-
SPB250-06	6	250	257	3	3535	90	-	120	207	15,5	89	15,5	-
SPB280-06	6	280	287	6	3535	90	25	120	237	15,5	89	15,5	175
SPB300-06	6	300	307	6	3535	90	25	120	257	15,5	89	15,5	175
SPB315-06	6	315	322	6	3535	90	25	120	272	15,5	89	15,5	175
SPB335-06	6	335	342	6	3535	90	25	120	292	15,5	89	15,5	175
SPB355-06	6	355	362	6	3535	90	25	120	312	15,5	89	15,5	175
SPB400-06	6	400	407	5	3535	90	-	120	357	15,5	89	15,5	175
SPB450-06	6	450	457	5	4040	100	-	120	407	-	102	18,0	210
SPB500-06	6	500	507	5	4040	100	-	120	457	-	102	18,0	210
SPB560-06	6	560	567	5	4040	100	-	120	517	-	102	18,0	210
SPB630-06	6	630	637	5	4040	100	-	120	587	-	102	18,0	210
SPB710-06	6	710	717	5	4040	100	-	120	664	9,0	102	9,0	210
SPB800-06	6	800	807	5	4545	110	-	120	754	3,0	114	3,0	242
SPB900-06	6	900	907	5	4545	110	-	120	854	3,0	114	3,0	242
SPB1000-06	6	1000	1007	5	4545	110	-	120	954	3,0	114	3,0	242
SPB1250-06	6	1250	1257	5	4545	110	-	120	1204	3,0	114	3,0	242

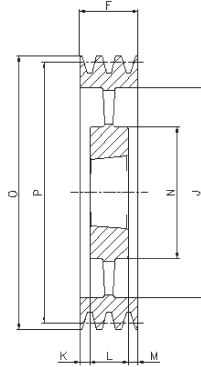
FORMA FORM



3



5

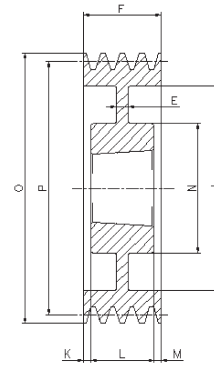

6

SPB/8

Descrizione Description Beschreibung Description Descripción	Gole Grooves Rillen Gorges Canales	P	O	Forma Form Forme Forme Forma	Bussola Bush Buchse Moyeu Casquillo	ø MAX	E	F	J	K	L	M	N
SPB140-08	8	140	147	3	2517	60	-	158	97	56,5	45	56,5	-
SPB160-08	8	160	167	3	3020	75	-	158	117	53,5	51	53,5	-
SPB170-08	8	170	177	3	3030	75	-	158	127	41,0	76	41,0	-
SPB180-08	8	180	187	3	3030	75	-	158	137	41,0	76	41,0	-
SPB190-08	8	190	197	3	3030	75	-	158	147	41,0	76	41,0	-
SPB200-08	8	200	207	3	3535	90	-	158	157	34,5	89	34,5	-
SPB212-08	8	212	219	3	3535	90	-	158	169	34,5	89	34,5	-
SPB224-08	8	224	231	3	3535	90	-	158	181	34,5	89	34,5	-
SPB236-08	8	236	243	3	3535	90	-	158	193	34,5	89	34,5	-
SPB250-08	8	250	257	3	3535	90	-	158	207	34,5	89	34,5	-
SPB280-08	8	280	287	6	3535	90	25	158	237	34,5	89	34,5	175
SPB300-08	8	300	307	6	3535	90	25	158	257	34,5	89	34,5	175
SPB315-08	8	315	322	6	3535	90	25	158	272	34,5	89	34,5	175
SPB335-08	8	335	342	6	3535	90	25	158	292	34,5	89	34,5	175
SPB355-08	8	355	362	6	3535	90	25	158	312	34,5	89	34,5	175
SPB400-08	8	400	407	6	4040	100	30	158	357	28,0	102	28,0	210
SPB450-08	8	450	457	5	4040	100	-	158	407	28,0	102	28,0	210
SPB500-08	8	500	507	5	4040	100	-	158	457	28,0	102	28,0	210
SPB560-08	8	560	567	5	4545	110	-	158	517	22,0	114	22,0	242
SPB630-08	8	630	637	5	4545	110	-	158	587	22,0	114	22,0	242
SPB710-08	8	710	717	5	4545	110	-	158	664	22,0	114	22,0	242
SPB800-08	8	800	807	5	4545	110	-	158	754	22,0	114	22,0	242
SPB900-08	8	900	907	5	4545	110	-	158	854	22,0	114	22,0	242
SPB1000-08	8	1000	1007	5	5050	125	-	158	954	15,5	127	15,5	267
SPB1250-08	8	1250	1257	5	5050	125	-	158	1204	15,5	127	15,5	267

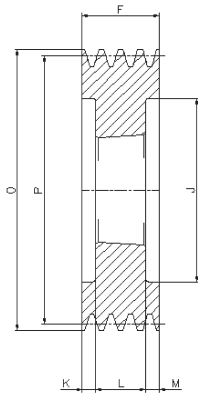
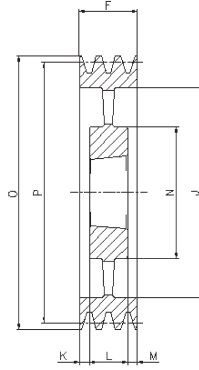
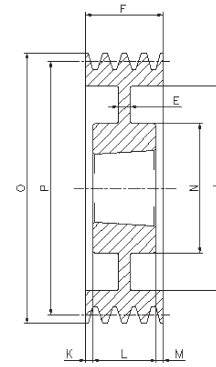

3

5

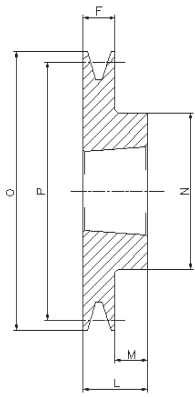
6
SPB/10

Descrizione Description Beschreibung Description Descripción	Gole Grooves Rillen Gorges Canales	P	O	Forma Form Forme Forme Forma	Bussola Bush Buchse Moyeu Casquillo	g MAX	E	F	J	K	L	M	N
SPB200-10	10	200	207	3	3535	90	-	196	157	53,5	89	53,5	-
SPB224-10	10	224	231	3	3535	90	-	196	181	53,5	89	53,5	-
SPB236-10	10	236	243	3	3535	90	-	196	193	53,5	89	53,5	-
SPB250-10	10	250	257	3	3535	90	-	196	207	53,5	89	53,5	-
SPB280-10	10	280	287	6	3535	90	30	196	237	53,5	89	53,5	175
SPB315-10	10	315	322	6	3535	90	30	196	272	53,5	89	53,5	175
SPB335-10	10	335	342	6	4040	100	30	196	292	47,0	102	47,0	210
SPB355-10	10	355	362	6	4040	100	30	196	312	47,0	102	47,0	210
SPB400-10	10	400	407	6	4040	100	30	196	357	47,0	102	47,0	210
SPB450-10	10	450	457	5	4545	110	-	196	407	41,0	114	41,0	242
SPB500-10	10	500	507	5	4545	110	-	196	457	41,0	114	41,0	242
SPB560-10	10	560	567	5	4545	110	-	196	517	41,0	114	41,0	242
SPB630-10	10	630	637	5	4545	110	-	196	587	41,0	114	41,0	242
SPB710-10	10	710	717	5	4545	110	-	196	664	41,0	114	41,0	242
SPB800-10	10	800	807	5	4545	110	-	196	754	41,0	114	41,0	242
SPB900-10	10	900	907	5	5050	125	-	196	854	34,5	127	34,5	267
SPB1000-10	10	1000	1007	5	5050	125	-	196	954	34,5	127	34,5	267

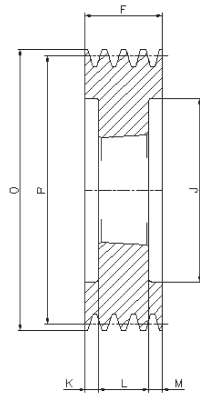
FORMA FORM



1



3

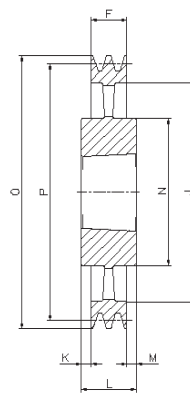

4

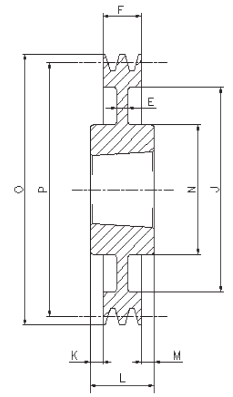

7

SPC/3

Descrizione Description Beschreibung Description Descripción	Gole Grooves Rillen Gorges Canales	P	O	Forma Form Forme Forme Forma	Bussola Bush Buchse Moyeu Casquillo	ø MAX	E	F	J	K	L	M	N
SPC200-03	3	200	209,6	3	2517	60	-	85	144	20,0	45	20,0	-
SPC212-03	3	212	221,6	3	3020	75	-	85	156	17,0	51	17,0	-
SPC224-03	3	224	233,6	3	3020	75	-	85	168	17,0	51	17,0	-
SPC236-03	3	236	245,6	3	3020	75	-	85	180	17,0	51	17,0	-
SPC250-03	3	250	259,6	3	3020	75	-	85	194	17,0	51	17,0	-
SPC265-03	3	265	274,6	1	3535	90	-	85	209	-	89	4,0	175
SPC280-03	3	280	289,6	1	3535	90	-	85	224	-	89	4,0	175
SPC300-03	3	300	309,6	7	3535	90	20	85	244	2,0	89	2,0	175
SPC315-03	3	315	324,6	7	3535	90	20	85	259	2,0	89	2,0	175
SPC335-03	3	335	344,6	7	3535	90	20	85	279	2,0	89	2,0	175
SPC355-03	3	355	364,6	7	3535	90	20	85	299	2,0	89	2,0	175
SPC375-03	3	375	384,6	7	3535	90	25	85	319	2,0	89	2,0	175
SPC400-03	3	400	409,6	7	3535	90	17	85	344	2,0	89	2,0	175
SPC425-03	3	425	434,6	7	3535	90	17	85	369	2,0	89	2,0	175
SPC450-03	3	450	459,6	4	3535	90	-	85	394	2,0	89	2,0	175
SPC475-03	3	475	484,6	4	3535	90	-	85	419	2,0	89	2,0	175
SPC500-03	3	500	509,6	4	3535	90	-	85	444	2,0	89	2,0	175
SPC530-03	3	530	539,6	4	3535	90	-	85	474	2,0	89	2,0	175
SPC560-03	3	560	569,6	4	3535	90	-	85	504	2,0	89	2,0	175
SPC630-03	3	630	639,6	4	4040	100	-	85	574	8,5	102	8,5	210
SPC710-03	3	710	719,6	4	4545	110	-	85	652	14,5	114	14,5	242
SPC800-03	3	800	809,6	4	4545	110	-	85	737	14,5	114	14,5	242
SPC1000-03	3	1000	1009,6	4	5050	125	-	85	937	21,0	127	21,0	267
SPC1250-03	3	1250	1259,6	4	5050	125	-	85	1187	21,0	127	21,0	267

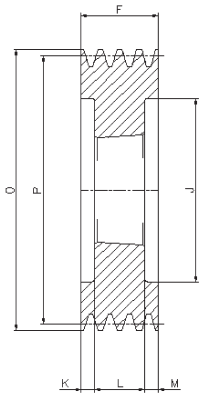

3

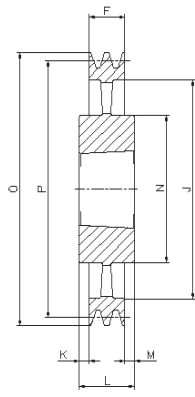

4

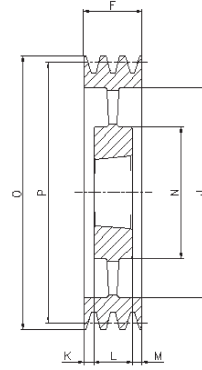

5

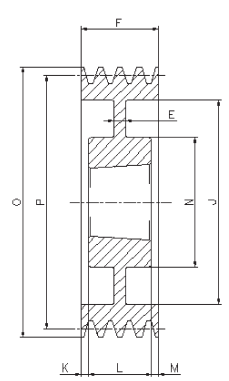

6

SPC/4

Descrizione Description Beschreibung Description Descripción	Gole Grooves Rillen Gorges Canales	P	O	Forma Form Forme Forme Forma	Bussola Bush Buchse Moyeu Casquillo	∅ MAX	E	F	J	K	L	M	N
SPC200-04	4	200	209,6	3	3020	75	-	111	144	30,0	51	30,0	-
SPC212-04	4	212	221,6	3	3020	75	-	111	156	30,0	51	30,0	-
SPC224-04	4	224	233,6	3	3535	90	-	111	168	11,0	89	11,0	-
SPC236-04	4	236	245,6	3	3535	90	-	111	180	11,0	89	11,0	-
SPC250-04	4	250	259,6	3	3535	90	-	111	194	11,0	89	11,0	-
SPC265-04	4	265	274,6	3	3535	90	-	111	209	11,0	89	11,0	-
SPC280-04	4	280	289,6	6	3535	90	18	111	224	11,0	89	11,0	175
SPC300-04	4	300	309,6	6	3535	90	20	111	244	11,0	89	11,0	175
SPC315-04	4	315	324,6	6	3535	90	20	111	259	11,0	89	11,0	175
SPC335-04	4	335	344,6	6	3535	90	20	111	279	11,0	89	11,0	175
SPC355-04	4	355	364,6	6	3535	90	20	111	299	11,0	89	11,0	175
SPC375-04	4	375	384,6	6	3535	90	25	111	319	11,0	89	11,0	175
SPC400-04	4	400	409,6	6	3535	90	18	111	344	11,0	89	11,0	175
SPC425-04	4	425	434,6	6	3535	90	18	111	369	11,0	89	11,0	175
SPC450-04	4	450	459,6	5	3535	90	-	111	394	11,0	89	11,0	175
SPC475-04	4	475	484,6	5	3535	90	-	111	419	11,0	89	11,0	175
SPC500-04	4	500	509,6	5	3535	90	-	111	444	11,0	89	11,0	175
SPC530-04	4	530	539,6	5	4040	100	-	111	474	4,5	102	4,5	210
SPC560-04	4	560	569,6	5	4040	100	-	111	504	4,5	102	4,5	210
SPC630-04	4	630	639,6	4	4545	110	-	111	574	1,5	114	1,5	242
SPC710-04	4	710	719,6	4	5050	125	-	111	654	8,0	127	8,0	267
SPC800-04	4	800	809,6	4	5050	125	-	111	737	8,0	127	8,0	267
SPC1000-04	4	1000	1009,6	4	5050	125	-	111	937	8,0	127	8,0	267
SPC1250-04	4	1250	1259,6	4	5050	125	-	111	1187	8,0	127	8,0	267

FORMA FORM

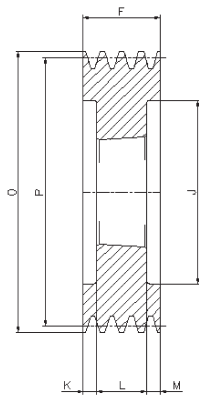

3

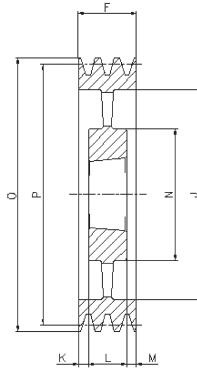

5

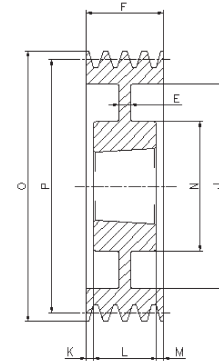

6

SPC/5

Descrizione Description Beschreibung Description Descripción	Gole Grooves Rillen Gorges Canales	P	O	Forma Form Forme Forme Forma	Bussola Bush Buchse Moyeu Casquillo	Ø MAX	E	F	J	K	L	M	N
SPC200-05	5	200	209,6	3	3535	90	-	136	144	23,5	89	23,5	-
SPC212-05	5	212	221,6	3	3535	90	-	136	156	23,5	89	23,5	-
SPC224-05	5	224	233,6	3	3535	90	-	136	168	23,5	89	23,5	-
SPC236-05	5	236	245,6	3	3535	90	-	136	180	23,5	89	23,5	-
SPC250-05	5	250	259,6	3	3535	90	-	136	194	23,5	89	23,5	-
SPC265-05	5	265	274,6	3	3535	90	-	136	209	23,5	89	23,5	-
SPC280-05	5	280	289,6	3	3535	90	-	136	224	23,5	89	23,5	-
SPC300-05	5	300	309,6	6	3535	90	20	136	244	23,5	89	23,5	175
SPC315-05	5	315	324,6	6	3535	90	20	136	259	23,5	89	23,5	175
SPC335-05	5	335	344,6	6	3535	90	20	136	279	23,5	89	23,5	175
SPC355-05	5	355	364,6	6	3535	90	20	136	299	23,5	89	23,5	175
SPC375-05	5	375	384,6	6	3535	90	25	136	319	23,5	89	23,5	175
SPC400-05	5	400	409,6	6	3535	90	15	136	344	23,5	89	23,5	175
SPC425-05	5	425	434,6	6	3535	90	20	136	369	23,5	89	23,5	175
SPC450-05	5	450	459,6	5	4040	100	-	136	394	17,0	102	17,0	210
SPC475-05	5	475	484,6	5	4040	100	-	136	419	17,0	102	17,0	210
SPC500-05	5	500	509,6	5	4040	100	-	136	444	17,0	102	17,0	210
SPC530-05	5	530	539,6	5	4545	110	-	136	474	11,0	114	11,0	240
SPC560-05	5	560	569,6	5	4545	110	-	136	504	11,0	114	11,0	242
SPC630-05	5	630	639,6	5	5050	125	-	136	574	4,5	127	4,5	267
SPC710-05	5	710	719,6	5	5050	125	-	136	654	4,5	127	4,5	267
SPC800-05	5	800	809,6	5	5050	125	-	136	737	4,5	127	4,5	267
SPC1000-05	5	1000	1009,6	5	5050	125	-	136	937	4,5	127	4,5	267
SPC1250-05	5	1250	1259,6	5	5050	125	-	136	1187	4,5	127	4,5	267

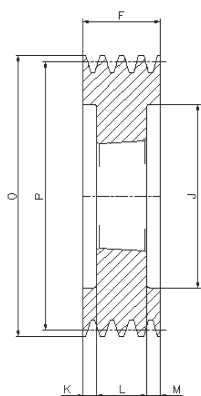
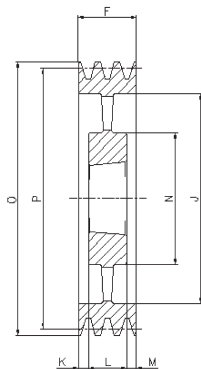
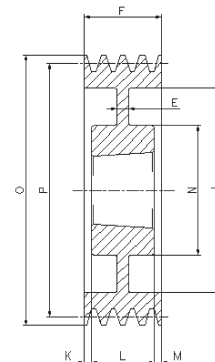

3

5

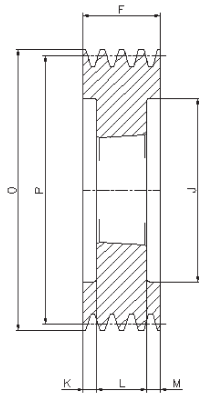
6
SPC/6

Descrizione Description Beschreibung Description Descripción	Gole Grooves Fillen Gorges Canales	P	O	Forma Form Forme Forme Forma	Bussola Bush Buchse Moyeu Casquillo	∅ MAX	E	F	J	K	L	M	N
SPC200-06	6	200	209,6	3	3535	90	-	162	144	36,5	89	36,5	-
SPC212-06	6	212	221,6	3	3535	90	-	162	156	36,5	89	36,5	-
SPC224-06	6	224	233,6	3	3535	90	-	162	168	36,5	89	36,5	-
SPC236-06	6	236	245,6	3	3535	90	-	162	180	36,5	89	36,5	-
SPC250-06	6	250	259,6	3	3535	90	-	162	194	36,5	89	36,5	-
SPC265-06	6	265	274,6	3	3535	90	-	162	209	36,5	89	36,5	-
SPC280-06	6	280	289,6	6	3535	90	20	162	224	36,5	89	36,5	175
SPC300-06	6	300	309,6	6	3535	90	20	162	244	36,5	89	36,5	175
SPC315-06	6	315	324,6	6	3535	90	20	162	259	36,5	89	36,5	175
SPC335-06	6	335	344,6	6	3535	90	20	162	279	36,5	89	36,5	175
SPC355-06	6	355	364,6	6	3535	90	20	162	299	36,5	89	36,5	175
SPC375-06	6	375	384,6	6	4040	100	30	162	319	30,0	102	30,0	210
SPC400-06	6	400	409,6	6	4040	100	30	162	344	30,0	102	30,0	210
SPC425-06	6	425	434,6	6	4040	100	30	162	369	30,0	102	24,0	210
SPC450-06	6	450	459,6	6	4545	110	30	162	394	24,0	114	24,0	242
SPC475-06	6	475	484,6	6	4545	110	30	162	419	24,0	114	24,0	242
SPC500-06	6	500	509,6	5	4545	110	-	162	444	24,0	114	24,0	242
SPC530-06	6	530	539,6	5	5050	125	-	162	474	17,5	114	17,5	265
SPC560-06	6	560	569,6	5	5050	125	-	162	504	17,5	127	17,5	267
SPC630-06	6	630	639,6	5	5050	125	-	162	574	17,5	127	17,5	267
SPC710-06	6	710	719,6	5	5050	125	-	162	654	17,5	127	17,5	267
SPC800-06	6	800	809,6	5	5050	125	-	162	737	17,5	127	17,5	267
SPC1000-06	6	1000	1009,6	5	5050	125	-	162	937	17,5	127	17,5	267
SPC1250-06	6	1250	1259,6	5	5050	125	-	162	1187	17,5	127	17,5	267

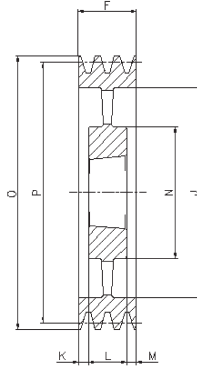
FORMA FORM



3



5

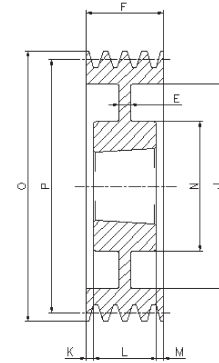

6

SPC/8

Descrizione Description Beschreibung Description Descripción	Gole Grooves Rillen Gorges Canales	P	O	Forma Form Forme Forme Forma	Bussola Bush Buchse Moyeu Casquillo	Ø MAX	E	F	J	K	L	M	N
SPC200-08	8	200	209,6	3	3535	90	-	213	144	62,0	89	62,0	-
SPC212-08	8	212	221,6	3	3535	90	-	213	156	62,0	89	62,0	-
SPC224-08	8	224	233,6	3	3535	90	-	213	168	62,0	89	62,0	-
SPC236-08	8	236	245,6	3	3535	90	-	213	180	62,0	89	62,0	-
SPC250-08	8	250	259,6	3	3535	90	-	213	194	62,0	89	62,0	-
SPC265-08	8	265	274,6	3	3535	90	-	213	209	62,0	89	62,0	-
SPC280-08	8	280	289,6	3	3535	90	-	213	224	62,0	89	62,0	-
SPC300-08	8	300	309,6	3	4040	100	-	213	244	55,5	102	55,5	-
SPC315-08	8	315	324,6	3	4040	100	-	213	259	55,5	102	55,5	-
SPC335-08	8	335	344,6	6	4040	100	50	213	279	55,5	102	55,5	210
SPC355-08	8	355	364,6	6	4040	100	40	213	299	55,5	102	55,5	210
SPC375-08	8	375	384,6	6	4545	110	30	213	319	49,5	114	49,5	242
SPC400-08	8	400	409,6	6	4545	110	30	213	344	49,5	114	49,5	242
SPC425-08	8	425	434,6	6	4545	110	30	213	369	49,5	114	49,5	240
SPC450-08	8	450	459,6	6	5050	125	30	213	394	43,0	127	43,0	267
SPC475-08	8	475	484,6	6	5050	125	30	213	419	43,0	127	43,0	267
SPC500-08	8	500	509,6	6	5050	125	30	213	444	43,0	127	43,0	267
SPC530-08	8	530	539,6	6	5050	125	30	213	474	43,0	127	43,0	267
SPC560-08	8	560	569,6	5	5050	125	-	213	504	43,0	127	43,0	267
SPC630-08	8	630	639,6	5	5050	125	-	213	574	43,0	127	43,0	267
SPC710-08	8	710	719,6	5	5050	125	-	213	654	43,0	127	43,0	267
SPC800-08	8	800	809,6	5	5050	125	-	213	737	43,0	127	43,0	267
SPC1000-08	8	1000	1009,6	5	5050	125	-	213	937	43,0	127	43,0	267
SPC1250-08	8	1250	1259,6	5	5050	125	-	213	1187	43,0	127	43,0	267

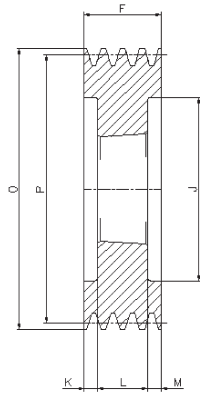
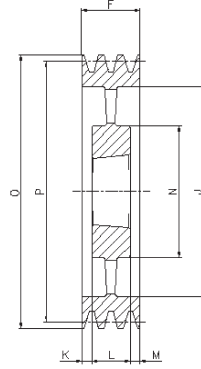
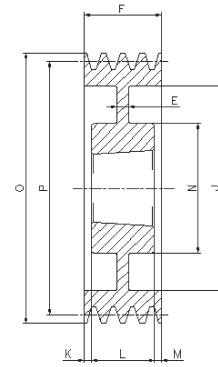

3

5

6
SPC/10

Descrizione Description Beschreibung Description Descripción	Gole Grooves Rillen Gorges Canales	P	O	Forma Form Forme Forme Forma	Bussola Bush Buchse Moyeu Casquillo	Ø MAX	E	F	J	K	L	M	N
SPC224-10	10	224	233,6	3	4040	100	-	264	170	81,0	102	81,0	-
SPC250-10	10	250	259,6	3	4040	100	-	264	194	81,0	102	81,0	-
SPC280-10	10	280	289,6	3	4040	100	-	264	224	81,0	102	81,0	-
SPC300-10	10	300	309,6	3	4545	110	-	264	244	75,0	114	75,0	-
SPC315-10	10	315	324,6	3	4545	110	-	264	259	75,0	114	75,0	-
SPC355-10	10	355	364,6	3	4545	110	-	264	299	75,0	114	75,0	-
SPC375-10	10	375	384,6	3	4545	110	-	264	316	75,0	114	75,0	-
SPC400-10	10	400	409,6	6	5050	125	70	264	344	68,5	127	68,5	267
SPC450-10	10	450	459,6	6	5050	125	40	264	394	68,5	127	68,5	267
SPC500-10	10	500	509,6	6	5050	125	40	264	444	68,5	127	68,5	267
SPC560-10	10	560	569,6	5	5050	125	-	264	504	68,5	127	68,5	267
SPC630-10	10	630	639,6	5	5050	125	-	264	574	68,5	127	68,5	267
SPC710-10	10	710	719,6	5	5050	125	-	264	654	68,5	127	68,5	267
SPC800-10	10	800	809,6	5	5050	125	-	264	737	68,5	127	68,5	267
SPC1000-10	10	1000	1009,6	5	5050	125	-	264	937	68,5	127	68,5	267
SPC1250-10	10	1250	1259,6	5	5050	125	-	264	1187	68,5	127	68,5	267

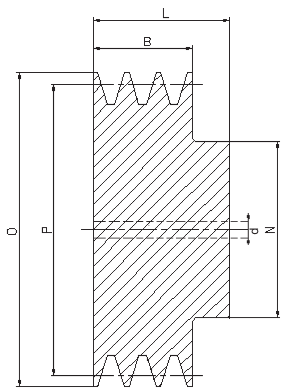
PULEGGE TRAPEZOIDALI MONOBLOCCO
V-BELT PULLEYS WITH SOLID HUB



FORMA FORM



1

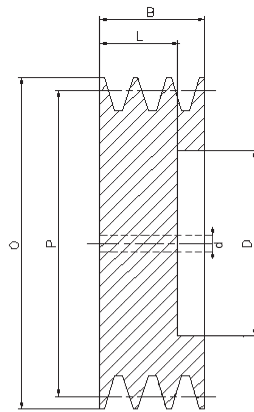

2

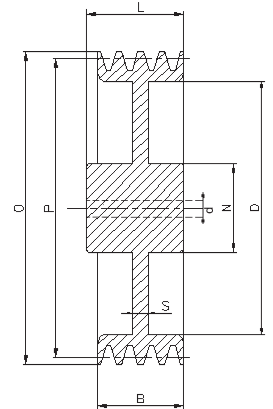

3

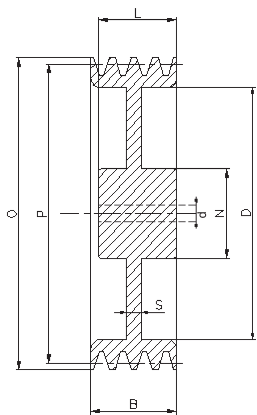

4

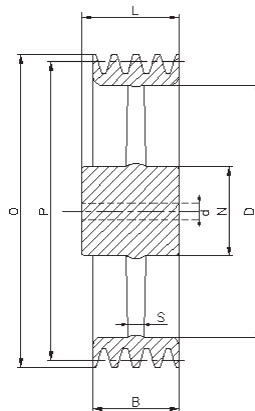

5

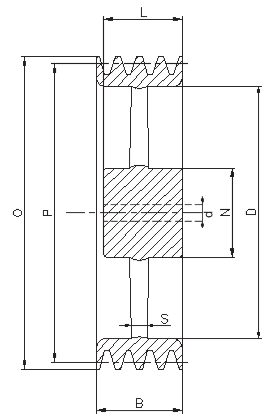

6

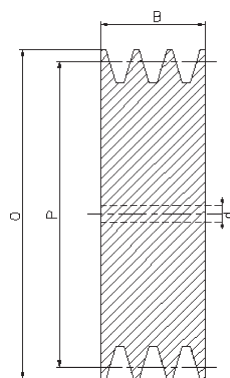

7

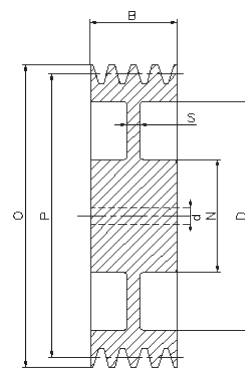

8

SPZ

Descrizione Description Beschreibung Description Descripción	P	O	Gole Grooves Rillen Gorges Canales	N	L	D	S	B	Forma Form Forme Forme Forma	d	Peso Weight Gewicht Poids Peso
SPZ50	50	54	1	40	28			16	1	10	
			2	40	35			28	1	10	
			3					40	7	10	
SPZ56	56	60	1	45	28			16	1	10	
			2	45	35			28	1	10	
			3					40	7	10	
SPZ63	63	67	1	50	28			16	1	10	
			2	50	35			28	1	10	
			3					40	7	10	
SPZ71	71	75	1	50	28			16	1	10	
			2	55	35			28	1	10	
			3					40	7	10	
SPZ75	75	79	1	50	28			16	1	10	
			2	60	35			28	1	10	
			3					40	7	10	
SPZ80	80	84	1	50	28			16	1	10	
			2	60	35			28	1	10	
			3					40	7	10	
SPZ85	85	89	1	50	28			16	1	10	
			2	60	35			28	1	10	
			3					40	7	15	
SPZ90	90	94	1	50	28			16	1	10	
			2	60	35			28	1	10	
			3					40	7	15	
SPZ95	95	99	1	50	28			16	1	10	
			2	60	35			28	1	15	
			3					40	7	15	
SPZ100	100	104	1	50	28			16	1	10	
			2	60	35			28	1	15	
			3					40	7	15	
SPZ106	106	110	1	50	28			16	1	10	
			2	60	35			28	1	15	
			3					40	7	15	
SPZ112	112	116	1	50	28			16	1	10	
			2	60	35			28	1	15	
			3					40	7	15	
SPZ118	118	122	1	50	28	93	8	16	3	10	
			2	60	35	91	8	28	3	15	
			3					40	7	15	
SPZ125	125	129	1	50	28	100	8	16	3	15	
			2	60	35	99	8	28	3	15	
			3					40	7	15	

SPZ

Descrizione Description Beschreibung Description Descripción	P	O	Gole Grooves Rillen Gorges Canales	N	L	D	S	B	Forma Form Forme Forme Forma	d	Peso Weight Gewicht Poids Peso
SPZ132	132	136	1	50	28	106	8	16	3	15	
			2	60	40	106	8	28	3	15	
			3	60	40	106	8	40	8	15	
SPZ140	140	144	1	50	28	114	8	16	3	15	
			2	60	40	114	8	28	3	15	
			3	60	40	114	8	40	8	15	
SPZ150	150	154	1	50	28	124	8	16	3	15	
			2	60	40	124	8	28	3	15	
			3	60	40	124	8	40	8	20	
SPZ160	160	164	1	55	32	134	8	16	3	15	
			2	60	40	134	8	28	3	15	
			3	65	45	134	8	40	3	20	
SPZ180	180	184	1	55	32	154	8	16	5	20	
			2	60	40	154	8	28	5	20	
			3	65	45	154	8	40	5	20	
SPZ200	200	204	1	55	32	174	8	16	5	20	
			2	60	40	174	8	28	5	20	
			3	65	45	174	10	40	5	20	
SPZ224	224	228	1	55	32	198	8	16	5	20	
			2	60	40	198	8	28	5	20	
			3	65	45	198	10	40	5	20	
SPZ250	250	254	1	55	32	224	8	16	5	20	
			2	60	40	224	10	28	5	20	
			3	65	45	224	12	40	5	20	
SPZ280	280	284	2	65	45	254	10	28	5	20	
SPZ315	315	319	2	65	45	289	10	28	5	20	

SPA

Descrizione Description Beschreibung Description Descripción	P	O	Gole Grooves Rillen Gorges Canales	N	L	D	S	B	Forma Form Forme Forme Forma	d	Peso Weight Gewicht Poids Peso
SPA40	40	45,5	1	40	35			20	1	10	
SPA50	50	55,5	1	40	35			20	1	10	
			2	40	45			35	1	10	
SPA56	56	61,5	1	40	35			20	1	10	
			2	40	45			35	1	10	
			3					50	7	10	
SPA60	60	65,5	3					50	7	10	
SPA63	63	68,5	1	40	35			20	1	10	
			2	40	45			35	1	10	
			3					50	7	10	
SPA71	71	76,5	1	40	40			20	1	10	
			2	50	45			35	1	10	
			3					50	7	10	
SPA75	75	80,5	1	40	40			20	1	10	
			2	50	45			35	1	10	
			3					50	7	10	
			4					65	7	10	
			5					80	7	10	
SPA80	80	85,5	1	45	40			20	1	10	
			2	50	45			35	1	10	
			3					50	7	15	
			4					65	7	15	
			5					80	7	15	
SPA85	85	90,5	1	45	40			20	1	10	
			2	50	45			35	1	10	
			3					50	7	15	
			4					65	7	15	
			5					80	7	15	
SPA90	90	95,5	1	45	40			20	1	10	
			2	60	45			35	1	15	
			3					50	7	15	
			4					65	7	15	
			5					80	7	15	
SPA95	95	100,5	1	45	40			20	1	10	
			2	60	45			35	1	15	
			3					50	7	15	
			4					65	7	15	
			5					80	7	15	
SPA100	100	105,5	1	48	40			20	1	10	
			2	60	45			35	1	15	
			3					50	7	15	
			4		52	67		65	2	15	
			5		52	67		80	2	15	
SPA106	106	111,5	1	48	40			20	1	10	
			2	60	45			35	1	15	
			3					50	7	15	
			5		52	67		80	2	15	
SPA112	112	117,5	1	48	40			20	1	10	
			2	60	45			35	1	15	
			3					50	7	15	
			4		52	79		65	2	15	
			5		52	79		80	2	15	
SPA118	118	123,5	1	60	40			20	1	15	
			2	60	45			35	1	15	
			3					50	7	15	
			4		52	87		65	2	15	
			5		52	87		80	2	15	

SPA

Descrizione Description Beschreibung Description Descripción	P	O	Gole Grooves Rillen Gorges Canales	N	L	D	S	B	Forma Form Forme Forme Forma	d	Peso Weight Gewicht Poids Peso
SPA125	125	130,5	1	60	40			20	1	15	
			2	60	45			35	1	15	
			3					50	7	15	
			4		52	97		65	2	15	
SPA132	132	137,5	1	60	40			20	1	15	
			2	60	45			35	1	15	
			3					50	7	15	
			4		52	97		65	2	15	
			5		52	97		80	2	15	
SPA140	140	145,5	1	60	40	107	10	20	3	15	
			2	60	45	107	10	35	3	15	
			3	65	52	107	18	50	3	20	
			4		52	107		65	2	20	
			5		52	107		80	2	20	
SPA150	150	155,5	1	60	40	117	10	20	3	15	
			2	60	45	117	10	35	3	15	
			3	65	52	117	18	50	3	20	
			4		52	117		65	2	20	
			5		52	117		80	2	20	
SPA160	160	165,5	1	60	40	127	10	20	3	15	
			2	60	45	127	10	35	3	15	
			3	70	52	127	18	50	3	20	
			4	70	52	127	22	65	4	20	
			5	80	52	127	22	80	4	20	
SPA170	170	175,5	1	60	40	137	10	20	3	15	
			2	60	45	137	10	35	3	15	
			3	70	52	137	18	50	3	20	
			4	80	52	137	18	65	4	20	
			5	80	52	137	18	80	4	20	
SPA180	180	185,5	1	65	40	147	10	20	3	20	
			2	70	50	147	12	35	3	20	
			3	70	52	147	12	50	3	20	
			4	80	60	147	22	65	4	20	
			5	80	65	147	22	80	4	20	
SPA190	190	195,5	2	70	50	157	12	35	3	20	
			3	70	52	157	12	50	3	20	
			4	80	60	157	18	65	4	20	
SPA200	200	205,5	1	65	45	167	10	20	3	20	
			2	70	50	167	12	35	3	20	
			3	70	52	167	12	50	3	20	
			4	80	60	167	18	65	4	20	
			5	80	65	167	20	80	4	20	
SPA212	212	217,5	1	65	40		10	20	3	20	
			2	70	45		12	35	3	20	
SPA224	224	229,5	1	65	45	192	10	20	3	20	
			2	70	50	192	12	35	3	20	
			3	80	52	192	12	50	3	20	
			4	90	60	192	18	65	4	20	
			5	90	65	192	20	80	4	20	
SPA236	236	241,5	1		50		12	20	3	20	
			2		50		12	35	3	20	
SPA250	250	255,5	1	75	50	217	12	20	3	20	
			2	75	50	217	12	35	3	20	
			3	80	60	217	12	50	3	20	
			4	90	65	217	18	65	3	20	
			5	90	65	217	20	80	4	20	
SPA280	280	285,5	1	75	50	247	14	20	5	20	
			2	80	50	247	14	35	5	20	
			3	80	60	247	14	50	5	20	
			4	90	65	247	16	65	5	20	
			5	100	65	247	18	80	6	25	

SPA

Descrizione Description Beschreibung Description Descripción	P	O	Gole Grooves Rillen Gorges Canales	N	L	D	S	B	Forma Form Forme Forme Forma	d	Peso Weight Gewicht Poids Peso
SPA300	300	305,5	1	75	50	267	14	20	5	20	
			2	80	50	267	14	35	5	20	
			3	80	60	267	14	50	5	20	
			4	90	65	267	16	65	5	20	
			5	100	65	267	18	80	6	25	
SPA315	315	320,5	1	75	60	282	14	20	5	20	
			2	80	50	282	14	35	5	20	
			3	90	60	282	14	50	5	20	
			4	90	65	282	16	65	5	20	
			5	100	65	282	18	80	6	25	
SPA355	355	360,5	1	75	50	322	14	20	5	20	
			2	80	50	322	14	35	5	20	
			3	90	60	322	14	50	5	20	
			4	90	65	322	16	65	5	25	
			5	100	65	322	18	80	6	25	
SPA400	400	405,5	1	90	50	367	14	20	5	20	
			2	90	50	367	14	35	5	20	
			3	100	60	367	16	50	5	25	
			4	100	65	367	20	65	5	25	
			5	100	65	367	22	80	6	25	
SPA450	450	455,5	1	90	50	417	14	20	5	20	
			2	100	50	417	14	35	5	25	
			3	100	60	417	16	50	5	25	
			4	105	65	417	20	65	6	25	
			5	105	65	417	22	80	6	25	
SPA500	500	505,5	1	90	50	467	14	20	5	20	
			2	100	50	467	16	35	5	25	
			3	105	60	467	20	50	5	25	
			4	105	65	467	20	65	6	25	
			5	110	65	467	22	80	6	25	
SPA560	560	565,5	1	100	50	527	15	20	5	25	
			2	100	50	527	18	35	5	25	
			3	120	65	527	20	50	5	25	
			4	120	65	527	22	65	5	25	
			5	120	80	527	24	80	5	25	
			6	120	80	527	26	95	6	25	
SPA630	630	635,5	1	100	50	597	16	20	5	25	
			2	110	50	597	18	35	5	25	
			3	120	65	597	20	50	5	25	
			4	120	65	597	22	65	5	25	
			5	120	80	597	24	80	5	25	
			6	120	80	597	26	95	6	25	

Descrizione Description Beschreibung Description Descripción	P	O	Gole Grooves Rillen Gorges Canales	N	L	D	S	B	Forma Form Forme Forme Forma	d	Peso Weight Gewicht Poids Peso
SPB63	63	70	1	45	45			25	1	10	
SPB70	70	77	1	45	45			25	1	10	
			2	45	55			44	1	10	
SPB71	71	78	3					63	7	15	
SPB80	80	87	1	50	45			25	1	10	
			2	50	55			44	1	10	
			3					63	7	15	
			4					82	7	15	
			5					101	7	15	
SPB85	85	92	1	50	45			25	1	10	
			2	50	55			44	1	10	
			3	-	-			63	7	15	
SPB90	90	97	1	50	45			25	1	10	
			2	50	55			44	1	10	
			3					63	7	15	
			4					82	7	15	
			5					101	7	15	
SPB95	95	102	1	50	45			25	1	10	
SPB100	100	107	1	52	45			25	1	10	
			2	55	55			44	1	15	
			3					63	7	15	
			4					82	7	15	
			5					101	7	15	
SPB106	106	113	1		45			25	1	15	
			2		55			44	1	15	
SPB112	112	119	1	55	45			25	1	15	
			2	60	55			44	1	15	
			3					63	7	15	
			4					82	7	20	
			5					101	7	20	
SPB118	118	125	1	55	45			25	1	15	
			2	60	55			44	1	15	
			3					63	7	15	
			4					82	7	20	
			5					101	7	20	
			6					120	7	20	
SPB120	120	127	1	55	45			25	1	15	
			2	60	55			44	1	15	
			3					63	7	15	
			4					82	7	20	
			5					101	7	20	
			6					120	7	20	
SPB125	125	132	1	58	45			25	1	10	
			2	60	55			44	1	15	
			3		60	83		63	2	15	
			4		60	83		82	2	20	
			5		60	83		101	2	20	
			6		60	83		120	2	20	
SPB132	132	139	1	60	45			25	1	15	
			2	60	55			44	1	15	
			3		60	88		63	2	15	
			4		60	88		82	2	20	
			5		60	88		101	2	20	
			6		60	88		120	2	20	
SPB140	140	147	1	65	45			25	1	20	
			2	65	55			44	1	20	
			3		60	98		63	2	20	
			4		60	98		82	2	20	
			5		60	98		101	2	20	
			6		60	98		120	2	20	
SPB150	150	157	1	65	45			25	1	20	
			2	65	55			44	1	20	
			3		60	108		63	2	20	
			4		60	108		82	2	20	
			5		60	108		101	2	20	
			6		60	108		120	2	20	

Descrizione Description Beschreibung Description Descripción	P	O	Gole Grooves Rillen Gorges Canales	N	L	D	S	B	Forma Form Forme Forme Forma	d	Peso Weight Poids Peso
SPB160	160	167	1	65	45	118	12	25	3	20	
			2	70	55	118	12	44	3	20	
			3		60	118		63	2	20	
			4		60	118		82	2	20	
			5		60	118		101	2	20	
			6		65	118		120	2	20	
SPB170	170	177	1	65	45	128	12	25	3	20	
			2	70	55	128	12	44	3	20	
			3	70	60	128	30	63	4	20	
			4	70	60	128	30	82	4	20	
			5	70	60	128	30	101	4	20	
			6	70	65	128	40	120	4	20	
SPB180	180	187	1	65	45	138	12	25	3	20	
			2	70	55	138	12	44	3	20	
			3	80	60	138	18	63	4	20	
			4	80	60	138	30	82	4	20	
			5	80	70	138	40	101	4	20	
			6	80	70	138	40	120	4	20	
SPB190	190	197	1	65	45	148	12	25	3	20	
			2	70	55	148	12	44	3	20	
SPB200	200	207	1	70	45	158	14	25	3	20	
			2	70	55	158	12	44	3	20	
			3	80	60	158	18	63	4	20	
			4	88	60	158	25	82	4	20	
			5	96	70	158	35	101	4	25	
			6	96	70	158	40	120	4	25	
SPB212	212	219	1	70	45	170	14	25	3	20	
			2	77	55	170	14	44	3	20	
			3	80	60	170	18	63	4	20	
			4	88	60	170	25	82	4	20	
			5	96	70	170	30	101	4	25	
			6	104	80	170	45	120	4	25	
SPB224	224	231	1	70	45	183	14	25	3	20	
			2	77	55	183	14	44	3	20	
			3	80	60	183	18	63	4	20	
			4	88	60	183	25	82	4	20	
			5	96	70	183	25	101	4	25	
			6	104	80	183	30	120	4	25	
SPB250	250	257	1	70	50	208	14	25	3	20	
			2	77	55	208	14	44	3	20	
			3	80	60	208	18	63	4	20	
			4	96	65	208	25	82	4	25	
			5	104	75	208	25	101	4	25	
			6	104	80	208	25	120	4	25	
SPB280	280	287	1	76	50	238	14	25	3	20	
			2	80	55	238	14	44	3	20	
			3	90	60	238	18	63	4	20	
			4	96	65	238	25	82	4	25	
			5	104	75	238	25	101	4	25	
			6	104	80	238	25	120	4	25	
SPB300	300	307	1	76	50	258	15	25	5	20	
			2	80	55	258	15	44	5	20	
			3	90	60	258	18	63	6	20	
			4	96	65	258	20	82	6	25	
			5	104	75	258	22	101	6	25	
			6	104	80	258	24	120	6	25	

Descrizione Description Beschreibung Description Descripción	P	O	Gole Grooves Rillen Gorges Canales	N	L	D	S	B	Forma Form Forme Forme Forma	d	Peso Weight Gewicht Poids Peso
SPB315	315	322	1	76	50	273	15	25	5	20	
			2	88	60	273	15	44	5	20	
			3	90	60	273	18	63	6	20	
			4	96	65	273	20	82	6	25	
			5	104	75	273	22	101	6	25	
			6	120	90	273	24	120	6	25	
SPB355	355	362	1	80	50	313	15	25	5	20	
			2	88	60	313	15	44	5	20	
			3	92	60	313	18	63	6	25	
			4	96	65	313	20	82	6	25	
			5	104	75	313	22	101	6	25	
			6	120	90	313	24	120	6	25	
SPB400	400	407	1	85	55	358	18	25	5	20	
			2	88	60	358	18	44	5	20	
			3	96	65	358	22	63	5	25	
			4	104	75	358	24	82	6	25	
			5	112	85	358	26	101	6	25	
			6	120	100	358	28	120	6	25	
SPB425	425	432	3	96	65	383	22	63	5	20	
			4	104	75	383	24	82	6	25	
			5	112	85	383	26	101	6	25	
SPB450	450	457	1	90	60	408	18	25	5	20	
			2	90	60	408	18	44	5	20	
			3	96	65	408	22	63	5	25	
			4	104	75	408	24	82	6	25	
			5	112	85	408	26	101	6	25	
			6	120	100	408	28	120	6	25	
SPB500	500	507	1	100	60	458	18	25	5	25	
			2	100	65	458	20	44	5	25	
			3	104	75	458	24	63	5	25	
			4	112	85	458	28	82	5	25	
			5	120	90	458	30	101	6	25	
			6	128	105	458	33	120	6	25	
SPB560	560	567	1	100	60	518	18	25	5	25	
			2	100	65	518	20	44	5	25	
			3	104	75	518	24	63	5	25	
			4	112	85	518	28	82	5	25	
			5	120	90	518	30	101	6	25	
			6	128	105	518	33	120	6	25	
SPB600	600	607	1	100	60	558	18	25	5	25	
			2	100	65	558	20	44	5	25	
			3	104	75	558	24	63	5	25	
			4	115	85	558	28	82	5	25	
			5	120	90	558	30	101	6	25	
			6	129	105	558	33	120	6	25	
SPB630	630	637	1	100	60	588	18	25	5	25	
			2	100	65	588	20	44	5	25	
			3	105	75	588	26	63	5	25	
			4	120	85	588	28	82	5	25	
			5	128	90	588	30	101	6	25	
			6	140	105	588	33	120	6	25	

Descrizione Description Beschreibung Description Descripción	P	O	Gole Grooves Rillen Gorges Canales	N	L	D	S	B	Forma Form Forme Forme Forma	d	Peso Weight Gewicht Poids Peso
SPC100	100	109,6	1	60	50			34,0	1	15	
SPC120	120	129,6	1	65	50			34,0	1	15	
			2					59,5	7	15	
SPC140	140	149,6	1	70	50			34,0	1	20	
			2					59,5	7	20	
			3		65	83		85,0	2	20	
			4		80	83		110,5	2	20	
SPC150	150	159,6	1	70	50			34,0	1	20	
			2					59,5	7	20	
			3		65	93		85,0	2	20	
			4		80	93		110,5	2	20	
			5		96	93		136,0	2	20	
SPC160	160	169,6	1	72	50	103		34,0	1	20	
			2			103		59,5	7	20	
			3		65	103		85,0	2	20	
			4		80	103		110,5	2	20	
			5		96	103		136,0	2	20	
			6		96	103		161,5	2	20	
SPC180	180	189,6	1	76	50	123	16	34,0	3	20	
			2	80		123	30	59,5	8	20	
			3	82	65	123	35	85,0	4	20	
			4	82	80	123	60	110,5	4	20	
			5	82	96	123	75	136,0	4	20	
			6	82	96	123	75	161,5	4	20	
SPC200	200	209,6	1	76	50	143	16	34,0	3	20	
			2	80	60	143	20	59,5	3	20	
			3	86	65	143	25	85,0	4	20	
			4	90	90	143	70	110,5	4	20	
			5	90	100	143	80	136,0	4	25	
			6	90	100	143	80	161,5	4	25	
SPC224	224	233,6	1	86	50	168	16	34,0	3	20	
			2	88	60	168	18	59,5	3	20	
			3	90	70	168	21	85,0	4	20	
			4	90	90	168	50	110,5	4	25	
			5	90	100	168	60	136,0	4	25	
			6	90	100	168	60	161,5	4	25	
SPC250	250	259,6	1	86	50	193	16	34,0	3	20	
			2	92	60	193	18	59,5	3	20	
			3	92	70	193	21	85,0	4	20	
			4	100	90	193	30	110,5	4	25	
			5	102	100	193	50	136,0	4	25	
			6	102	100	193	50	161,5	4	25	
SPC280	280	289,6	1	86	50	223	16	34,0	3	20	
			2	92	60	223	18	59,5	3	20	
			3	92	70	223	21	85,0	4	20	
			4	100	90	223	25	110,5	4	25	
			5	102	100	223	40	136,0	4	25	
			6	102	100	223	40	161,5	4	25	
SPC300	300	309,6	1	86	50	243	16	34,0	3	20	
			2	92	60	243	18	59,5	3	20	
			3	92	70	243	21	85,0	4	20	
			4	100	90	243	25	110,5	4	25	
			5	104	100	243	25	136,0	4	25	
			6	104	100	243	25	161,5	4	25	

SPC

Descrizione Description Beschreibung Description Descripción	P	O	Gole Grooves Rillen Gorges Canales	N	L	D	S	B	Forma Form Forme Forme Forma	d	Peso Weight Gewicht Poids Peso
SPC315	315	324,6	1	92	50	258	16	34,0	5	20	
			2	92	60	258	18	59,5	5	20	
			3	92	70	258	22	85,0	6	25	
			4	110	90	258	25	110,5	4	25	
			5	112	100	258	25	136,0	4	25	
			6	112	100	258	28	161,5	4	25	
SPC335	335	344,6	1	100	50	283	16	34,0	5	20	
			2	100	60	283	18	59,5	5	20	
			3	100	70	283	22	85,0	6	25	
			4	114	90	283	25	110,5	6	25	
			5	114	100	283	28	136,0	6	25	
			6	114	100	283	30	161,5	6	25	
SPC355	355	364,6	1	110	50	298	16	34,0	5	20	
			2	110	60	298	18	59,5	5	25	
			3	110	70	298	22	85,0	6	25	
			4	114	90	298	25	110,5	6	25	
			5	114	100	298	28	136,0	6	25	
			6	114	100	298	30	161,5	6	25	
SPC400	400	409,6	1	110	60	343	18	34,0	5	25	
			2	110	70	343	20	59,5	5	25	
			3	114	90	343	24	85,0	5	25	
			4	114	90	343	26	110,5	6	25	
			5	120	100	343	28	136,0	6	25	
			6	120	100	343	30	161,5	6	25	
SPC450	450	459,6	1	110	60	393	18	34,0	5	25	
			2	110	70	393	20	59,5	5	25	
			3	114	90	393	24	85,0	5	25	
			4	120	90	393	28	110,5	6	25	
			5	120	100	393	30	136,0	6	25	
			6	120	100	393	32	161,5	6	25	
SPC500	500	509,6	1	114	60	443	18	34,0	5	25	
			2	114	70	443	20	59,5	5	25	
			3	114	90	443	24	85,0	5	25	
			4	126	90	443	28	110,5	6	25	
			5	126	100	443	30	136,0	6	25	
			6	126	100	443	32	161,5	6	25	
SPC560	560	569,6	1	114	60	503	20	34,0	5	25	
			2	114	70	503	24	59,5	5	25	
			3	114	90	503	28	85,0	5	25	
			4	130	100	503	30	110,5	6	25	
			5	130	100	503	32	136,0	6	25	
			6	130	100	503	35	161,5	6	25	
SPC600	600	609,6	1	114	60	543	20	34,0	5	25	
			2	114	70	543	24	59,5	5	25	
			3	114	90	543	28	85,0	5	25	
			4	130	90	543	30	110,5	6	25	
			5	130	100	543	32	136,0	6	25	
			6	130	100	543	35	161,5	6	25	
SPC630	630	639,6	1	114	60	573	20	34,0	5	25	
			2	114	70	573	24	59,5	5	25	
			3	114	90	573	28	85,0	5	25	
			4	130	90	573	30	110,5	6	25	
			5	130	100	573	32	136,0	6	25	
			6	130	100	573	35	161,5	6	25	

**PULEGGE TRAPEZOIDALI PER CALETTATORE
V-BELT PULLEYS FOR LOCKING DEVICES**



PULEGGE TRAPEZOIDALI PER CALETTATORE V-BELT PULLEYS FOR LOCKING DEVICES

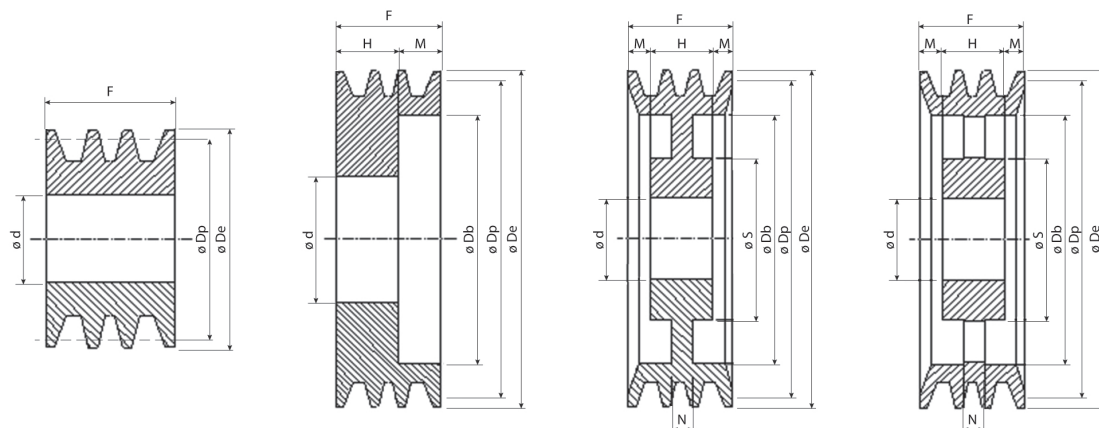

SPA

1

2

3

4

Cod. Interno / Internal code Intern Code / Code interne Código interno	Dp	De	Gole / Grooves Rillen / Gorges Canales	Forma / Form Forme / Forme Forma	** ØdH8			F	H	Ø S	M	Ø Db	N
					Ø 55	Ø 65	Ø 80						
AK0090155	90	95,5	1	1	55			20					
AK0090255			2	1	55			35					
AK0090355			3	1	55			50					
AK0090455			4	1	55			65					
AK0090555			5	1	55			80					
AK0095155	95	100,5	1	1	55			20					
AK0095255			2	1	55			35					
AK0095355			3	1	55			50					
AK0095455			4	1	55			65					
AK0095555			5	1	55			80					
AK01001**	100	105,5	1	1	55	65		20					
AK01002**			2	1	55	65		35					
AK01003**			3	1	55	65		50					
AK01004**			4	1	55	65		65					
AK01005**			5	1	55	65		80					
AK01051**	105	110,5	1	1	55	65		20					
AK01052**			2	1	55	65		35					
AK01053**			3	1	55	65		50					
AK01054**			4	1	55	65		65					
AK01055**			5	1	55	65		80					
AK01121**	112	117,5	1	1	55	65		20					
AK01122**			2	2	55	65		35	27		8	79	
AK01123**			3	2	55	65		50	27		23	79	
AK01124**			4	2	55	65		65	27		38	79	
AK01125**			5	3	55	65		80	27		26,5	79	27
AK01201**	120	125,5	1	1	55	65	80	20					
AK01202**			2	2	55	65	80	35	27		8	88	
AK01203**			3	2	55	65	80	50	27		23	88	
AK01204**			4	2	55	65	80	65	27		38	88	
AK01205**			5	3	55	65	80	80	27		26,5	88	27
AK01251**	125	130,5	1	1	55	65	80	20					
AK01252**			2	2	55	65	80	35	27		8	92	
AK01253**			3	2	55	65	80	50	27		23	92	
AK01254**			4	2	55	65	80	65	27		38	92	
AK01255**			5	3	55	65	80	80	27		26,5	92	27
AK01301**	130	135,5	1	1	55	65	80	20					
AK01302**			2	2	55	65	80	35	27		8	97	
AK01303**			3	2	55	65	80	50	27		23	97	
AK01304**			4	2	55	65	80	65	27		38	97	
AK01305**			5	3	55	65	80	80	27		26,5	97	27
AK01401**	140	145,5	1	1	55	65	80	20					
AK01402**			2	2	55	65	80	35	27		8	107	
AK01403**			3	2	55	65	80	50	27		23	107	
AK01404**			4	2	55	65	80	65	27		38	107	
AK01405**			5	3	55	65	80	80	27		26,5	107	27

** = Diametro del foro della puleggia (sede per calettatore) / Pulley bore diameter (seat for locking device) / Scheibenbohrungsdurchmesser (Sitz für Spannsatz)

Diamètre de l'alésage de la poulie (logement pour moyeu de serrage) / Diámetro del agujero de la polea (sede para casquillo de fijación)

PULEGGE TRAPEZOIDALI PER CALETTATORE V-BELT PULLEYS FOR LOCKING DEVICES

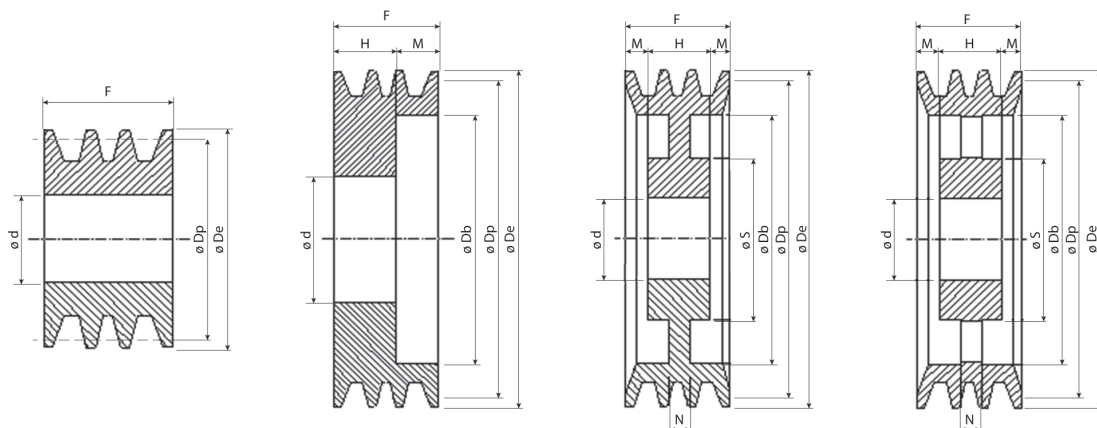

SPA

1

2

3

4

Cod. Interno / Internal code Intern Code / Code interne Código interno	Dp	De	Gole / Grooves Rillen / Gorges Canales	Forma / Form Forme / Forme Forma	** ØdH8			F	H	Ø S	M	Ø Db	N
					Ø 55	Ø 65	Ø 80						
AK01501**	150	155,5	1	1	55	65	80	20					
AK01502**			2	2	55	65	80	35	27		8	117	
AK01503**			3	2	55	65	80	50	27		23	117	
AK01504**			4	2	55	65	80	65	27		38	117	
AK01505**			5	3	55	65	80	80	27		26,5	117	27
AK01601**	160	165,5	1	1	55	65	80	20					
AK01602**			2	2	55	65	80	35	27		8	127	
AK01603**			3	2	55	65	80	50	27		23	127	
AK01604**			4	2	55	65	80	65	27		38	127	
AK01605**			5	3	55	65	80	80	27		26,5	127	27
AK01701**	170	175,5	1	1	55	65	80	20					
AK01702**			2	3	55	65	80	35	27		4	137	27
AK01703**			3	3	55	65	80	50	27		11,5	137	27
AK01704**			4	3	55	65	80	65	27		19	137	27
AK01705**			5	3	55	65	80	80	27		26,5	137	27
AK01801**	180	185,5	1	1	55	65	80	20					
AK01802**			2	3	55	65	80	35	27		4	147	27
AK01803**			3	3	55	65	80	50	27		11,5	147	27
AK01804**			4	3	55	65	80	65	27		19	147	27
AK01805**			5	3	55	65	80	80	27		26,5	147	27
AK01901**	190	195,5	1	1	55	65	80	20					
AK01902**			2	3	55	65	80	35	27	120	4	157	12
AK01903**			3	3	55	65	80	50	27	120	11,5	157	12
AK01904**			4	3	55	65	80	65	27	120	19	157	12
AK01905**			5	3	55	65	80	80	27	120	26,5	157	12
AK02001**	200	205,5	1	1	55	65	80	20					
AK02002**			2	3	55	65	80	35	27	120	4	167	12
AK02003**			3	3	55	65	80	50	27	120	11,5	167	14
AK02004**			4	3	55	65	80	65	27	120	19	167	14
AK02005**			5	3	55	65	80	80	27	120	26,5	167	14
AK02251**	225	230,5	1	3	55	65	80	20	20	120		192	12
AK02252**			2	3	55	65	80	35	27	120	4	192	12
AK02253**			3	3	55	65	80	50	27	120	11,5	192	14
AK02254**			4	3		65	80	65	27	120	19	192	14
AK02255**			5	3		65	80	80	27	120	26,5	192	14
AK02501**	250	255,5	1	4	55	65	80	20	20	130		217	14
AK02502**			2	4	55	65	80	35	27	130	4	217	14
AK02503**			3	4	55	65	80	50	27	130	11,5	217	14
AK02504**			4	4		65	80	65	27	130	19	217	14
AK02505**			5	4		65	80	80	27	130	26,5	217	14
AK02801**	280	285,5	1	4	55	65	80	20	20	130		247	14
AK02802**			2	4	55	65	80	35	27	130	4	247	14
AK02803**			3	4	55	65	80	50	27	130	11,5	247	14
AK02804**			4	4		65	80	65	27	130	19	247	14
AK02805**			5	4		65	80	80	27	130	26,5	247	14

** = Diametro del foro della puleggia (sede per calettatore) / Pulley bore diameter (seat for locking device) / Scheibenbohrungsdurchmesser (Sitz für Spannsatz)

Diamètre de l'alésage de la poulie (logement pour moyeu de serrage) / Diámetro del agujero de la polea (sede para casquillo de fijación)

PULEGGE TRAPEZOIDALI PER CALETTATORE V-BELT PULLEYS FOR LOCKING DEVICES

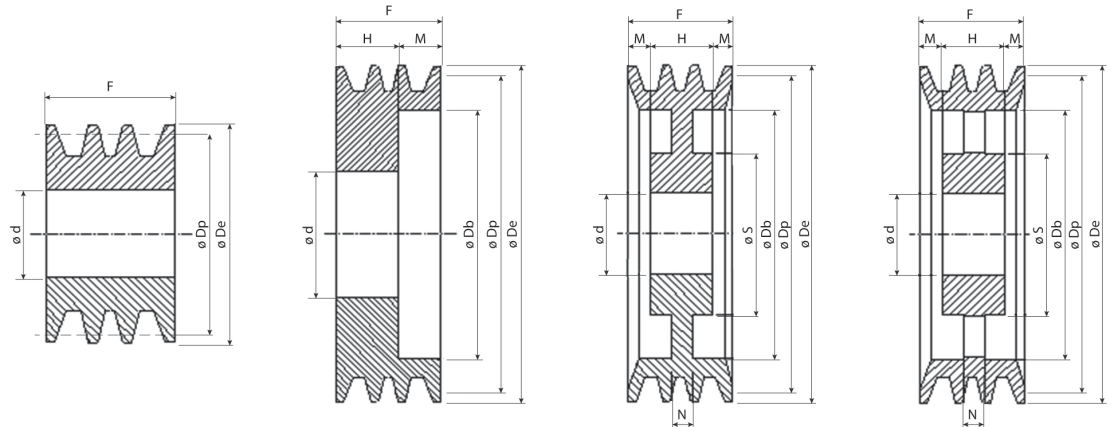

SPA

1

2

3

4

Cod. Interno / Internal code Interner Code / Code interne Código interno	Dp	De	Gole / Grooves Rillen / Gorges Canales	Forma / Form Forme / Forme Forma	** ØdH8			F	H	Ø S	M	Ø Db	N
					Ø 55	Ø 65	Ø 80						
AK03001**	300	305,5	1	4	55	65	80	20	20	130		267	14
AK03002**			2	4	55	65	80	35	27	130	4	267	14
AK03003**			3	4	55	65	80	50	27	130	11,5	267	14
AK03004**			4	4	65	80	65	27	130	19	267	14	
AK03005**			5	4	65	80	80	27	130	26,5	267	14	
AK03151**	315	320,5	1	4	55	65	80	20	20	130		282	14
AK03152**			2	4	55	65	80	35	27	130	4	282	14
AK03153**			3	4	55	65	80	50	27	130	11,5	282	14
AK03154**			4	4	65	80	65	27	130	19	282	14	
AK03155**			5	4	65	80	80	27	130	26,5	282	16	
AK03551**	355	360,5	1	4	55	65	80	20	20	130		317	14
AK03552**			2	4	55	65	80	35	27	130	4	317	14
AK03553**			3	4	55	65	80	50	27	130	11,5	317	14
AK03554**			4	4	65	80	65	27	130	19	317	18	
AK03555**			5	4	65	80	80	27	130	26,5	317	20	
AK03801**	380	385,5	1	4		65	80	20	20	130		347	14
AK03802**			2	4		65	80	35	27	130	4	347	14
AK03803**			3	4		65	80	50	27	130	11,5	347	14
AK03804**			4	4		65	80	65	27	130	19	347	18
AK03805**			5	4		65	80	80	27	130	26,5	347	20
AK04001**	400	405,5	1	4		65	80	20	20	130		367	14
AK04002**			2	4		65	80	35	27	130	4	367	14
AK04003**			3	4		65	80	50	27	130	11,5	367	16
AK04004**			4	4		65	80	65	27	130	19	367	20
AK04005**			5	4		65	80	80	27	130	26,5	367	24
AK04251**	425	430,5	1	4		65	80	20	20	130		392	14
AK04252**			2	4		65	80	35	27	130	4	392	14
AK04253**			3	4		65	80	50	27	130	11,5	392	16
AK04254**			4	4		65	80	65	27	130	19	392	20
AK04255**			5	4		65	80	80	27	130	26,5	392	24
AK04501**	450	455,5	1	4		65	80	20	20	130		417	14
AK04502**			2	4		65	80	35	27	130	4	417	14
AK04503**			3	4		65	80	50	27	130	11,5	417	16
AK04504**			4	4		65	80	65	27	130	19	417	20
AK04505**			5	4		65	80	80	27	130	26,5	417	24
AK05001**	500	505,5	1	4		65	80	20	20	130		467	14
AK05002**			2	4		65	80	35	27	130	4	467	16
AK05003**			3	4		65	80	50	27	130	11,5	467	20
AK05004**			4	4		65	80	65	27	130	19	467	25
AK05005**			5	4		65	80	80	27	130	26,5	467	25
AK06301**	630	635,5	1	4		65	80	20	20	130		597	16
AK06302**			2	4		65	80	35	27	130	4	597	20
AK06303**			3	4		65	80	50	27	130	11,5	597	22
AK06304**			4	4		65	80	65	27	130	19	597	25
AK06305**			5	4		65	80	80	27	130	26,5	597	25

** = Diametro del foro della puleggia (sede per calettatore) / Pulley bore diameter (seat for locking device) / Scheibenbohrungsdurchmesser (Sitz für Spannsatz)

Diamètre de l'alésage de la poulie (logement pour moyeu de serrage) / Diámetro del agujero de la polea (sede para casquillo de fijación)

PULEGGE TRAPEZOIDALI PER CALETTATORE V-BELT PULLEYS FOR LOCKING DEVICES

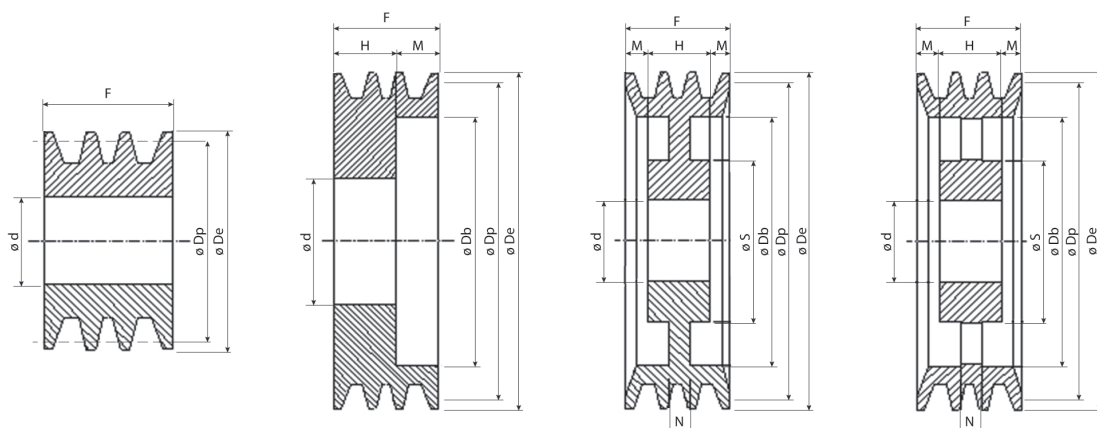

SPB

1

2

3

4

Cod. Interno / Internal code Intern Code / Code interne Código interno	Dp	De	Gole / Grooves Rillen / Gorges Canales	Forma / Form Forme / Forme Forma	** ØdH8			F	H	Ø S	M	Ø Db	N
					Ø 55	Ø 65	Ø 80						
BK0090155	90	97	1	1	55			25					
BK0090255			2	1	55			44	27				
BK0090355			3	1	55			63	27				
BK0090455			4	1	55			82	27				
BK0090555			5	1	55			101	27				
BK0105155	105	112	1	1	55			25					
BK0105255			2	2	55			44	27		17	65	
BK0105355			3	2	55			63	27		36	65	
BK0105455			4	2	55			82	27		55	65	
BK0105555			5	2	55			101	27		74	65	
BK0112155	112	119	1	1	55			25					
BK0112255			2	2	55			44	27		17	70	
BK0112355			3	2	55			63	27		36	70	
BK0112455			4	2	55			82	27		55	70	
BK0112555			5	2	55			101	27		74	70	
BK01201**	120	127	1	1	55	65		25					
BK01202**			2	2	55	65		44	27		17	78	
BK01203**			3	2	55	65		63	27		36	78	
BK01204**			4	2	55	65		82	27		55	78	
BK01205**			5	2	55	65		101	27		74	78	
BK01251**	125	132	1	1	55	65		25					
BK01252**			2	2	55	65		44	27		17	83	
BK01253**			3	2	55	65		63	27		36	83	
BK01254**			4	2	55	65		82	27		55	83	
BK01255**			5	2	55	65		101	27		74	83	
BK01301**	130	137	1	1	55	65	80	25					
BK01302**			2	2	55	65	80	44	27		17	90	
BK01303**			3	2	55	65	80	63	27		36	90	
BK01304**			4	2	55	65	80	82	27		55	90	
BK01305**			5	2	55	65	80	101	27		74	90	
BK01401**	140	147	1	1	55	65	80	25					
BK01402**			2	2	55	65	80	44	27		17	98	
BK01403**			3	2	55	65	80	63	27		36	98	
BK01404**			4	2	55	65	80	82	27		55	98	
BK01405**			5	2	55	65	80	101	27		74	98	
BK01501**	150	157	1	1	55	65	80	25					
BK01502**			2	2	55	65	80	44	27		17	108	
BK01503**			3	2	55	65	80	63	27		36	108	
BK01504**			4	2	55	65	80	82	27		55	108	
BK01505**			5	2	55	65	80	101	27		74	108	
BK01601**	160	167	1	1	55	65	80	25					
BK01602**			2	2	55	65	80	44	27		17	118	
BK01603**			3	2	55	65	80	63	27		36	118	
BK01604**			4	2	55	65	80	82	27		55	118	
BK01605**			5	2	55	65	80	101	27		74	118	
BK01606**			6	2	55	65	80	120	27		93	118	

** = Diametro del foro della puleggia (sede per calettatore) / Pulley bore diameter (seat for locking device) / Scheibenbohrungsdurchmesser (Sitz für Spannsatz)

Diamètre de l'alésage de la poulie (logement pour moyeu de serrage) / Diámetro del agujero de la polea (sede para casquillo de fijación)

PULEGGE TRAPEZOIDALI PER CALETTATORE V-BELT PULLEYS FOR LOCKING DEVICES

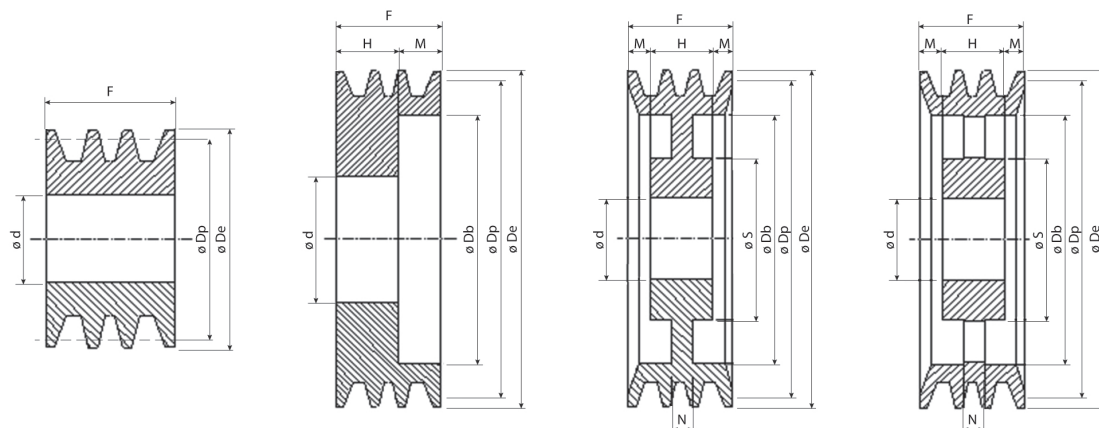

SPB

1

2

3

4

Cod. Interno / Internal code Interner Code / Code interne Código interno	Dp	De	Gole / Grooves Rillen / Gorges Canales	Forma / Form Forme / Forme Forma	** ØdH8			F	H	Ø S	M	Ø Db	N
					Ø 55	Ø 65	Ø 80						
BK01701**	170	177	1	1	55	65	80	25					
BK01702**			2	3	55	65	80	44	27		8,5	128	27
BK01703**			3	3	55	65	80	63	27		18	128	27
BK01704**			4	3	55	65	80	82	27		27,5	128	27
BK01705**			5	3	55	65	80	101	27		37	128	27
BK01801**	180	187	1	1	55	65	80	25					
BK01802**			2	3	55	65	80	44	27		8,5	138	27
BK01803**			3	3	55	65	80	63	27		18	138	27
BK01804**			4	3	55	65	80	82	27		27,5	138	27
BK01805**			5	3	55	65	80	101	27		37	138	27
BK01901**	190	197	1	1	55	65	80	25					
BK01902**			2	3	55	65	80	44	27		8,5	148	27
BK01903**			3	3	55	65	80	63	27		18	148	27
BK01904**			4	3	55	65	80	82	27		27,5	148	27
BK01905**			5	3	55	65	80	101	27		37	148	27
BK02001**	200	207	1	1	55	65	80	25					
BK02002**			2	3	55	65	80	44	27	120	8,5	158	15
BK02003**			3	3	55	65	80	63	27	120	18	158	15
BK02004**			4	3	55	65	80	82	27	120	27,5	158	15
BK02005**			5	3	55	65	80	101	27	120	37	158	15
BK02006**			6	3	55	65	80	120	27	120	46,5	158	18
BK02121**	212	219	1	3	55	65	80	25	25	120		170	15
BK02122**			2	3	55	65	80	44	27	120	8,5	170	15
BK02123**			3	3	55	65	80	63	27	120	18	170	15
BK02124**			4	3		65	80	82	27	120	27,5	170	15
BK02125**			5	3		65	80	101	27	120	37	170	15
BK02251**	225	232	1	3	55	65	80	25	25	120		183	15
BK02252**			2	3	55	65	80	44	27	120	8,5	183	15
BK02253**			3	3	55	65	80	63	27	120	18	183	15
BK02254**			4	3		65	80	82	27	120	27,5	183	15
BK02255**			5	3		65	80	101	27	120	37	183	15
BK02256**			6	3		65	80	120	27	120	46,5	183	18
BK02401**	240	247	1	3	55	65	80	25	25	120		198	16
BK02402**			2	3	55	65	80	44	27	120	8,5	198	16
BK02403**			3	3	55	65	80	63	27	120	18	198	16
BK02404**			4	3		65	80	82	27	120	27,5	198	16
BK02405**			5	3		65	80	101	27	130	37	198	16
BK02501**	250	257	1	3	55	65	80	25	25	120		208	16
BK02502**			2	3	55	65	80	44	27	120	8,5	208	16
BK02503**			3	3	55	65	80	63	27	120	18	208	16
BK02504**			4	3		65	80	82	27	120	27,5	208	16
BK02505**			5	3		65	80	101	27	130	37	208	16
BK02506**			6	3		65	80	120	27	130	46,5	208	18

** = Diametro del foro della puleggia (sede per calettatore) / Pulley bore diameter (seat for locking device) / Scheibenbohrungsdurchmesser (Sitz für Spannsatz)

Diamètre de l'alésage de la poulie (logement pour moyeu de serrage) / Diámetro del agujero de la polea (sede para casquillo de fijación)

PULEGGE TRAPEZOIDALI PER CALETTATORE V-BELT PULLEYS FOR LOCKING DEVICES

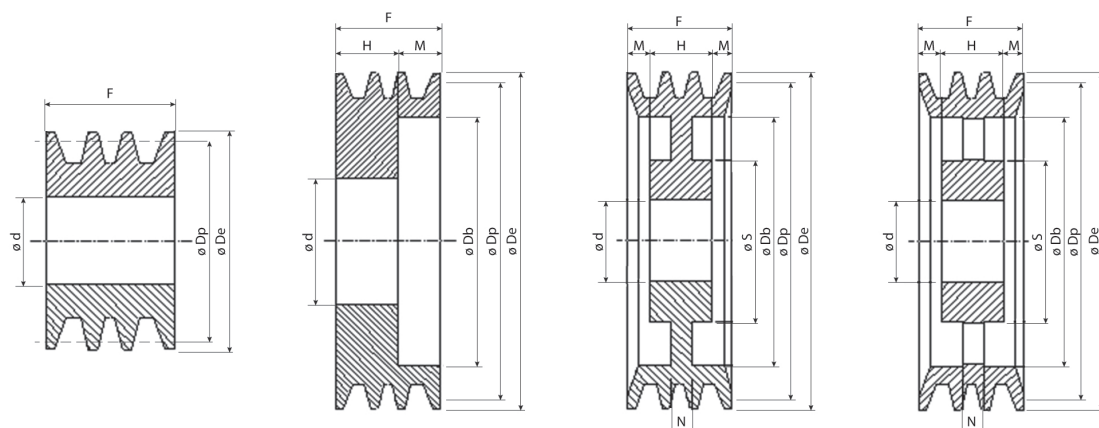

SPB

1

2

3

4

Cod. Interno / Internal code Intern Code / Code interne Código interno	Dp	De	Gole / Grooves Rillen / Gorges Canales	Forma / Form Forme / Forme Forma	** ØdH8			F	H	Ø S	M	Ø Db	N
					Ø 55	Ø 65	Ø 80						
BK02801**	280	287	1	3	55	65	80	25	25	120		238	16
BK02802**			2	3	55	65	80	44	27	120	8,5	238	16
BK02803**			3	3		65	80	63	27	120	18	238	16
BK02804**			4	3		65	80	82	27	120	27,5	238	16
BK02805**			5	3		65	80	101	27	130	37	238	16
BK03001**	300	307	1	4	55	65	80	25	25	130		258	15
BK03002**			2	4	55	65	80	44	27	130	8,5	258	15
BK03003**			3	4		65	80	63	27	130	18	258	18
BK03004**			4	4		65	80	82	27	130	27,5	258	20
BK03005**			5	4		65	80	101	27	130	37	258	22
BK03151**	315	322	1	4	55	65	80	25	25	130		273	15
BK03152**			2	4	55	65	80	44	27	130	8,5	273	15
BK03153**			3	4		65	80	63	27	130	18	273	18
BK03154**			4	4		65	80	82	27	130	27,5	273	20
BK03155**			5	4		65	80	101	27	130	37	273	22
BK03551**	355	362	1	4	55	65	80	25	25	130		308	16
BK03552**			2	4		65	80	44	27	130	8,5	308	18
BK03553**			3	4		65	80	63	27	130	18	308	22
BK03554**			4	4		65	80	82	27	130	27,5	308	22
BK03555**			5	4		65	80	101	27	130	37	308	24
BK03801**	380	387	1	4		65	80	25	25	130		338	20
BK03802**			2	4		65	80	44	27	130	8,5	338	20
BK03803**			3	4		65	80	63	27	130	18	338	22
BK03804**			4	4		65	80	82	27	130	27,5	338	24
BK03805**			5	4		65	80	101	27	130	37	338	24
BK04001**	400	407	1	4		65	80	25	25	130		358	20
BK04002**			2	4		65	80	44	27	130	8,5	358	20
BK04003**			3	4		65	80	63	27	130	18	358	22
BK04004**			4	4		65	80	82	27	130	27,5	358	24
BK04005**			5	4		65	80	101	27	130	37	358	24
BK04251**	425	432	1	4		65	80	25	25	130		383	22
BK04252**			2	4		65	80	44	27	130	8,5	383	22
BK04253**			3	4		65	80	63	27	130	18	383	24
BK04254**			4	4		65	80	82	27	130	27,5	383	24
BK04255**			5	4		65	80	101	27	130	37	383	24
BK04501**	450	457	1	4		65	80	25	25	130		408	20
BK04502**			2	4		65	80	44	27	130	8,5	408	20
BK04503**			3	4		65	80	63	27	130	18	408	24
BK04504**			4	4		65	80	82	27	130	27,5	408	24
BK04505**			5	4		65	80	101	27	130	37	408	24
BK05001**	500	507	1	4		65	80	25	25	130		458	20
BK05002**			2	4		65	80	44	27	130	8,5	458	20
BK05003**			3	4		65	80	63	27	130	18	458	24
BK05004**			4	4		65	80	82	27	130	27,5	458	24
BK05005**			5	4		65	80	101	27	130	37	458	24

** = Diametro del foro della puleggia (sede per calettatore) / Pulley bore diameter (seat for locking device) / Scheibenbohrungsdurchmesser (Sitz für Spannsatz)

Diamètre de l'alésage de la poulie (logement pour moyeu de serrage) / Diámetro del agujero de la polea (sede para casquillo de fijación)

PULEGGE TRAPEZOIDALI PER CALETTATORE

V-BELT PULLEYS FOR LOCKING DEVICES

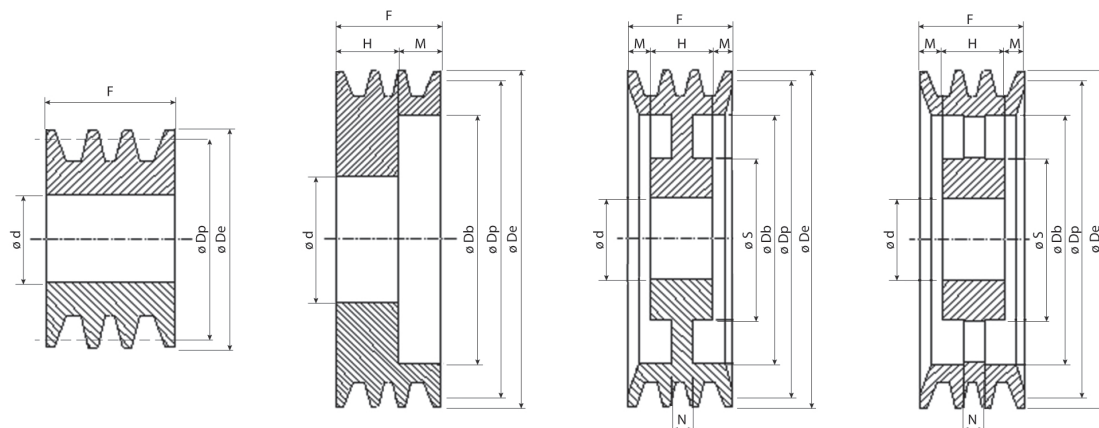

SPC

1

2

3

4

Cod. Interno / Internal code Intern Code / Code interne Código interno	Dp	De	Gole / Grooves Rillen / Gorges Canales	Forma / Form Forme / Forme Forma	** ØdH8			F	H	Ø S	M	Ø Db	N
					Ø 55	Ø 65	Ø 80						
CK01301**	130	139,6	1	2	55	65		34	25		9	75	
CK01302**			2	2	55	65		59,5	27		32,5	75	
CK01303**			3	2	55	65		85	27		58	75	
CK01304**			4	2	55	65		111	27		83,5	75	
CK01305**			5	2	55	65		136	27		109	75	
CK01401**	140	149,6	1	2	55	65		34	25		9	83	
CK01402**			2	2	55	65		59,5	27		32,5	83	
CK01403**			3	2	55	65		85	27		58	83	
CK01404**			4	2	55	65		111	27		83,5	83	
CK01405**			5	2	55	65		136	27		109	83	
CK01501**	150	159,6	1	2	55	65	80	34	25		9	93	
CK01502**			2	2	55	65	80	59,5	27		32,5	93	
CK01503**			3	2	55	65	80	85	27		58	93	
CK01504**			4	2	55	65	80	111	27		83,5	93	
CK01505**			5	2	55	65	80	136	27		109	93	
CK01601**	160	169,6	1	2	55	65	80	34	25		9	103	
CK01602**			2	2	55	65	80	59,5	27		32,5	103	
CK01603**			3	2	55	65	80	85	27		58	103	
CK01604**			4	3	55	65	80	111	27		83,5	103	
CK01605**			5	3	55	65	80	136	27		109	103	
CK01701**	170	179,6	1	2	55	65	80	34	25		9	113	
CK01702**			2	2	55	65	80	59,5	27		32,5	113	
CK01703**			3	2	55	65	80	85	27		58	113	
CK01704**			4	3	55	65	80	111	27		83,5	113	
CK01705**			5	3	55	65	80	136	27		109	113	
CK01801**	180	189,6	1	2	55	65	80	34	25		9	123	
CK01802**			2	2	55	65	80	59,5	27		32,5	123	
CK01803**			3	2	55	65	80	85	27		58	123	
CK01804**			4	3	55	65	80	111	27		83,5	123	
CK01805**			5	3	55	65	80	136	27		109	123	
CK01901**	190	199,6	1	2	55	65	80	34	25		9	133	
CK01902**			2	2	55	65	80	59,5	27		32,5	133	
CK01903**			3	2	55	65	80	85	27		58	133	
CK01904**			4	3	55	65	80	111	27		83,5	133	
CK01905**			5	3	55	65	80	136	27		109	133	
CK02001**	200	209,6	1	2	55	65	80	34	25		9	143	
CK02002**			2	2	55	65	80	59,5	27		32,5	143	
CK02003**			3	2	55	65	80	85	27		58	143	
CK02004**			4	3	55	65	80	111	27		83,5	143	
CK02005**			5	3	55	65	80	136	27		109	143	
CK02251**	225	234,6	1	3		65	80	34	25	120	9	168	18
CK02252**			2	3		65	80	59,5	27	120	32,5	168	18
CK02253**			3	3		65	80	85	27	120	58	168	25
CK02254**			4	3		65	80	111	27	120	83,5	168	25
CK02255**			5	3		65	80	136	27	120	109	168	25

** = Diametro del foro della puleggia (sede per calettatore) / Pulley bore diameter (seat for locking device) / Scheibenbohrungsdurchmesser (Sitz für Spannsatz)

Diamètre de l'alésage de la poulie (logement pour moyeu de serrage) / Diámetro del agujero de la polea (sede para casquillo de fijación)

PULEGGE TRAPEZOIDALI PER CALETTATORE V-BELT PULLEYS FOR LOCKING DEVICES

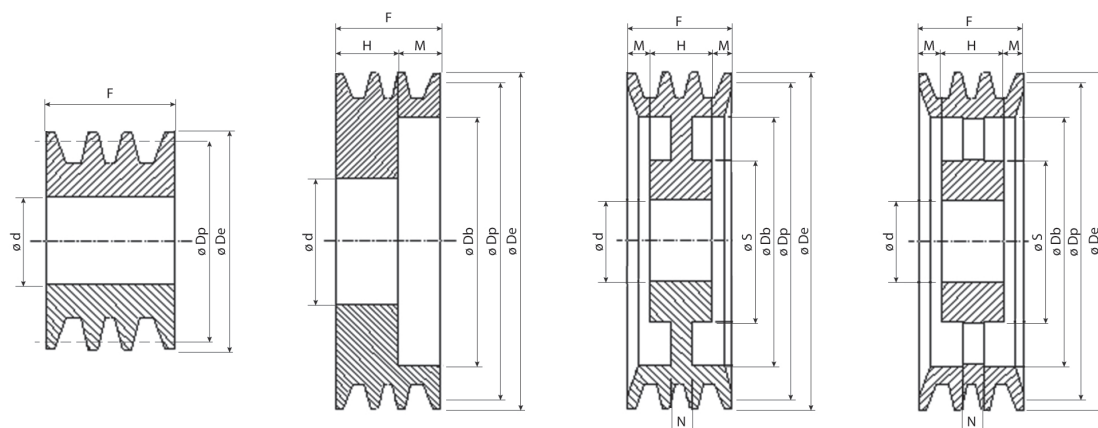

SPC

1

2

3

4

Cod. Interno / Internal code Intern Code / Code interne Código interno	Dp	De	Gole / Grooves Rillen / Gorges Canales	Forma / Form Forme / Forme Forma	** ØdH8			F	H	Ø S	M	Ø Db	N
					Ø 55	Ø 65	Ø 80						
CK02501**	250	259,6	1	3		65	80	34	25	120	4,5	193	18
CK02502**			2	3		65	80	59,5	27	120	16,5	193	18
CK02503**			3	3		65	80	85	27	120	29	193	25
CK02504**			4	3		65	80	111	27	130	42	193	25
CK02505**			5	3		65	80	136	27	130	54,5	193	25
CK02801**	280	289,6	1	3		65	80	34	27	120	3,5	223	18
CK02802**			2	3		65	80	59,5	27	120	16,5	223	18
CK02803**			3	3		65	80	85	27	120	29	223	25
CK02804**			4	3		65	80	136	27	130	42	223	25
CK02805**			5	3		65	80	34	27	130	54,5	223	25
CK03001**	300	309,6	1	3		65	80	59,5	27	120	3,5	243	20
CK03002**			2	3		65	80	85	27	120	16,5	243	20
CK03003**			3	3		65	80	111	27	120	29	243	25
CK03004**			4	3		65	80	136	27	130	42	243	25
CK03005**			5	3		65	80	34	27	130	54,5	243	25
CK03151**	315	324,6	1	4		65	80	59,5	27	130	3,5	258	20
CK03152**			2	4		65	80	85	27	130	16,5	258	20
CK03153**			3	4		65	80	111	27	130	29	258	25
CK03154**			4	4		65	80	136	27	130	42	258	25
CK03155**			5	4		65	80	34	27	130	54,5	258	25
CK03551**	355	364,6	1	4		65	80	59,5	27	130	3,5	298	25
CK03552**			2	4		65	80	85	27	130	16,5	298	25
CK03553**			3	4		65	80	111	27	130	29	298	25
CK03554**			4	4		65	80	136	27	130	42	298	25
CK03555**			5	4		65	80	34	27	130	54,5	298	25
CK03801**	380	389,6	1	4		65	80	59,5	27	130	3,5	323	25
CK03802**			2	4		65	80	85	27	130	16,5	323	25
CK03803**			3	4		65	80	111	27	130	29	323	25
CK03804**			4	4		65	80	136	27	130	42	323	25
CK03805**			5	4		65	80	34	27	130	54,5	323	25
CK04001**	400	409,6	1	4		65	80	59,5	27	130	3,5	343	25
CK04002**			2	4		65	80	85	27	130	16,5	343	25
CK04003**			3	4		65	80	111	27	130	29	343	25
CK04004**			4	4		65	80	136	27	130	42	343	25
CK04005**			5	4		65	80	34	27	130	54,5	343	25
CK04251**	425	434,6	1	4		65	80	59,5	27	130	3,5	368	25
CK04252**			2	4		65	80	85	27	130	16,5	368	25
CK04253**			3	4		65	80	111	27	130	29	368	25
CK04254**			4	4		65	80	136	27	130	42	368	25
CK04255**			5	4		65	80	34	27	130	54,5	368	25
CK04501**	450	459,6	1	4		65	80	59,5	27	130	3,5	393	25
CK04502**			2	4		65	80	85	27	130	16,5	393	25
CK04503**			3	4		65	80	111	27	130	29	393	25
CK04504**			4	4		65	80	136	27	130	42	393	25
CK04505**			5	4		65	80	34	27	130	54,5	393	25
CK05001**	500	509,6	1	4		65	80	59,5	27	130	3,5	443	25
CK05002**			2	4		65	80	85	27	130	16,5	443	25
CK05003**			3	4		65	80	111	27	130	29	443	25
CK05004**			4	4		65	80	136	27	130	42	443	25
CK05005**			5	4		65	80	34	27	130	54,5	443	25

** = Diametro del foro della puleggia (sede per calettatore) / Pulley bore diameter (seat for locking device) / Scheibenbohrungsdurchmesser (Sitz für Spannsatz)

Diamètre de l'alésage de la poulie (logement pour moyeu de serrage) / Diámetro del agujero de la polea (sede para casquillo de fijación)

PULEGGE VARIABILI
ADJUSTABLE PULLEYS



PULEGGE VARIABILI ADJUSTABLE PULLEYS

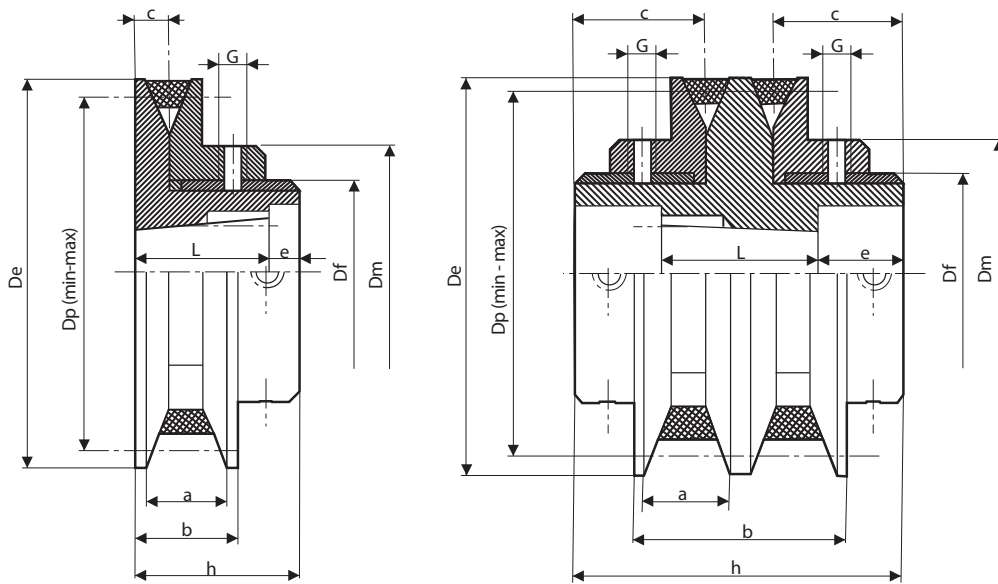

Ghisa
EN-GJL-250 UNI EN
1561

Cast iron
EN-GJL-250 UNI EN
1561

Grauguss
EN-GJL-250 UNI EN
1561

Fonte
EN-GJL-250 UNI EN
1561

Hierro fundido
EN-GJL-250 UNI EN
1561

Dimensioni / Dimensions / Abmessungen / Encombrements / Dimensiones

Descrizione Description Beschreibung Description Descripción	Bussola Bush Buchse Moyeu Casquillo	Foro Bore Bohrung Alesage Agujero	De	Dm	Df	Dp		a	a	b	b	c	e	G	h	L	Kg
						min	max										
VAR* 84 Z1	1108	28	84	65	50	62	80	14,5	10	19,5	15	7,5	-	6	28	28,0	0,50
VAR 95 Z1	1108	28	95	75	60	73	91	14,5	10	20,5	16	8,0	8,0	6	30	22,0	0,78
VAR 100 Z1	1108	28	100	75	60	78	96	14,5	10	20,5	16	8,0	8,0	6	30	22,0	0,85
VAR 108 Z1	1210	30	108	90	72	90	104	14,5	10	20,5	16	8,0	10,0	8	35	25,0	1,13
VAR* 108 A1	1210	30	108	80	62	76	102	19,5	13	26,5	19	9,5	12,0	8	39	27,0	1,12
VAR 120 A1	1210	30	120	91	72	88	114	19,5	13	26,5	20	10,0	10,0	8	36	26,0	1,42
VAR 120 A2	1215	30	120	91	72	88	114	19,5	13	47,1	34	26,0	12,0	8	66	40,5	2,46
VAR 129 A1	1210	30	129	91	72	97	123	19,5	13	26,5	20	10,0	10,2	8	36	26,0	1,67
VAR 129 A2	1215	30	129	91	72	97	123	19,5	13	47,1	34	26,0	12,0	8	66	40,0	2,83
VAR 139 A1	1610	40	139	103	85	109	133	18,9	13	25,9	20	10,0	11,0	8	37	26,0	1,96
VAR 139 A2	1615	40	139	103	85	109	133	18,9	13	46,8	35	26,0	14,5	8	69	38,5	3,37
VAR 146 A1	1610	40	146	103	85	116	140	18,9	13	25,9	20	10,0	11,0	8	37	26,0	2,17
VAR 146 A2	1615	40	146	103	85	116	140	18,9	13	46,8	35	27,0	14,5	8	69	38,5	3,77
VAR 156 A1	1610	40	156	103	85	126	150	18,9	13	25,9	20	10,0	11,0	8	37	26,0	2,43
VAR 156 A2	1615	40	156	103	85	126	150	18,9	13	46,8	35	27,0	14,5	8	69	38,5	4,25
VAR 164 A1	1610	40	164	103	85	134	158	18,9	13	25,9	20	10,0	8,0	8	37	29,0	2,76
VAR 164 A2	1615	40	164	103	85	134	158	18,9	13	46,8	35	27,0	15,5	8	69	37,5	4,74
VAR 177 A1	2012	50	177	135	110	149	171	18,2	13	25,2	20	10,0	8,0	8	40	32,0	3,76
VAR 177 A2	2012	50	177	135	110	149	171	18,2	13	45,5	35	27,5	24,0	8	90	37,0	6,80
VAR 187 A1	2012	50	187	135	110	159	181	18,2	13	25,2	20	10,0	8,0	8	40	32,0	4,14
VAR 187 A2	2012	50	187	135	110	159	181	18,2	13	45,5	35	37,5	24,0	8	90	37,0	7,50
VAR 178 B1	2012	50	178	135	110	139	171	21,5	16	28,5	23	10,0	8,0	8	40	32,0	3,73
VAR 178 B2	2012	50	178	135	110	139	171	22,5	16	54,5	42	37,5	24,0	8	90	37,0	6,75
VAR 187 B1	2012	50	187	135	110	148	180	21,5	16	28,5	23	10,0	8,0	8	40	32,0	4,70
VAR 187 B2	2012	50	187	135	110	148	180	22,5	16	54,5	42	37,5	24,0	8	90	37,0	7,35

* Montaggio bussola
contrario allo schema

* Bush assembly opposite to
the scheme

* Entgegengesetzte
Buchse montage

* Montage moyeu contraire
au schema

* Montaje buje al revés del
croquis

PULEGGE VARIABILI ADJUSTABLE PULLEYS



**Potenza nominale trasmessa / Nominal power / Nominalleistung / Puissance nominale / Potencia nominal
kW**

Descrizione / Description Beschreibung Description Descripción	1450 rpm		1600 rpm		2000 rpm		2500 rpm		2800 rpm	
	n max	n min	n max	n min	n max	n min	n max	n min	n max	n min
VAR* 84 Z1	1,60	0,80	1,80	1,00	2,00	1,20	2,30	1,40	2,60	1,50
VAR 95 Z1	2,10	1,30	2,42	1,56	2,74	1,80	3,15	2,10	3,69	2,35
VAR 100 Z1	2,30	1,50	2,50	1,80	2,90	2,00	3,20	2,30	3,80	2,60
VAR 108 Z1	2,70	2,00	3,10	2,30	3,10	2,30	3,90	2,90	4,60	3,40
VAR* 108 A1	3,20	1,50	3,79	1,70	4,30	1,96	4,89	2,22	5,64	2,55
VAR 120 A1	3,70	1,80	3,79	2,07	4,34	2,25	4,80	2,52	5,45	2,79
VAR 120 A2	7,40	3,60	7,49	4,14	8,69	4,50	9,61	5,04	10,90	5,58
VAR 129 A1	4,20	2,50	5,20	2,87	6,10	3,70	6,60	4,26	7,50	4,82
VAR 129 A2	8,40	5,00	10,40	5,74	12,20	7,41	13,20	8,52	15,00	9,63
VAR 139 A1	5,00	3,40	5,70	3,90	5,70	3,90	7,30	5,10	8,30	5,70
VAR 139 A2	10,00	6,80	11,40	7,80	11,40	7,80	14,60	10,20	16,60	11,40
VAR 146 A1	5,50	3,80	6,40	4,40	6,40	4,40	8,10	5,60	9,30	6,60
VAR 146 A2	11,00	7,60	12,80	8,80	12,80	8,80	16,20	11,20	18,60	13,20
VAR 156 A1	6,20	4,50	7,20	5,10	7,20	5,10	9,10	6,50	10,40	7,50
VAR 156 A2	12,40	9,00	14,40	10,20	14,40	10,20	18,20	13,00	20,80	15,00
VAR 164 A1	6,70	5,10	7,80	5,70	7,80	5,70	10,00	7,30	11,20	8,30
VAR 164 A2	13,40	10,20	15,60	11,40	15,60	11,40	20,00	14,60	22,40	16,60
VAR 177 A1	7,50	6,10	8,70	7,10	8,70	7,10	11,10	8,00	12,50	10,30
VAR 177 A2	15,00	12,20	17,40	14,20	17,40	14,20	22,60	18,00	25,00	20,60
VAR 187 A1	8,20	6,80	9,50	7,80	9,50	7,80	12,00	10,10	13,60	11,30
VAR 187 A2	16,40	13,60	19,00	15,60	19,00	15,60	24,00	20,20	27,20	22,60
VAR 178 B1	9,30	5,90	10,57	6,32	11,94	7,37	12,66	8,46	13,89	9,24
VAR 178 B2	18,60	11,80	21,14	12,64	25,37	14,63	27,84	15,88	30,53	17,34
VAR 187 B1	10,30	6,80	11,44	7,51	13,73	8,22	14,56	9,44	15,60	10,15
VAR 187 B2	20,60	13,60	22,89	15,02	27,47	16,44	29,13	18,88	31,21	20,30

SLITTE TENDICINGHIA PER MOTORI ELETTRICI MOTOR SLIDES FOR ELECTRIC MOTORS

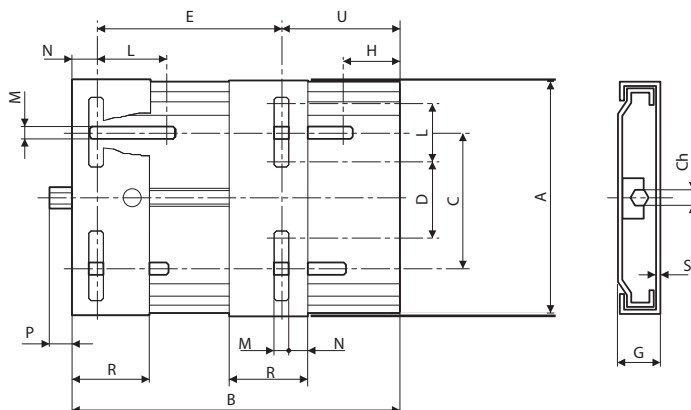
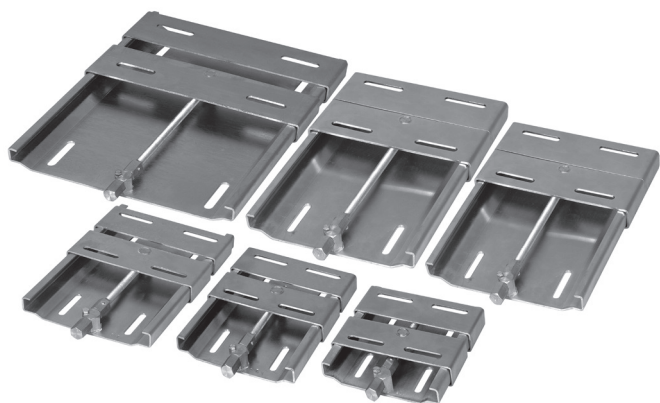

Le slitte tendicinghia per motori elettrici permettono di regolare il tensionamento o lo smontaggio delle cinghie senza rimozione del motore elettrico.

Questa caratteristica, e le semplici operazioni di smontaggio, consentono una rapida risoluzione del problema di tensionamento delle cinghie nelle trasmissioni di potenza.

La vite che comanda il movimento della slitta si regola infatti con una comune chiave.

La lamiera in acciaio zincato utilizzato per la fabbricazione delle slitte, protegge dalla corrosione e dall'ossidazione.

The motor slides for electric motors allow the tension adjustment or disassembly of the belt without removing the electric motor.

This feature, and the easy disassembly, quickly solves the problem of the belt tension in the power transmission.

The screw that controls the movement of the motor slide is in fact adjusted by a common key.

The zinc plated steel, used to produce the motor slides, protects against oxidation and corrosion.

Die Schlitten für Elektromotoren ermöglichen die Spannungseinstellung und die Abmontierung des Riemens ohne dass der Elektromotor ausgebaut werden muss.

Diese Eigenschaft, und die einfache Demontage, ermöglichen eine schnelle Einstellung der Riemenspannung bei Leistungsantrieben.

Die Schraube zum Steuern der Schlittenbewegung wird nämlich durch einen gewöhnlichen Schlüssel eingestellt.

Das verzinkte Stahlblech, das zum Bauen der Schlitten benutzt wird, ist korrosions- und oxydationsfest.

Les glissières de tension permettent de régler le tensionnement ou de démonter les courroies sans déplacer le moteur électrique.

Cette caractéristique, ainsi que la facilité de démontage des glissières, permettent de résoudre très rapidement le problème de tensionnement des courroies dans les transmissions de puissance.

En effet la vis qui entraîne le mouvement de la glissière se règle à l'aide d'une clé ordinaire.

La tôle en acier zingué utilisée pour la fabrication des glissières est résistante à la corrosion et l'oxydation.

Las bases tensoras para motores eléctricos, permiten el tensado y destensado manual de las correas sin quitar el motor eléctrico.

Esta característica y la fácil operación de desmontar el motor, hacen una rápida solución del problema de tensado de las correas para poder transmitir la potencia adecuada.

El desplazamiento se regula con un tornillo estándar de fácil manejo.

Estas bases tensoras son fabricadas en acero zincado, esto nos permite mayor dureza contra la oxidación y la corrosión.

Dimensioni / Dimensions / Abmessungen / Encombrements / Dimensiones

Descrizione Description Beschreibung Description Descripción	A	B	C	D	E	G	H	L	M	N	P	R	S	U	Ch	Grandezza motori Electric motor size Motorenabmessung Dimension moteur Tamaño motores electricos
SLITTE TENDIT. TYPE 210	195	210	98	43	100	34	25	50	10,5	20	38	70	3	90	19	63 / 80
SLITTE TENDIT. TYPE 270	195	270	98	43	100	33	25	50	10,5	20	38	70	3	150	19	63 / 112
SLITTE TENDIT. TYPE 307	213	307	108	65	100	35	30	50	10,5	20	42	70	3	175	19	90 / 112
SLITTE TENDIT. TYPE 340	290	340	165	90	135	40	30	62	12,5	27	26	95	4	180	22	90 / 132
SLITTE TENDIT. TYPE 430	290	430	165	90	132	40	29	62	12,5	27	30	95	4	271	22	90 / 160
SLITTE TENDIT. TYPE 490	410	490	284	193	114	40	30	60	15,0	40	24	95	4	336	22	160 / 180

**GIUNTI DENTATI SG
TOOTHED COUPLINGS SG**



GIUNTI DENTATI SG CON MANICOTTO IN POLIAMMIDE TOOTHED COUPLINGS SG WITH PA SLEEVE

Giunti flessibili dentati a doppia curvatura

Presentazione

I giunti flessibili a denti della serie SG, sono giunti commerciali per impiego generico, che presentano tuttavia un elevato standard qualitativo ed offrono caratteristiche tecniche e prestazioni tipiche dei giunti industriali.

Il settore d'impiego specifico, è quello delle trasmissioni di potenza per il collegamento flessibile di organi rotanti, con possibilità di compensare disallineamenti radiali ed angolari e di assorbire scorrimenti in direzione assiale.

Le prestazioni sono quelle tipiche di questa categoria di giunti, rese più severe e meglio adatte alle esigenze della pratica industriale, dai criteri progettuali adottati e della cura con la quale vengono lavorati e sistematicamente controllati.

Costruzione

Costruttivamente i giunti flessibili a denti sono costituiti da due mozzetti simmetrici in acciaio e da un manicotto in resina sintetica che assicura l'accoppiamento e la trasmissione di potenza tra i due mozzetti.

I due mozzetti in acciaio a basso tenore di carbonio e con trattamento superficiale anticorrosione, sono dotati ciascuno di una corona dentata.

Il manicotto cavo a dentatura interna ottenuto da stampaggio ad iniezione, è costituito da una tecnopolimero semicristallino ad alto peso molecolare, garantito da certificazione all'origine, condizionato termicamente e caricato con un lubrificante solido che contribuisce ad esaltare le caratteristiche di autolubrificazione tipiche del polimero.

La dentatura dei due mozzetti a doppia curvatura progressiva, ottenuta su macchina utensile a CN, assicura al giunto prestazioni ottimali, consentendo la compensazione ANCHE SOTTO CARICO di disassamenti angolari e radiali di natura dinamica. A parità di un momento torcente trasmesso, la geometria specifica del dente, riduce considerevolmente la pressione superficiale aumentando la capacità di trasmissione del carico da parte del giunto e la sua resistenza alla fatica.

La relativa insensibilità all'umidità atmosferica del polimero e la sua capacità di sopportare temperature tra -20 e +120 gradi Centigradi con punte di breve durata fino a +150 gradi, rendono il giunto idoneo a sopportare condizioni di impiego gravose anche in ambiente ostile.

Flexible gear coupling with double curving

Introduction

Flexible gear couplings SG Series are general purpose commercial couplings, featuring high quality standards as well as technical characteristics and performances which are peculiar of industrial couplings.

Power transmissions are the specific field of application for flexible couplings, that provide flexible connection of rotating elements.

In addition to transmitting torque, gear couplings are able to compensate for radial and angular misalignment as well as minimize axial sliding.

Thanks to a superior design and extremely accurate processing and quality control, SG couplings ensure enhanced performances with respect to the other couplings of their category, which make them suitable to any industrial application.

Construction

From a constructive point of view flexible gear couplings are made of two symmetric steel hubs and a synthetic resin sleeve ensuring connection and power transmission between the two hubs.

Each of the two hubs in low carbon steel with anticorrosive surface treatment is fitted with a toothed rim.

The hollow sleeve with internal toothing made by injection moulding is made of semicrystalline technopolymer with high molecular weight.

This material, guaranteed by an original certificate, is thermally conditioned and filled with a solid lubricant heightening the self-lubricating properties of this polymer. The double incrementally curved toothing of the two hubs, obtained on NC machines, ensures the achievement of optimal performances, enabling compensation of angular and radial misalignments of dynamic type even under load.

In case of equal transmitted torque, the specific tooth geometry minimizes considerably the surface pressure, while increasing the coupling's endurance as well as its load transmission capacity.

The relative resistance of the polymer to outside humidity and its capacity to endure temperatures between -20°C and +120°C, with short peaks up to +150°C, make the coupling ideal to suffer heavy working conditions even in adverse environments.

Flexible kupplungen mit doppel bogenverzahnung

Allgemeine Beschreibung

Die Bogenzahn-Kupplungen der Baureihe SG sind handelsübliche Kupplungen für allgemeine Anwendungen mit den typischen technischen Merkmalen und Leistungen der industriellen Kupplungen, die sich allerdings durch einen hohen Qualitätsniveau hervorheben. Der spezielle Anwendungsbereich für Bogenzahn-Kupplungen der Baureihe SG im Rahmen der Antriebstechnik ist die flexible Verbindung zwischen sich drehenden Teilen, sowie der Ausgleich von Radial- und Winkelverlagerungen und die Aufnahme von Axialgleitungen.

Die üblichen Leistungen dieser Kupplungsart wurden durch qualitativ hochwertige Planung, sorgfältige Bearbeitungen und eine einwandfreie Endkontrolle verstärkt, daher eignen sich SG-Kupplungen besser für anspruchsvolle Bedürfnisse in der Industriepraxis.

Bauweise

Bogenzahn-Kupplungen bestehen aus zwei symmetrischen Naben mit Außenverzahnung, die aus einem Stahl mit niedrigem Kohlenstoffgehalt und korrosionsfester Oberflächenbehandlung gefertigt sind.

Die zwei Naben werden durch eine Kunstharz-Außenhülse, die zur Kraftübertragung eine entsprechende Innenverzahnung aufweist, miteinander verbunden.

Die einspritzgegossene Hülse besteht aus einem wärmebehandelten halbkristallinen Technopolymer mit hohem Molekulargewicht, garantiert von einer Originalbescheinigung.

Dieser Werkstoff wird mit einem Schmierstoff gefüllt, das die natürliche Schmierfähigkeit der Polymere aufbessert.

Die doppelte progressive Verzahnung der zwei Naben, von numerisch gesteuerten Maschinen ausgeführt, sichert eine optimale Funktion und den Ausgleich dynamischer Kräfte (Winkel- und Radialverlagerungen) auch unter Last und bei laufendem Betrieb.

Bei gleichem übertragenem Drehmoment bewirkt die Geometrie der Zähne eine erhebliche Reduzierung der Flächenpressung.

Damit ist die Kupplung in der Lage, höhere Kräfte mit höherer Ermüdungsfähigkeit zu übertragen.

Accouplements élastiques à denture à double courbure

Résentation

Les accouplements flexibles série SG sont des accouplements commerciaux pour emploi général, qui toutefois présentent un haut niveau de qualité et des caractéristiques techniques et performances propres aux accouplements industriels.

Leur domaine d'emploi spécifique est celui des transmissions de puissance pour la liaison flexible entre deux arbres tournants, avec la possibilité de compenser les désalignements radiaux et angulaire ainsi que d'absorber les glissements en direction axiale.

Leur performances sont celles typiques de cette catégorie d'accouplements, mais rendues plus sévères et donc plus appropriées aux exigences de l'usage industriel grâce aux critères projectuels adoptés et au grand soin avec lequel ils sont usinés et systématiquement contrôlés.

Construction

Au point de vue constructif, les accouplements flexibles à denture sont constitués par deux moyeux symétriques en acier et un manchon en résine synthétique qui assure le couplage et la transmission de puissance entre les deux moyeux.

Chacun des moyeux, réalisés en acier à faible teneur de carbone et avec traitement de surface anti-corrosion, est pourvu d'une bague dentée sur l'un des deux bords.

Le manchon à denture intérieure obtenu à travers un moulage à injection, est constitué d'un technopolymère demi-cristallin de haut poids moléculaire, garanti par un certificat original, conditionné thermiquement et chargé avec un lubrifiant solide qui aide à exalter les caractéristiques autolubrifiantes du polymère. La denture des deux moyeux à double courbure progressive, obtenue sur machines-outils CNC, assure à l'accouplement des performances optimales, permettant la compensation, même sous charge, de désalignements angulaires et radiales de nature dynamique.

À égalité de moment de torsion transmis, la géométrie spécifique de la dent réduit considérablement la pression superficielle tout en accroissant la capacité de l'accouplement de transmettre la charge ainsi que de résister à la fatigue.

Acoplamiento dentado flexible de doble curvatura

Presentación

Los acoplamiento dentado flexibles de la serie SG son acoplamiento comerciales para uso general, que sin embargo se caracterizan por su elevada calidad y por ofrecer características técnicas y prestaciones típicas de los acoplamiento industriales.

El sector de empleo específico es el de las transmisiones de potencia para la conexión flexible entre órganos giratorios y permiten tanto compensar desalineaciones radiales y angulares, como absorber deslizamientos en dirección axial.

Presentan las prestaciones típicas de esta categoría de acoplamiento y, gracias a los criterios de diseño, al especial cuidado en la fabricación y a los controles sistemáticos, son aún más fiables y se adaptan mejor al uso industrial.

Construcción

Los acoplamiento dentado flexibles están formados por dos cubos de acero simétricos y un manguito de resina sintética que asegura el acoplamiento y la transmisión de potencia entre los dos cubos. Cada uno de los dos cubos de acero bajos en carbono y con tratamiento superficial anticorrosión tiene una corona dentada.

El manguito hueco dentado interiormente, obtenido a través de moldeo por inyección, está formado por un tecnopolimero semicristalino de elevado peso molecular. Este material, garantizado por el certificado de origen, está condicionado térmicamente y relleno de lubricante sólido que contribuye a exaltar las características de autolubrificación típicas del polímero. El dentado de los dos cubos de doble curvatura progresiva se obtiene con la máquina herramienta de control numérico y garantiza óptimas prestaciones del acoplamiento, permitiendo la compensación de desalineaciones dinámicas tanto angulares como radiales INCLUSO BAJO CARGA.

Con el mismo par de torsión la geometría específica del diente reduce notablemente la presión sobre la superficie, aumentando la capacidad de transmisión de la carga por parte del acoplamiento y su resistencia a la fatiga.

GIUNTI DENTATI SG CON MANICOTTO IN POLIAMMIDE TOOTHED COUPLINGS SG WITH PA SLEEVE

Caratteristiche

In pratica i giunti offrono le sottospicificate prestazioni:

- Ingombro, peso e momento d'inerzia ridotti.
- Comportamento omocinetico alla velocità.
- Silenziosità di marcia e capacità di assorbire elasticamente urti e vibrazioni.
- Resistenza ai più comuni aggressivi chimici ed al calore moderato, max. temp. 80°.
- Sono autolubrificanti, elettricamente isolanti e non richiedono manutenzione.
- Risultano di costo contenuto, di facile montaggio e si prestano ad una molteplicità di impieghi anche gravosi.

Features and benefits

- Compact design, reduced weight and moment of inertia
- Constant-velocity movement
- Noiseless running, elastic damping of shocks and vibrations
- Resistance to the most common chemicals and to moderate heat, max 80°C
- Self-lubricating, non-conductive and maintenance-free
- Reasonable price, easy to mount, suitable for multiple duties, even the heaviest ones.

Die relativ geringe Empfindlichkeit des Polymers auf Luftfeuchtigkeit und seine Eigenschaft, Temperaturen zwischen -20°C und +120°C, mit kurzzeitigen Temperaturspitzen bis +150°C, auszuhalten, machen die Kupplung fähig zu größten Belastungen, auch unter ungünstigen Arbeitsbedingungen.

Merkmale und Nutzen

SG Bogenzahn-Kupplungen bieten die folgenden Vorteile:

- Kompakte Bauweise - Kleines Gewicht - Reduziertes Trägheitsmoment
- Gleichlaufverhalten
- Geräuscharmer Betrieb - Elastische Dämpfungsfähigkeit bei Stößen und Vibrationen
- Widerstand gegen die üblichsten Chemikalien und begrenzte Wärme
- Automatische Schmierung - Elektrisches Isoliervermögen
- Wartungsfreiheit
- Günstiger Anschaffungspreis
- Leichte Montage - Vielfalt der Anwendung, auch unter schweren Bedingungen.

La relativa insensibilità à l'humidité atmosphérique du polymère et son endurance à températures entre -20° et +120°C, avec de brefs pics jusqu'à +150°C, rendent l'accouplement apte à endurer des conditions sévères de fonctionnement même dans un environnement hostile

Caracteristique et avantages

- Encombrement et poids réduits - Faible inertie
- Comportement homocinétique à la vitesse
- Marche silencieuse - Capacité d'absorber élastiquement les chocs et les vibrations
- Résistance aux produits chimiques plus communs et à la chaleur modérée
- Autolubrifiants - Électriquement isolants - Sans entretien
- De prix avantageux, faciles à monter, ils se prêtent à plusieurs utilisations, même les plus lourdes.

La relativa insensibilidad a la humedad atmosférica del polímero y su capacidad de resistir a oscilaciones de temperatura entre -20°C y +120°C, con picos de breve duración de hasta +150°C, hacen que el acoplamiento resulte adecuado para resistir a condiciones muy difíciles y también a un ambiente hostil.

Características

Los acoplamientos ofrecen las siguientes ventajas concretas:

- Dimensiones, peso y momento de inercia reducidos.
- Comportamiento homocinético con respecto a la velocidad.
- Silenciosidad en marcha y capacidad de absorber elásticamente choques y vibraciones.
- Resistencia a los agresivos químicos más usuales y al calor moderado (temperatura máxima 80°C).
- Autolubrificantes, eléctricamente aislantes y no necesitan mantenimiento.
- Tienen un coste reducido, son fáciles de montar y pueden utilizarse para diferentes empleos, incluso pesados.

Disassamenti

Disalignements

Auslagerungen

Desalignements

Desalineaciones

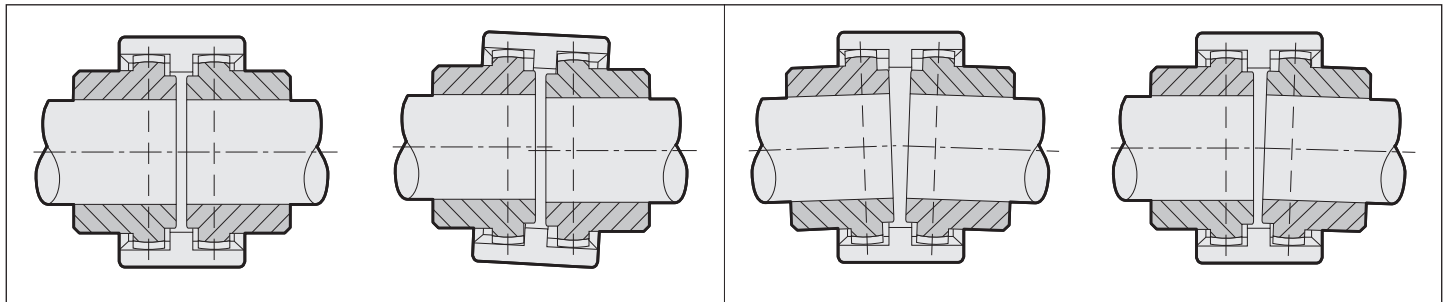

Alberi allineati

Aligned shafts

Genauere Wellenausrichtung

Arbres alignés

Ejes alineados

Alberi spostati radialmente

Radial misalignment

Radialverlagerung

Désalignement radial

Desalineación radial

Alberi spostati angolarmente

Angular misalignment

Winkelverlagerung

Désalignement angulaire

Desalineación angular

Alberi spostati radialmente e angolarmente

Radial and angular misalignment

Radial- und Winkelverlagerung

Désalignement radial et angulaire

Desalineación radial y angular

GIUNTI DENTATI SG CON MANICOTTO IN POLIAMMIDE TOOTHED COUPLINGS SG WITH PA SLEEVE

Scelta del giunto

Scelta in base alla coppia: il giunto deve essere scelto in modo che la coppia max del motore non superi il momento torcente di punta ammissibile del giunto.

Coupling selection

Torque-based selection: the coupling must be chosen basing on the max. motor torque, which should never exceed the coupling's permissible peak torque.

Kupplungsauswahl

Auswahl nach Drehmoment: die Kupplung muß so ausgewählt werden, daß das max. Motordrehmoment das max. zulässige Spitzendrehmoment der Kupplung nicht überschreitet.

Choix de l'accouplement

Choix selon le couple: l'accouplement doit être choisi de façon que le couple max. du moteur ne dépasse pas le couple de crête admissible de l'accouplement.

Elección del acoplamiento

La elección depende del par: se tiene que elegir el acoplamiento de manera que el par máximo del motor no supere el par máximo de torsión permitido por el acoplamiento.

Dati tecnici

Technical data

Technische daten

Données techniques

Datos técnicos

Giunto Tipo Type of coupling Kupplungsart Type d'accouplement Tipo de acoplamiento	Fattore di potenza r.p.m. Power factor rpm Leistungsfaktor Upm Facteur de puissance tpm Factor de potencia r.p.m.		Coppia Torque Drehmoment Couple PAR		Potenza trasmessa in kw a giri/minuto Transmitted power in kw to rpm Übertragene leistung in kw nach upm Puissance transmise en kw a tpm Potencia transmitida en kw a r.p.m.								Giri/1' Max. Rpm/1' max Tours/1' Max. Upm/1' max Revoluciones/1	(1) Massa Mass Masse Masa Kg	(1) J Kg cm ²	Disassamento Massimo per Ogni mozzo Max. Disalignment per hub Max. Verlagerung für jede nabe Désalignement max. Pour chaque moyeu Desalineación máx. Por cada cubo	Spostamento assiale Axial misalignment Axialverlagerung Désalignement axial Desalineación axial	
	norm.	max.	norm.	max.	750		1000		1500		3000							
					norm.	max.	norm.	max.	norm.	max.	norm.	max.						
SG-14	0.0011	0.0023	11,5	23,0	0,8	1,5	1,1	2,0	1,6	3,0	3,3	6,0	14000	0,166	0,27	± 2°	0,7	± 1
SG-19	0.0019	0.0037	18,5	36,5	1,3	2,7	1,8	3,7	2,7	5,5	5,4	11,1	12000	0,276	0,64	± 2°	0,8	± 1
SG-24	0.0023	0.0047	23,0	46,0	1,7	3,5	2,3	4,7	3,4	7,0	6,9	14,1	10000	0,312	0,92	± 2°	0,8	± 1
SG-28	0.0053	0.0106	51,5	103,5	3,9	7,9	5,2	10,6	7,8	15,9	15,6	31,8	8000	0,779	3,45	± 2°	1,0	± 1
SG-32	0.0071	0.0142	69,0	138,0	5,2	10,5	7,0	14,1	10,5	21,1	21,0	42,3	7100	0,918	5,03	± 2°	1,0	± 1
SG-38	0.0090	0.0181	88,0	176,0	6,7	13,5	9,0	18,0	13,5	27,0	27,0	54,0	6300	1,278	9,59	± 2°	0,9	± 1
SG-42	0.0113	0.0226	110,0	220,0	8,4	16,8	11,2	22,5	16,8	33,7	33,6	67,5	6000	1,473	13,06	± 2°	0,9	± 1
SG-48	0.0158	0.0317	154,0	308,0	11,8	23,6	15,8	31,6	23,7	47,4	47,4	94,8	5600	1,777	18,15	± 2°	0,9	± 1
SG-55	0.0290	0.0580	285,0	570,0	21,7	43,5	29,0	58,0	43,5	87,0	87,0	174,0	4800	3,380	49,44	± 2°	1,2	± 1
SG-65	0.0432	0.0865	420,0	840,0	32,1	64,3	42,9	85,8	64,3	128,7	128,7	257,4	4000	4,988	106,34	± 2°	1,3	± 1

- (1) Riferimento al giunto normale completo di foro massimo senza cava.
(2) Per mozzo

- (1) Refers to the standard coupling complete with max. bore and no keyway.
(2) Per hub

- (1) Bezieht sich auf die Standardkupplung versehen mit max. Bohrung ohne Nut.
(2) Für jede Nabe

- (1) Se réfère à l'accouplement standard pourvu d'alésage max. sans rainure.
(2) Pour chaque moyeu

- (1) Relativo al acoplamiento estándar con agujero máximo sin ranura.
(2) Por cada cubo

Norme per il montaggio

- Fissare i due semi-giunti agli alberi, facendo attenzione che le facciate interne siano a filo con le estremità degli alberi.
- Infilare il manicotto sui due semigiunti regolando la distanza degli stessi (quota "S") allineando contemporaneamente i due alberi.
- Fissare in posizione i due elementi da accoppiare.
- Prima di far ruotare il giunto verificare che il manicotto sia libero di spostarsi assialmente.

Mounting instructions

- Fasten the two half-couplings to their respective shafts, making sure that their inner sides are flush with the shaft ends.
- Drive the sleeve onto the two half-couplings while adjusting the distance between them („S" dimension) and aligning the two shafts.
- Bring the two elements you wish to connect to their respective positions.
- Before you rotate the coupling, make sure that the sleeve is free to travel axially.

Montageanleitungen

- Die zwei Kupplungshälfte an die Wellen befestigen, unter Berücksichtigung, daß die inneren Seiten mit den Wellenenden fluchtend angeordnet sind.
- Die zwei Kupplungshälfte in die Hülse stecken, und dabei den Abstand zwischen den (Abmessung „S") regulieren und gleichzeitig die zwei Wellen aneinander fluchten.
- Die zu verbindenden Elemente in Position bringen.
- Bevor Sie die Kupplung kreisen lassen, vergewissern Sie sich, daß sich die Hülse axial frei bewegen kann.

Instructions de montage

- Fixer les deux demi-accouplements sur les arbres, en s'assurant que les surfaces intérieures soient en droite ligne avec les bouts des arbres.
- Introduire les deux demi-accouplements dans le manchon et régler la distance entre eux (dimension S), en alignant en même temps les deux arbres.
- Fixer en position les éléments à accoupler.
- Avant de faire tourner l'accouplement, s'assurer que le manchon soit libre de se déplacer axialement.

Instrucciones para el montaje

- Fijar los dos cubos sobre los ejes, controlando que las superficies interiores se encuentren a ras de los extremos de los ejes.
- Introducir los dos cubos dentro del manguito regulando la distancia entre los mismos (cota "G"), alineando simultáneamente los dos ejes.
- Fijar en posición los elementos a acoplar.
- Antes de efectuar la rotación del acoplamiento, verificar que el manguito pueda desplazarse libremente en sentido axial.

GIUNTI DENTATI SG CON MANICOTTO IN POLIAMMIDE TOOTHED COUPLINGS SG WITH PA SLEEVE

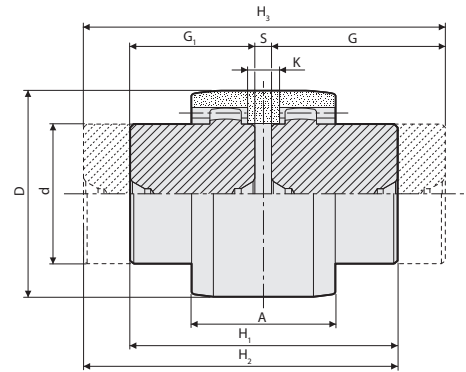
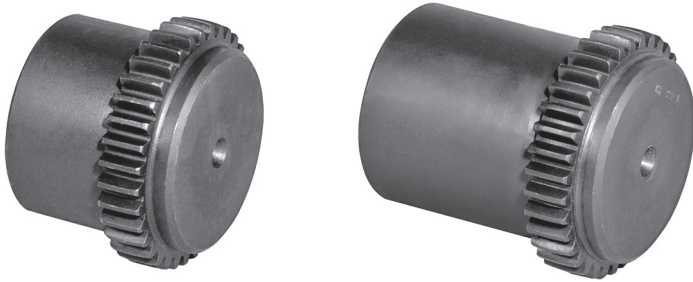

Caratteristiche dentatura / Tothing features / Verzahnungsmerkmale / Caractéristiques de denture / Características de la dentura

Tipo / Type Typ / Type / Tipo	Mod.	Z	Angolo pressione / Pressure angle Eingriffwinkel / Angle de pression / Angulo de presion	De	Dp	Spessore dente / Tooth Width Zahnbreite / Larger denture / Ancho dente
SG-14	1,5	20	20°	33	30	8
SG-19	1,5	24	20°	39	36	8
SG-24	1,5	28	20°	45	42	8
SG-28	1,5	34	20°	54	51	10
SG-32	1,5	40	20°	63	60	10
SG-38	1,5	44	20°	69	66	12
SG-42	1,5	50	20°	78	75	14
SG-48	1,5	50	20°	78	75	14
SG-55	2,0	45	20°	94	90	16
SG-65	2,5	42	20°	110	105	20

Acciaio = C. 43 UNI 7847

Steel = C. 43 UNI 7847

Stahl = C. 43 UNI 7847

Acier = C. 43 UNI 7847

Acero = C. 43 UNI 7847

Esempio codifica

SG-14-CC = con 2 mozzi corti
SG-14-LC = con un mozzo
lungo e uno corto
SG-14-LL = con 2 mozzi lunghi

Code explanation example

SG-14-CC = with 2 hubs short
SG-14-LC = Hub long-short
SG-14-LL = Hub long-long

Kodierungsbeispiel

SG-14-CC = mit 2 kurzen Na-
ben
SG-14-LC = mit einer langen
und einer kurzen Nabe
SG-14-LL = mit 2 langen Na-
ben

Interpretation du code

SG-14-CC = avec 2 moyeux
courts
SG-14-LC = avec un moyeu
long et un court
SG-14-LL = avec 2 moyeux
longs

Ejemplo codificación

SG-14-CC = con 2 cubos cortos
SG-14-LC = con 1 cubo corto y
1 largo
SG-14-LL = con 2 cubos largos

Dimensioni / Dimensions / Abmessungen / Encombremets / Dimensiones
mm

Tipo Type Typ Type Tipo	Foro / Bore Foro / Bore Foro		A	d	G	G ₁	D	S	K	H ₁	H ₂	H ₃	Mozzo corto Short hub Kurze Nabe Moyeu court Cubo corto	Mozzo lungo Long hub Lange Nabe Moyeu long Cubo largo	Manicotto in poliammide Polyamide sleeve Hülse aus Polyamid Manchon en polyamide Manguito en poliamida
	min	max													
SG-14	6	14	37	24	40	23	40	4	6	50	67	84	0,09	0,15	0,02
SG-19	8	19	37	30	40	25	48	4	6	54	69	84	0,15	0,23	0,03
SG-24	10	24	41	36	50	26	52	4	8	56	80	104	0,21	0,40	0,04
SG-28	10	28	46	44	55	40	66	4	9	84	99	114	0,48	0,66	0,07
SG-32	12	32	48	50	55	40	76	4	9	84	99	114	0,63	0,86	0,09
SG-38	14	38	48	58	60	40	83	4	9	84	104	124	0,83	1,25	0,11
SG-42	20	42	50	65	60	42	92	4	9	88	106	124	1,11	1,58	0,14
SG-48	20	48	50	67	60	50	95	4	9	104	114	124	1,37	1,65	0,16
SG-55	25	55	58	82	65	52	114	4	10	108	121	134	2,12	2,66	0,26
SG-65	25	65	68	95	70	55	132	4	12	114	129	144	3,07	3,92	0,39

Quote di montaggio

A richiesta: Foro finito secondo
le norme ISO, tolleranza H7 -
chiavetta DIN 6885, tolleranza
JS9. Foro per grano.

Assembly distances

On request: Finished bore in
compliance with ISO standards,
H7 tolerance - keyway to DIN
6885, JS9 tolerance. Bore for
screws.

Montageabmessungen

Nach Wunsch: Fertigbohrung
nach ISO Normen, Toleranz
H7 - Paßfedernut nach DIN
6885, Toleranz JS9. Gewinde-
bohrung.

Dimensions de montage

Sur demande: Alésage fini selon
normes ISO, tolérance H7 -
Rainure de clavette à DIN 6885,
tolérance JS9. Trou taraudé.

Bajo solicitud

eje acabado según las normas
ISO, tolerancia H7 chavetero
DIN 6885, tolerancia JS9. Eje
con prisonero.



GIUNTI ELASTICI TORSIONALI SG TORSIONAL FLEXIBLE COUPLINGS SG



GIUNTI ELASTICI TORSIONALI ESECUZIONE PRECISA SG CON ELEMENTO ELASTICO

SG FLEXIBLE COUPLINGS IN PRECISE EXECUTION WITH ELASTIC ELEMENT

Introduzione

I giunti elastici torsionali sono costituiti da due mozzi in ghisa che presentano ognuno delle sporgenze sul perimetro esterno che puntano verso il mozzo opposto. I due mozzi si innestano liberamente l'uno nell'altro, e la cavità che si produce al centro viene riempita da un elemento di interposizione in materiale elastomerico a forma di asterisco.

I giunti sono organi di collegamento tra alberi rotanti, e svolgendo questa funzione assicurano contemporaneamente le seguenti prestazioni:

- Rendere la trasmissione esente da urti, smorzando le eventuali vibrazioni dovute al carico o autoindotte
- Attenuare urti e picchi di coppia in fase di avviamento
- Compensare in esercizio leggeri difetti di allineamento tra gli alberi stessi

Per garantire queste prestazioni ad un elevato livello qualitativo e mantenere una buona durata in esercizio, abbiamo curato in modo particolare le lavorazioni, la scelta dei materiali e il controllo finale del prodotto.

Caratteristiche

Caratteristica saliente di questo tipo di giunti è l'elemento di interposizione, determinante per la coppia nominale di ogni giunto.

Il materiale costruttivo dell'elemento di interposizione è di importanza cruciale per la risposta del giunto a fattori di contrasto come vibrazioni, temperatura, agenti chimici, disallineamento, elevati valori di RPM.

La curva che esprime la caratteristica elastica dell'elemento di interposizione deve avere andamento progressivo (cedevole ai bassi valori di coppia e rigido ai valori più elevati) per assicurarne un funzionamento privo di strappi in avviamento ed in cedimento torsionale contenuto a regime. Anche la durata in esercizio del giunto dipende dalla resa elastica del materiale di tale elemento.

A seconda delle applicazioni e delle condizioni di lavoro sarà opportuno scegliere il materiale più appropriato. Nella esecuzione base viene utilizzato per

Introduction

The design of flexible couplings is characterized by two cast iron hubs having each stubby protrusions around their perimeters pointing toward the opposite hub.

The two hubs mesh loosely together, and the gaps between them are filled with blocks of elastomeric material, moulded into an asterisk-shaped element called "spider".

Couplings are elements connecting two rotating shafts, and beyond transmitting power from one shaft to the other they perform the following functions:

- *Ensure a torque transmission free from shocks by damping any torsional vibrations, either due to load or self-induced*
- *Minimize torque shocks and peaks at a starting phase*
- *Compensate for slight angular and parallel shaft misalignments*

In order to guarantee all above performances at a superior quality level while ensuring good service life, chooses only the best materials and arranges for accurate processing and faultless quality control.

General features

In flexible couplings the spider is the element determinant for the torque rating of every coupling. Its constructive material can make a significant difference in the coupling response to contrast factors such as vibration, temperature, chemicals, misalignment, high RPM.

The curve expressing the spider's elasticity must have a progressive trend (yielding at low torque values and rigid at higher torque values) so as to avoid tugs at starting as well as ensure a moderate torsional yielding by regular running.

Also the coupling life depends from the elastic properties of the spider's material.

The choice of the appropriate materials largely depends on the different applications and working conditions.

Allgemeine Beschreibung

Drehelastische Kupplungen bestehen aus zwei kongruenten Kupplungshälften, die innenseitig mit konkav ausgebildeten Klauen versehen sind, die in Umfangsrichtung gegeneinander versetzt stehen und sind so gestaltet, daß in dem Raum dazwischen ein elastischer Zahnkranz eingelegt werden kann.

Kupplungen sind Verbindungselemente zwischen rotierenden Wellen.

Indem sie diese Funktion erfüllen, ermöglichen sie gleichzeitig die folgenden Leistungen:

- Eine stoßfreie Kraftübertragung, mit Dämpfung der durch Belastung verursachten oder selbsterzeugten Schwingungen
- Dämpfung von Stößen und Spitzendrehmomenten in der Anlaufphase
- Ausgleichen von kleinen Fluchtungsfehlern zwischen den Wellen während des Betriebs

Um die obigen Leistungen bei einem hohen Qualitätsniveau zu gewährleisten und eine gute Lebensdauer in Betrieb zu erhalten, werden Werkstoffe sorgfältig gewählt und sämtliche Bearbeitungen sowie die Endkontrolle gewissenhaft ausgeführt.

Technische Merkmale

Das Zwischenglied, entscheidend für das Nenn Drehmoment jeder Kupplung, gilt als springender Punkt dieser Kupplungen.

Der Werkstoff des Zwischengliedes ist maßgebend für eine angemessene Reaktion der Kupplung auf Kontrastfaktoren wie z.B. Schwingungen, Temperatur, Chemikalien, Verlagerung, hohe Drehzahl.

Die Linie, die die elastischen Eigenschaften des Zwischengliedes darstellt, soll einen fortschreitenden Verlauf aufzeigen (nachgiebig bei niedrigen und steif bei höheren Drehmomentwerten), um einen ruckfreien Anlauf sowie einen mäßigen Verdrehnachsen in vollem Betrieb zu sichern.

Zur optimalen Dämpfung der Drehschwingungen weist das Zwischenglied eine der erforderlichen Dämpfungswirkung angemessene elastische Hy-

Description generale

Les accouplements élastiques en torsion sont constitués de deux moyeux en fonte ayant chacun des tenons sur le périmètre extérieur qui pointent vers le moyeu opposé. Les deux moyeux s'engrenent librement l'un dans l'autre, et la cavité qui se produit entre eux est remplie par un élément d'interposition en matière élastomérique en forme d'étoile.

Les accouplements sont organes de jonction entre arbres tournants, et en plus de cette fonction ils assurent en même temps les performances suivantes:

- *Permettre une transmission sans chocs, en amortissant toute vibration due à la charge ou auto-induite*
- *Affaiblir les chocs et les pics de couple en phase de démarrage.*
- *Compenser en service des défauts légers d'alignement entre les arbres mêmes*

Pour garantir ces performances à un haut niveau de qualité tout en maintenant une bonne durée en service, nous avons soigné particulièrement le choix des matériaux, les usinages et le contrôle final du produit.

Caracteristiques

Le trait saillant de ce type d'accouplement est l'élément d'interposition, déterminant pour le couple nominal de chaque accouplement. Le matériau constructif de cet élément a une importance cruciale pour la réponse de l'accouplement aux facteurs de contraste comme les vibrations, la température, les agents chimiques, le désalignement ou valeurs élevées de TPM.

La courbe qui exprime la qualité élastique de l'étoile doit avoir une tendance progressive (flexible avec un petit moment de torsion et rigide avec un moment de torsion élevé) afin d'assurer un démarrage doux et un fléchissement torsionnel modéré, moteur en marche. Même la durée d'exercice de l'accouplement dépend du rendement élastique du matériau constructif de l'étoile.

Le choix du matériau plus approprié doit se faire en suivant les différentes applications et les conditions de travail. Dans la version base on utilise pour l'étoile un elastomère thermoplastique, choisi pour satis-

Introducción

Los acoplamientos elásticos torsionales están formados por dos cubos de fundición cada uno de los cuales presenta salidizos en el perímetro exterior que apuntan hacia el cubo opuesto. Los dos cubos se acoplan libremente el uno dentro del otro y la cavidad que se forma en el centro es llenada por un elemento de interposición en material elastomérico en forma de asterisco.

Los acoplamientos son órganos de conexión entre ejes giratorios, que desarrollando esta función garantizan todas las siguientes prestaciones al mismo tiempo:

- Hacer que la transmisión esté exenta de golpes, amortiguando eventuales vibraciones debidas a la carga o autoinducidas.
- Atenuar golpes y picos de par en fase de arranque.
- Compensar durante el servicio ligeros desperfectos de alineación entre los ejes los mismos ejes.

Para garantizar dichas prestaciones a una elevada calidad manteniendo una buena duración del servicio, hemos puesto especial cuidado en la fabricación, la elección de los materiales y el control final del producto.

Características

La característica principal de este tipo de acoplamientos es el elemento de interposición, que resulta fundamental para el par nominal de cada acoplamiento. El material de construcción del elemento de interposición es sumamente importante para que el acoplamiento responda a factores de contraste tal como vibraciones, temperatura, agentes químicos, desalineación y elevados valores de r.p.m..

La curva que expresa la característica elástica del elemento de interposición debe ser progresiva (flexible a bajos valores de par y rígida con valores de par más elevados) para garantizar un funcionamiento uniforme en fase de arranque y una cesión torsional limitada al régimen. También la duración en servicio del acoplamiento depende del rendimiento elástico del material de dicho elemento.

GIUNTI ELASTICI TORSIONALI ESECUZIONE PRECISA SG CON ELEMENTO ELASTICO

SG FLEXIBLE COUPLINGS IN PRECISE EXECUTION WITH ELASTIC ELEMENT

la corona dentata un elastomero termoplastico scelto per soddisfare esigenze di medio livello. Si tratta di un elastomero di rigidità media, caratterizzato da uno smorzamento interno ottimale, resistente all'invecchiamento, alla fatica, all'abrasione nonché all'idrolisi e ai principali agenti chimici, con particolare riferimenti agli olii e all'ozono. Per i giunti in esecuzione base sono ammesse temperature d'esercizio comprese tra -40°C e +125°C con brevi punte fino a 150°C. Per l'impiego in condizioni di esercizio estreme o comunque per esigenze superiori alla media, sono state studiate e sono disponibili a richiesta mescole alternative in grado di soddisfare ogni necessità pratica.

Il grande vantaggio dei giunti elastici torsionali è che anche in caso di distruzione dell'elemento elastico centrale durante il funzionamento, il sistema continuerà a funzionare con sicurezza evitando così i tempi morti della riparazione di emergenza. L'elemento di interposizione potrà quindi essere sostituito in un momento più opportuno.

Applicazioni

I giunti elastici torsionali sono particolarmente indicati per macchine azionate da motori elettrici in servizio continuo, pompe, riduttori ecc.

Condizioni di impiego e montaggio

I fattori che caratterizzano il funzionamento dei giunti elastici a torsione sono la proporzionalità tra coppia torcente ed angolo di torsione e la capacità di compensare disassamenti angolari e radiali di modesta entità. Valori altrettanto qualificanti ma di più difficile interpretazione sono il fattore di smorzamento e la frequenza naturale o di risonanza. Per la qualificazione dei suoi giunti, la Megadyne dichiara valori di coppia torcente ammissibile correlati a ben definiti valori dell'angolo di torsione che in corrispondenza della coppia massima assume il valore limite di 5°.

Ciò fornisce un valido orientamento circa la progressività della curva elastica.

Per i disassamenti angolare e radiale vengono riportati i valo-

In the basic execution the spider is made of a plastic elastomer selected to meet medium purpose requirements, offering medium rigidity and excellent internal damping, resistant to ageing, fatigue, abrasion, hydrolysis as well as to most common chemicals, such as oils and ozone.

In the basic execution couplings the operating temperatures range from -40°C to +125°C, allowing for short peaks up to 150°C.

For use in extreme working conditions or simply above standard, special compounds have been studied to cope with any type of practical application.

The great advantage of flexible couplings lies in their "failsafe" design, as the coupling is not necessarily destroyed or rendered inoperable if the spider breaks away during operation.

The system will continue to function in safety conditions, preventing critical system downtime, until the spider can be replaced at a more convenient moment.

Applicazioni

Flexible couplings are generally recommended for continuous-duty electric motor-driven machinery, pumps, gearboxes etc.

Installation and use

The main factors affecting the operation of flexible couplings are the proportionality between torque and torsion angle and the capacity to compensate for moderate angular and radial misalignments.

Other important factors, though more difficult to interpret, are damping factor and natural frequency or resonance frequency. For the rating of its couplings, Megadyne states permissible torque values related to precise values of the torsion angle, which assumes the limit value of 5° in connection with the max. torque value.

This provides a good hint about the incremental value of the elastic curve.

The values indicated for angular and radial misalignments are the max. permissible values.

sterese.

Auch die Lebensdauer bei Betrieb der Kupplung wird durch die Rückprall-Elastizität vom Zwischengliedwerkstoff beeinflusst.

Je nach Anwendungsfall und Betriebsverhältnissen muß den geeigneten Werkstoff gewählt werden. In der Grundausführung wird für den Zahnkranz einen plastik-Elastomer verwendet, den für mittlere Betriebsverhältnisse ausgedacht wurde.

Es handelt sich um einen Elastomer mittlerer Härte, der durch eine optimale innere Dämpfung gekennzeichnet ist, verschleiß-, reib und alterungsbeständig, sowie hydrolyse- und chemikalienfest, insbesondere öl- und ozonfest. Für die Kupplungen in Grundausführung wird bei einer Betriebstemperatur zwischen -40°C und +125°C, mit kurzzeitigen Temperaturspitzen bis +150°C, einen einwandfreien Betrieb gesichert.

Im Falle von äußersten oder einfach außerordentlichen Betriebsbedingungen, wurden spezielle Mischungen ausgedacht, die nach Wunsch verfügbar sind, um jeglicher praktischer Anwendung nachzukommen.

Der größte Vorteil an drehelastischen Kupplungen ist ihre Durchschlagsicherheit. Tatsächlich, auch im Fall einer Zerstörung des Zwischen-gliedes während des Betriebs, wird die Anlage weiter in Sicherheit funktionieren, und dadurch werden unnötige Zeitverschwendungen vermieden.

Das Zwischenglied kann dann nachher, in einem günstigerem Augenblick ersetzt werden.

Einsatzbereiche

Drehelastische Kupplungen lassen sich sehr gut in Elektromotorantrieben in Dauerbetrieb, wie z.B. Pumpen und Getrieben, einsetzen

Einsatz- und Einbaubedingungen

Die unterschiedlichen Faktoren für den Betrieb der drehelastischen Kupplungen sind die Proportionalität zwischen Drehmoment und Verdrehwinkel sowie die Fähigkeit, mäßige Winkel- und Radialverlagerungen auszugleichen.

Andere bedeutsame Werte,

faire des exigences de niveau moyen. Il s'agit d'un elastomère de rigidité moyenne, caractérisé par un amortissement intérieur optimal, résistant au vieillissement, à la fatigue, à l'abrasion ainsi qu'à l'hydrolyse et aux agents chimiques les plus communs, et notamment les huiles et l'ozone.

Pour les accouplements en version de base la plage de température admissible est comprise entre -40°C et +125°C avec de brefs pics jusqu'à 150°C. Pour des conditions extrêmes de fonctionnement ou en tous cas pour des exigences supérieures aux normes, des mélanges alternatifs ont été étudiés pour satisfaire toute exigence pratique et sont disponibles sur demande des clients.

Le grand avantage des accouplements élastiques est leur caractéristique "sans échec", c'est à dire qu'en cas de destruction de l'élément élastique central pendant le fonctionnement, l'installation continue à travailler en sécurité, tout en évitant les pertes de temps liées aux dépannages. L'élément d'interposition pourra donc être remplacé dans un moment plus favorable.

Applications

Les accouplements élastiques trouvent leur emploi idéal dans les machines entraînées par des moteurs électriques en service continu, pompes, réducteurs etc.

Conditions de fonctionnement et montage

Les facteurs caractérisant le fonctionnement des accouplements élastiques à torsion sont la proportionnalité entre le couple de torsion et l'angle de torsion, ainsi que la capacité de compenser les défauts d'alignement angulaires et radiaux modérés. Valeurs également qualifiantes mais plus difficiles à interpréter sont le facteur d'amortissement et la fréquence naturelle ou de résonance.

Pour la qualification de ses accouplements, Megadyne déclare des valeurs de couple de torsion admissibles reliées à des valeurs précises de l'angle de torsion qui, en cas de couple maximum, prend la valeur limite de 5°.

Ça donne un indice intéressant quant à la progressivité de la courbe élastique.

Pour les désalignements angulaire et radiaux les valeurs

Según las aplicaciones y las condiciones de trabajo es conveniente elegir el material más adecuado. Durante las ejecuciones de base para la corona dentada se utiliza un elastómero termoplástico elegido para satisfacer exigencias de medio nivel.

Se trata de un elastómero de rigidez media, caracterizado por una amortiguación interior óptima, resistente al envejecimiento, al esfuerzo, a la abrasión, así como a la hidrólisis y a los principales agentes químicos, en particular a los aceites y al ozono.

Durante las ejecuciones de base las temperaturas de servicio permitidas de los acoplamientos deben estar comprendidas entre -40 °C y +125 °C con breves picos de hasta +150 °C.

Para emplearse en condiciones de trabajo extremas y, en general, para exigencias superiores a la media, han sido estudiadas, y están disponibles bajo pedido, mezclas alternativas capaces de satisfacer toda necesidad de tipo práctico.

La gran ventaja de los acoplamientos elásticos torsionales es que también en caso de destrucción del elemento elástico central durante el funcionamiento, el sistema sigue funcionando en condiciones de seguridad, evitando de esta manera los tiempos muertos debidos a las reparaciones de emergencia.

Por lo tanto, el elemento de interposición podrá ser sustituido en un momento más adecuado.

Aplicaciones

Los acoplamientos elásticos torsionales son particularmente indicados para las máquinas accionadas por motores eléctricos de servicio continuo, bombas, reductores etc.

Condiciones de empleo y montaje

Los factores que caracterizan el funcionamiento de los acoplamientos elásticos torsionales son la proporcionalidad entre el par de torsión y el ángulo de torsión y la capacidad de compensar desalineaciones angulares y radiales modestas. Valores igualmente calificantes, aunque de más difícil interpretación, son el factor de

GIUNTI ELASTICI TORSIONALI ESECUZIONE PRECISA SG CON ELEMENTO ELASTICO

SG FLEXIBLE COUPLINGS IN PRECISE EXECUTION WITH ELASTIC ELEMENT

ri massimi ammissibili, con l'avvertenza che si tratta di valori estremi, non cumulabili (solo compensazione angolare o solo compensazione radiale) e validi per condizioni di funzionamento "standard" caratterizzate da: coppia di esercizio non superiore alla coppia nominale, velocità di rotazione inferiore a 1450 giri/min, la massima velocità di rotazione cui corrisponde una velocità periferica massima di 30 m/sec.

Questa velocità può venir raggiunta con sufficiente margine di sicurezza rispetto al pericolo di rottura per sollecitazione a forza centrifuga grazie alle caratteristiche del materiale impiegato.

Nonostante i semigiunti siano completamente lavorati su ogni superficie esterna, si raccomanda la bilanciatura dinamica in classe G 2,5 secondo ISO 1940 qualora la velocità di funzionamento effettivo superi i 2800 giri/min.

Criteri di scelta e dimensionamento del giunto

Il dimensionamento dei giunti viene fatto in base alle leggi fisiche della meccanica e della resistenza dei materiali e risulta per altro conforme a quanto prescritto dalla norma DIN 740 Foglio 2. Per la scelta del giunto vale il criterio per cui anche nelle peggiori condizioni di esercizio non deve mai venir superata la sollecitazione massima ammissibile.

Ne consegue che la coppia nominale dichiarata per il giunto deve venir confrontata con una coppia di riferimento che tenga conto dei sovraccarichi dovuti al modo di agire del carico ed alle condizioni di esercizio. La coppia di riferimento viene ottenuta moltiplicando la coppia di esercizio per una serie di fattori moltiplicativi dipendenti dalla natura del carico o dalle condizioni di temperatura ambiente.

Simboli

- TKN** coppia nominale del giunto
- TK max** coppia max del giunto
- TKw** coppia con inversione del giunto
- TLN** coppia d'esercizio lato condotto
- TLs** coppia di spunto lato condotto

Please consider that they are limit values, not accumulable (either angular or radial compensation), which apply to "standard" working conditions, in which operating torque is not greater than rated torque, rotating speed is not less than 1450 rpm, the highest rotating speed equal to a max rim speed of 30 m/sec.

Thanks to the properties of the material employed, this speed can be reached keeping a sufficient safety margin from the danger of breakdown due to centrifugal force stress. Though each half-coupling is thoroughly machined on all outer surfaces, in case of effective operating speed exceeding 2800 rpm we recommend dynamic balancing of Class 2,5 according to ISO 1940.

Coupling selection and dimensioning

The couplings are dimensioned according to the physical laws of mechanics and material resistance, in compliance with DIN 740 Part 2.

The coupling must be chosen basing on the greatest permissible stress, which shall never be exceeded even in the worst operating conditions.

As a consequence, the rated torque stated for the coupling must be compared with a reference torque taking into account the overloads due to load behaviour and operating conditions.

The reference torque is obtained by multiplying the operating torque by a series of multiplying factors depending on the kind of load or from ambient temperature conditions.

Abbreviations

- TKN** Rated torque
- TK max** Max. torque
- TKw** Torque with coupling reversal
- TLN** Operating torque on driven side
- TLs** Starting torque on driven side
- TAs** Starting torque on driving side
- Ts**

die sich aber schwer auslegen lassen, sind Dämpfungsfaktor und Eigen- bzw. Resonanzfrequenz.

Zur Qualifizierung ihrer Kupplungen gibt Megadyne zulässige Drehmomentwerte an, die im Verhältnis zu gewissen Verdrehwinkelwerten stehen. Bei max. Drehmoment ergibt sich ein maximaler Verdrehwinkel von 5°.

Das bietet wertvolle Anzeichen über den fortschreitenden Verlauf der Biegelinie.

Was die Winkel- und Radialverlagerungen angeht, werden die max. zulässige Werte angegeben, unter Berücksichtigung daß es sich um extreme, nicht kumulierbare Werte handelt (nur Winkel- oder nur Radialverlagerung), die nur für Standardbetriebsverhältnisse gelten, gekennzeichnet durch: Betriebsmoment nicht höher als Nenndrehmoment, Drehgeschwindigkeit kleiner als 1450 Upm, die höchste Geschwindigkeit, der eine Umlaufgeschwindigkeit von 30 m/Sek. entspricht.

Diese Geschwindigkeit kann mit ausreichendem Sicherheits-spielraum erreicht werden, denn die Eigenschaften des eingesetzten Werkstoffs schützen vor Bruchgefahr wegen Beanspruchung durch Zentrifugalkraft.

Obwohl die Kupplungshälfte allseitig bearbeitet sind, sollte die Betriebsgeschwindigkeit 2800 Upm überschreiten, empfehlen wir dynamische Auswuchtung in der Klasse G 2,5 nach ISO 1940.

Berechnungen zur Auswahl und Dimensionierung der Kupplungen

Die Dimensionierung der Kupplungen erfolgt laut den physischen Gesetzen der Mechanik und der Werkstofffestigkeit, und in Anlehnung an DIN 740 Teil 2.

Die Kupplung muß so dimensioniert sein, daß die zulässige Kupplungsbeanspruchung in keinem Betriebszustand überschritten wird.

Daher muß das angegebene Nenndrehmoment der Kupplung mit einem Bezugsdrehmoment verglichen werden, das die durch Lastverhalten und Betriebsverhältnisse bedingten Überlastungen berücksichtigt. Das Bezugs-

rapportées sont les valeurs maximales admissibles, compte tenu qu'il s'agit de valeurs extrêmes, pas cumulables (ou compensation angulaire ou compensation radiale) et valables pour des conditions de fonctionnement "standard" marquée par: couple d'exercice pas supérieur au couple nominal, vitesse de rotation au dessous de 1450 tours/min (la vitesse maximale de rotation à laquelle correspond une vitesse périphérique maximale de 30 m/sec.).

Grâce aux caractéristiques du matériau employé, cette vitesse peut être atteinte avec assez de marge de sécurité par rapport au danger de rupture causée par une contrainte due à la force centrifuge.

Bien que les deux demi-accouplements soient entièrement usinés sur chaque surface extérieure, on recommande l'équilibrage dynamique en classe G 2,5 suivant ISO 1940 lors d'une vitesse de marche dépassant 2800 tours/min.

Principes pour la selection et le dimensionnement des accouplements

Le dimensionnement des accouplements se fait suivant les lois physiques de la mécanique et de la résistance des matériaux, en pleine conformité avec les prescriptions de la norme DIN 740 Partie 2. Pour la sélection de l'accouplement il faut se tenir au critère selon lequel, même dans la pire condition de travail, la contrainte maximale admissible ne doit jamais être dépassée.

Par conséquent le couple nominal déclaré pour l'accouplement doit être comparé avec un couple de référence tenant compte des surcharges dues au comportement de la charge ainsi qu'aux conditions d'exercice. Le couple de référence s'obtient en multipliant le couple d'exercice par une suite de facteurs multiplicatifs qui dépendent du type de la charge ou des conditions de la température ambiante.

Symboles

- TKN** couple nominal de l'accouplement
- TK max** couple max. de l'accouplement
- TKw** couple avec inversion de l'accouplement
- TLN** couple d'exercice côté entraîné
- TLs**

amortiguación y la frecuencia natural o de resonancia.

Para la clasificación de sus acoplamientos Megadyne declara valores de par de torsión permitidos relacionados a valores del ángulo de torsión claramente definidos, que en correspondencia del par máximo asume su valor máximo de 5 grados.

Lo anterior proporciona una orientación válida relativamente a la progresión de la curva elástica.

Por lo que atañe las desalineaciones angular y radial aparecen indicados los valores máximos permitidos, con la advertencia que se trata de los valores extremos, no acumulables sólo compensación angular o sólo compensación radial y válidos para condiciones de empleo de tipo "estándar", caracterizadas por: par de funcionamiento no superior al par nominal, velocidad de rotación inferior a 1.450 r.p.m., la máxima velocidad de rotación a la que corresponde una velocidad periférica máxima de 30 m/seg..

Gracias a las características del material utilizado, dicha velocidad se puede alcanzar con suficiente margen de seguridad con respecto al peligro de rotura debida a la sollicitación de la fuerza centrífuga.

A pesar de que los semiacoplamientos sean completamente trabajados sobre cada superficie externa, se recomienda efectuar el equilibrado dinámico clase G 2,5 según lo establecido por la norma ISO 1940 en caso de que la velocidad de servicio efectivo supere los 2.800 r.p.m..

Criterios de elección y cálculo de dimensiones del acoplamiento

El cálculo de dimensiones de los acoplamientos está basado sobre las leyes físicas de la mecánica y de la resistencia de los materiales y es también conforme según lo dispuesto por la norma DIN 740 Hoja 2. Para la elección del acoplamiento es válido el criterio según el que incluso en las condiciones de trabajo más difíciles no se tiene que superar nunca la sollicitación máxima permitida.

De ello deriva que el par nominal declarado por el acoplamiento debe compararse con un par de referencia que consi-

GIUNTI ELASTICI TORSIONALI ESECUZIONE PRECISA SG CON ELEMENTO ELASTICO

SG FLEXIBLE COUPLINGS IN PRECISE EXECUTION WITH ELASTIC ELEMENT

TAs
coppia di spunto lato motore

Ts
coppia di spunto dell'impianto

PLn
potenza d'esercizio lato condotto

nLn
velocità di rotazione lato condotto (giri 1)

St
fattore di temperatura

SA
fattore d'urto lato motore

SL
fattore d'urto lato condotto

Sz
fattore d'avviamento

SmA
fattore di massa lato comando

Sml
fattore di massa lato condotto

Carico dovuto alla coppia nominale
La coppia nominale ammissibile del giunto TKN deve risultare per qualsiasi temperatura di esercizio eguale o maggiore della coppia di esercizio del lato condotto TLN
TLN=9549 [Nm]

Per tener conto dei sovraccarichi dovuti alla temperatura di esercizio del giunto, dovrà risultare soddisfatta la seguente equazione dove St rappresenta il fattore di temperatura.
TKN => TLN · St

Carico dell'avviamento
Durante il transitorio di avviamento, il motore di comando eroga una coppia motrice multipla della coppia nominale e dipendente dalla distribuzione delle masse. Altrettanto si verifica in fase di frenatura per cui queste due fasi sono caratterizzate da urti di coppia la cui intensità viene a dipendere dalla distribuzione delle masse relative al lato comando SmA ed il lato condotto Sml oltreché dalla frequenza degli avviamenti da cui viene a dipendere il fattore di avviamento Sz.

- lato comando
 $T_s = T_{as} * S_{mA} * S_A$
- lato condotto
 $T_s = T_{Ls} * S_{mL} * S_L$

In prima approssimazione e nel caso non sia nota la distribuzione delle masse, assumere MA e ML eguali ad 1. Per azionamenti tramite motore elettrico il fattore SA può venir assunto pari al rapporto tra coppia di

Starting torque of the system

PLn
Operating power on driven side

nLn
Rotating speed on driven side (1 rotation)

St
Temperature factor

SA
Shock factor on driving side

SL
Shock factor on driven side

Sz
Starting factor

SmA
Mass factor on driving side

Sml
Mass factor on driven side

Load due to rated torque
Regardless of operating temperature, the permissible rated torque of the coupling (TKN) must always be equal to or greater than operating torque on driven side (TLN)
TLN=9549 [Nm]

To take into consideration the overloads due to the coupling operating temperature, the following equation shall be met, in which St stands for temperature factor:
TKN => TLN · St

Load at starting
During starting, the driving motor delivers a driving torque multiple of rated torque and depending on the mass distribution. The same occurs at a breaking phase, so that starting and breaking are marked by torque shocks whose intensity depends on the distribution of masses related to driving side SmA and to driven side Sml, as well as by the starting frequency affecting the starting factor Sz.

- Driving side
 $T_s = T_{as} * S_{mA} * S_A$
- Driven side
 $T_s = T_{Ls} * S_{mL} * S_L$

To simplify, and in case the mass distribution is not known, a rough calculation can be made by considering MA and ML equal to 1.
For electric motor drives SA factor can be considered equal

drehmoment ergibt sich aus der Multiplikation des Betriebsdrehmoments mit gewissen von Belastungsart und Umgebungstemperaturen abhängigen Faktoren.

Symbole

TKN
Nenn Drehmoment

TK max
Maximaldrehmoment

TKw
Wechseldrehmoment

TLN
Betriebsmoment der Lastseite

TLs
Anlaufdrehmoment der Lastseite

TAs
Anlaufdrehmoment der Antriebsseite

Ts
Anlaufdrehmoment der Anlage

PLn
Betriebsleistung der Lastseite

nLn
Drehgeschwindigkeit der Lastseite (1 Umdrehung)

St
Temperaturfaktor

SA
Stoßfaktor der Antriebsseite

SL
Stoßfaktor der Lastseite

Sz
Anlauffaktor

SmA
Massenfaktor der Antriebsseite

Sml
Massenfaktor der Lastseite

Das zulässige Nenn Drehmoment der Kupplung TKN muß bei jeder Betriebs-temperatur gleich oder größer als das Betriebsmoment der Lastseite TLN sein.
TLN=9549 [Nm]

Belastung durch Nenn Drehmoment
Zur Berücksichtigung der von Betriebstemperatur der Kupplung abhängigen Überlastungen, muß die folgende Gleichung, mit St als Temperaturfaktor, erfüllt werden:
TKN => TLN · St.

Belastung durch Anlauf
In der Anlaufphase liefert der Antriebsmotor ein Antriebsdrehmoment vielfach vom Nenn Drehmoment und abhängig von Massenverteilung. Das Gleiche ereignet sich in der Bremsphase, so daß sich beide Phasen durch Drehmomentstöße kennzeichnen, deren

couple de pointe côté entraîné

TAs
couple crête côté entraîné

Ts
couple crête de l'installation

PLn
puissance d'exercice côté entraîné

nLn
vitesse de rotation côté charge (tours 1)

St
facteur de température

SA
facteur de choc côté entraîné

SL
facteur de choc côté entraîné

Sz
facteur de choc côté entraîné

SmA
facteur de masse côté entraîné

Sml
facteur de masse côté charge

Charge due au couple nominal
Le couple nominal admissible de l'accouplement TKN doit résulter pour n'importe quelle température d'exercice égal ou supérieur au couple d'exercice du coté entraîné TLN
TLN=9549 [Nm]

Pour tenir compte des surcharges survenantes à cause de la température d'exercice de l'accouplement, il faudra que l'équation suivante soit satisfaite, où St représente le facteur de température.
TKN => TLN · St

Charge au démarrage
Pendant la phase de démarrage, le moteur d'entraînement dégage un couple moteur multiple du couple nominal et dépendant de la distribution des masses, le même se vérifiant en phase de freinage. Ces deux phases sont donc caractérisées par des chocs de couple ayant une intensité résultante de la distribution des masses relatives au côté entraîné SmA et au côté entraîné Sml outre que de la fréquence des démarrages influant sur le facteur de démarrage Sz.

- côté d'entraînement
 $T_s = T_{as} * S_{mA} * S_A$
- côté entraîné
 $T_s = T_{Ls} * S_{mL} * S_L$

Pour simplifier, et si on ne connaît pas la distribution des masses, prenez MA et ML comme

dere las sobrecargas debidas a la forma de actuar de la carga y a las condiciones de trabajo. El par de referencia se obtiene multiplicando el par de trabajo por una serie de factores multiplicadores que dependen de la naturaleza de la carga o de las condiciones de la temperatura ambiente.

Símbolos

TKN
par nominal del acoplamiento

TK max
par máximo del acoplamiento

TKw
par con inmersión del acoplamiento

TLN
par de trabajo lado conducido

TLs
par de arranque lado conducido

TAs
par de arranque lado conducción

Ts
par de arranque del sistema

PLn
potencia de trabajo lado conducido

nLn
velocidad de rotación lado conducido (giros 1)

St
factor de temperatura

SA
factor de choque lado conducción

SL
factor de choque lado conducido

Sz
factor de arranque

SmA
factor de masa lado conducción

Sml
factor de masa lado conducido

Carga debida al par nominal
Para cualquier temperatura de servicio el par nominal permitido del acoplamiento TKN debe ser igual o superior al par de trabajo del lado conducido TLN
TLN=9549 [Nm]
Para tener en cuenta las sobrecargas debidas a la temperatura de servicio del acoplamiento, es necesario que la siguiente ecuación sea satisfecha, donde St representa el factor de temperatura.
TKN => TLN · St

Carga de arranque
Durante el transitorio de arranque el motor de accionamiento suministra un par motor

GIUNTI ELASTICI TORSIONALI ESECUZIONE PRECISA SG CON ELEMENTO ELASTICO

SG FLEXIBLE COUPLINGS IN PRECISE EXECUTION WITH ELASTIC ELEMENT

spunto e coppia nominale.

Carico dovuto ad urti di coppia

La coppia nominale ammissibile del giunto TKN max deve risultare per qualsiasi temperatura di esercizio eguale o maggiore della coppia di spunto maggiorata del fattore di temperatura St e del fattore di avviamento Sz.

$$TKN_{max} > TS * St * Sz$$

Per condizioni di esercizio che prevedano variazioni periodiche o inversioni di coppia nonché sollecitazioni torsionali alternate consultare l'Ufficio Tecnico della Megadyne.

to the ratio between starting torque and rated torque.

Load due to torque shocks

Regardless of operating temperature, the permissible rated torque of the coupling (TKN max) must be equal to or greater than starting torque increased by temperature factor St and by starting factor Sz.

$$TKN_{max} > TS * St * Sz$$

In case of operating conditions subject to periodic changes or torque reversals as well as to alternate torsional stresses, please contact Megadyne Engineering Dept.

Stärke von Massenverteilung der Antriebsseite SmA und der Lastseite SmL, sowie von der Anlaufhäufigkeit, die den Anlauffaktor Sz bedingt, abhängig ist

- Antriebsseite
 $T_s = T_{as} * S_{mA} * S_A$
- Lastseite
 $T_s = T_{Ls} * S_{mL} * S_L$

Zum vereinfachen, und falls die Massenverteilung nicht bekannt ist, nehmen Sie MA und ML als gleich 1.

Für Elektromotorantriebe kann der Faktor SA als gleich dem Verhältnis zwischen Anlaufdrehmoment und Nenndrehmoment genommen werden.

Belastung durch Drehmomentstöße

Das zulässige Nenndrehmoment der Kupplung TKN muß bei jeder Betriebstemperatur gleich oder größer als das Anlaufdrehmoment erhöht durch Temperaturfaktor St und Anlauffaktor Sz.

$$TKN_{max} > TS * St * Sz$$

Im Fall von Betriebsverhältnissen, die periodische Änderungen oder Drehmomentwechsel sowie abwechselnde Verdrehbeanspruchungen vorsehen, wenden Sie sich bitte an die technische Abteilung von Megadyne.

égaux à 1.

Pour les entraînements moyen-nant moteur électrique le facteur SA peut être considéré comme égal au rapport entre couple crête et couple nominal.

Charge due à chocs de couple

Le couple nominal admissible de l'accouplement TKN max doit être pour n'importe quelle température d'exercice égal ou supérieur au couple crête majoré du facteur de température St et du facteur de démarrage Sz.

$$TKN_{max} > TS * St * Sz$$

Pour des conditions d'exercice qui comportent des variations périodiques ou des inversions de couple ou des contraintes torsionnelles alternées veuillez bien contacter le Bureau Technique de Megadyne.

múltiple del par nominal y dependiente de la distribución de las masas. Otro tanto ocurre durante el frenado, por lo que estas dos fases están caracterizadas por choques de par cuya intensidad depende de la distribución de las masas relativas al lado conducción SmA y al lado conducido SmL, además de la frecuencia de los arranques de los que depende el factor de arranque Sz.

- lado conducción
 $T_s = T_{as} * S_{mA} * S_A$
- lado conducido
 $T_s = T_{Ls} * S_{mL} * S_L$

Por una primera aproximación y en el caso de que no se conozca la distribución de las masas, asumimos que MA y ML son iguales a 1.

Para arranques a través del motor eléctrico, se puede asumir que el factor SA sea equivalente a la relación existente entre el par de arranque y el par nominal.

Carga debida a choques de par

Para cualquier temperatura de servicio el par nominal permitido del acoplamiento TKN máx. debe ser igual o superior al par de arranque incrementado por el factor de temperatura St y el factor de arranque Sz.

$$TKN_{max} > TS * St * Sz$$

Para condiciones de trabajo que requieran variaciones periódicas o inversiones de par así como sollicitaciones torsionales alternas consúltese la Oficina Técnica de Megadyne.

GIUNTI ELASTICI TORSIONALI ESECUZIONE PRECISA SG CON ELEMENTO ELASTICO SG FLEXIBLE COUPLINGS IN PRECISE EXECUTION WITH ELASTIC ELEMENT

		Valori orientativi per fattori di adeguamento Standard values for adjustment factors / Richtwerte für Anpassungsfaktoren Valeurs d'orientation pour les facteurs rajustement / Valores aproximados para los factores de ajuste				
Denominazione Designation / Bezeichnung Dénomination / Denominación	Simbolo Abbreviation / Symbol Symbole / Símbolo	Definizione / Definition / Definition / Définition / Definición				
Fattore di temperatura Temperature factor Temperaturfaktor Facteur de température Factor de temperatura	St.	St. °C	1 -30 +30	1.2 +40	1.4 +80	1.8 +120
Fattore di avviamento Starting factor Anlauffaktor Facteur de démarrage Factor de accionamiento	Sz.	Numero degli avviamenti per ora / Number of starts per hour / Anzahl der Anläufe/Stunde Nombre de démarrage/heure / Numero de arranques por hora				
		Avviamento/h. / Starts/h. / Anläufe/Stunde Démarrages/h. / Arranques / h Sz.	100 1	200 1,2	400 1,4	800 1,6
Fattore d'urto Shock factor Stoßfaktor Facteur de choc Factor de choque	SA/SL	Urti di avviam. leggeri / Slight starting shocks Leichte Anlaufstöße / Chocs faibles au démarrage Choques de arranque ligeros	SA/SL 1,5			
		Urti di avviam. medi / Medium starting shocks Mittelanlaufstöße / Chocs moyens au démarrage Choques de arranque medios	1,8			
		Urti di avviam. pesanti / Heavy starting shcks Achwere Anlaufstöße / Chocs forts au démarrage Choques de arranque fuertes	2,2			

		Fattori Di Servizio / Service factors / Betriebsfaktoren / Facteurs de service / Factores de servicios			
Regime di carico Type of load Belastungsart Type de charge Régimen de carga	Condizioni di impiego Operating conditions Betriebsverhältnisse Conditions de fonctionnement Condiciones de funcionamiento	Tipo di azionamento Type of prime mover Antriebsart Type d'entraînement Tipo de accionamiento			
		Motore elettr. Electric motor Elektromotore Moteur électrique Motor eléctrico	Motore Dies. Diesel engine Dieselmotore Moteur électrique Motor diésel		
Uniforme Uniform Gleichmässig Uniforme Uniforme	Funzionamento regolare senza urti o sovraccarichi. Uniform operation with no shocks or overloads Gleichmäßiger Betrieb ohne Stöße oder Überlastungen Fonctionnement régulier sans chocs ni surcharges Funcionamiento regular sin choques ni sobrecargas	1,25	1,5		
Leggero Light Leicht Légère Ligero	Funzionamento regolare con urti e sovraccarichi leggeri e poco frequenti Uniform operation with slight and sporadic overloads and shocks Gleichmäßiger Betrieb mit leichten gelegentlichen Überlastungen und Stößen Fonctionnement régulier avec des surcharges et des chocs légères et sporadiques Funcionamiento regular con choques y sobrecargas ligeras y esporádicas	1,5	2,0		
Medio Medium Mittel Moyenne Medio	Funzionamento irregolare con sovraccarichi medi di breve durata e urti frequenti ma moderati Irregular operation with medium-intensity, short-lasting overloads and frequent, moderate shocks Ungleichmäßiger Betrieb mit kurzen Überlastungen mittlerer Stärke und häufigen, mäßigen Stößen Fonctionnement irrégulier avec de brefs surcharges de moyenne intensité et de fréquents chocs modérés. Funcionamiento irregular con breves sobrecargas de media intensidad y choques frecuentes pero moderados	2,0	2,5		
Pesante Heavy Schwer Lourde Pesante	Funzionamento decisamente irregolare con urti sovraccarichi molto frequenti e di forte intensità Markedly irregular operation with frequent shocks and overloads of major intensity Entscheidend Ungleichmäßiger Betrieb mit häufigen Stößen und Überlastungen beträchtlicher Stärke Fonctionnement nettement irrégulier avec de fréquents chocs et surcharges de forte intensité Funcionamiento decididamente irregular con choques frecuentes y sobrecargas de fuerte intensidad	2,5	3,0		

GIUNTI ELASTICI TORSIONALI ESECUZIONE PRECISA SG CON ELEMENTO ELASTICO

SG FLEXIBLE COUPLINGS IN PRECISE EXECUTION WITH ELASTIC ELEMENT

Disassamenti

Disalignements

Auslagerungen

Desalignements

Desalineaciones

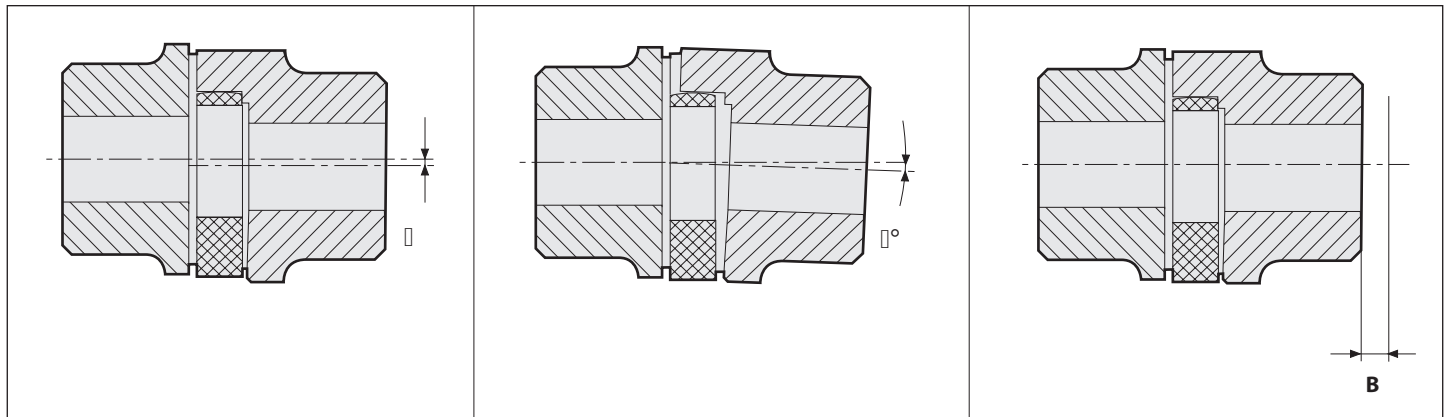

Alberi spostati radialmente
Radial misalignment
Radialverlagerung
Désalignement radial
Desalineación radial

Alberi spostati angolarmente
Angular misalignment
Winkelverlagerung
Désalignement angulaire
Desalineación angular

Alberi spostati assialmente
Axial displacement
Axialverlagerung
Désalignement axial
Desalineación axial

(Stella dentata gialla in poliuretano 92 Shore A)

(Yellow spider in polyurethane 92 Shore A)

(Gelbes Zwischenglied aus Polyurethan 92 Shore A)

(Étoile jaune en polyurethane 92 Shore A)

(Estrella amarilla en poliuretano 92 Shore A)

Dati Tecnici / Technical data / Technische Daten / Données techniques / Datos técnicos

Tipo Type Typ Type Tipo	N. giri max Max. Rpm Max Drehzahl Tpm max r.p.m. máx. (V=30 m/s)	Angolo di torsione Torsion angle Verdrehwinkel Angle de torsion Ángulo de torsión		Stella dentata Spider Zwischenglied Étoile Estrella dentada	Momento torcente (Nm) Torque (Nm) Drehmoment (Nm) Couple (Nm) Par de torsión (Nm)			Rigidità torsionale Torsional rigidity Drehfedersteife Rigidité torsionnelle Rigidez torsional (kNm/rad)				Spostam. assiale Axial displacement Axialverlagerung Déplacement axial Desalineación axial	Disassamento massimo Max. Disalignment Max. Verlagerung Désalignement max. Desalineación máx.		
		TKN	TKmax TKmáx		TKN Norm.	MAX TKmax MAX TKmáx	con Invers. TKW TKW with inv. Wechseldrehm. TKW avec invers. TKW con invers.	1.0	0.75	0.5	0.25		B	Radial	Angol. Angular Winkel Angul Angular
19/24	14000	3.2°	5°	92	10	20	2,6	1,28	1,05	0,80	0,47	1,2	0,20	1,2°	
24/32	10600			92	35	70	9,1	4,86	3,98	3,01	1,79	1,4	0,22	0,9°	
28/38	8500			92	95	190	25,0	10,90	8,94	6,76	4,01	1,5	0,25	0,9°	
38/45	7100			92	190	380	49,0	21,05	17,26	13,05	7,74	1,8	0,28	1,0°	
42/55	6000			92	265	530	69,0	23,74	19,47	14,72	8,73	2,0	0,32	1,0°	
48/60	5600			92	310	620	81,0	36,70	30,09	22,75	13,49	2,1	0,36	1,1°	
55/70	4750			92	410	820	107,0	50,72	41,59	31,45	18,64	2,2	0,38	1,1°	
65/73	4250			92	625	1250	163,0	97,13	79,65	60,22	35,70	2,6	0,42	1,2°	
75/90	3550			92	1280	2560	333,0	113,32	92,92	70,26	41,65	3,0	0,48	1,2°	
90/100	2800			92	2400	4800	624,0	190,09	155,87	117,86	69,86	3,4	0,50	1,2°	

GIUNTI ELASTICI TORSIONALI ESECUZIONE PRECISA SG CON ELEMENTO ELASTICO

SG FLEXIBLE COUPLINGS IN PRECISE EXECUTION WITH ELASTIC ELEMENT

Disassamenti

Disalignments

Auslagerungen

Desalignments

Desalineaciones

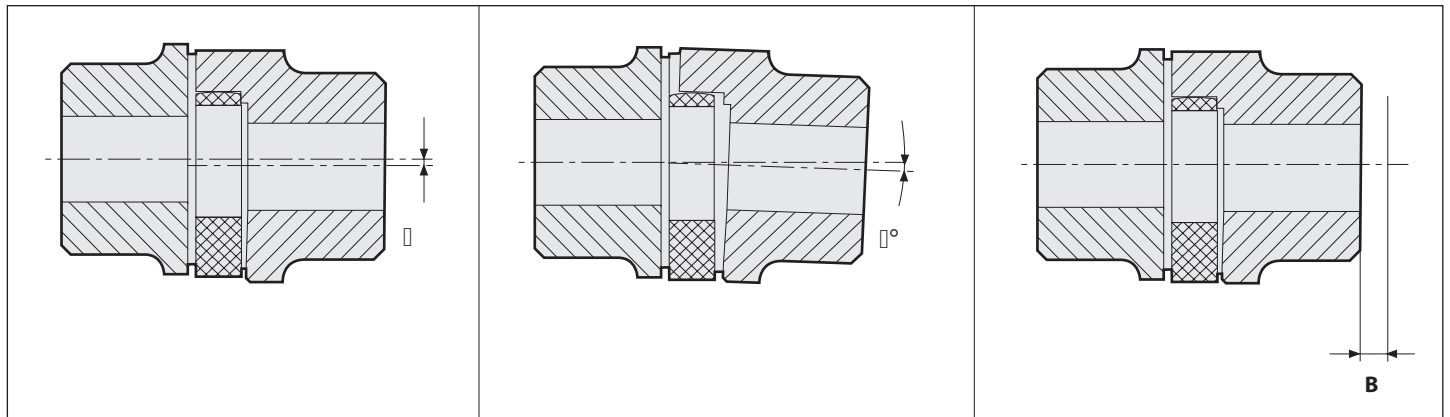

Alberi spostati radialmente
Radial misalignment
Radialverlagerung
Désalignement radial
Desalineación radial

Alberi spostati angolarmente
Angular misalignment
Winkelverlagerung
Désalignement angulaire
Desalineación angular

Alberi spostati assialmente
Axial displacement
Axialverlagerung
Désalignement axial
Desalineación axial

(Stella dentata nera in poliuretano 94 Shore A)

(Black spider in polyurethane 94 Shore A)

(Schwarzes Zwischenglied aus Polyurethan 94 Shore A)

(Étoile noire en polyurethane 94 Shore A)

(Estrella negra en poliuretano 94 Shore A)

Dati Tecnici / Technical data / Technische Daten / Données techniques / Datos técnicos

Tipo Type Typ Type Tipo	N. giri max Max. Rpm Max Drehzahl Tpm max r.p.m. máx. (V=30 m/s)	Angolo di torsione Torsion angle Verdrehwinkel Angle de torsion Ángulo de torsión		Stella dentata Spider Zwischenglied Étoile Estrella dentada	Momento torcente (Nm) Torque (Nm) Drehmoment (Nm) Couple (Nm) Par de torsión (Nm)			Rigidità torsionale Torsional rigidity Drehfedersteife Rigidité torsionnelle Rigidez torsional (kNm/rad)				Spostam. assiale Axial displacement Axialverlagerung Déplacement axial Desalineación axial	Disassamento massimo Max. Disalignment Max. Verlagerung Désalignement max. Desalineación máx.		
		TKN	TKmax TKmáx		TKN Norm.	MAX TKmax MAX TKmáx	con Invers. TKW TKW with inv. Wechseldrehm. TKW avec invers. TKW con invers.	1.0	0.75	0.5	0.25		B	Radial	Angol. Angular Winkel Angul Angular
19/24	14000	3.2°	5°	94	12	24	3,2	1,82	1,49	1,13	0,67	1,2	0,20	1,2°	
24/32	10600			94	43	86	11,4	6,55	5,36	4,06	2,41	1,4	0,22	0,9°	
28/38	8500			94	126	233	30,6	16,19	13,27	10,04	5,95	1,5	0,25	0,9°	
38/45	7100			94	235	470	61,0	30,22	24,78	18,73	11,11	1,8	0,28	1,0°	
42/55	6000			94	326	653	85,0	33,99	27,87	21,07	12,49	2,0	0,32	1,0°	
48/60	5600			94	381	763	99,7	46,23	37,90	28,64	16,99	2,1	0,36	1,1°	
55/70	4750			94	500	1003	130,7	65,47	53,68	40,59	24,06	2,2	0,38	1,1°	
65/73	4250			94	730	1460	190,0	107,92	88,50	66,91	39,66	2,6	0,42	1,2°	
75/90	3550			94	1493	2986	388,3	141,38	115,93	87,65	51,96	3,0	0,48	1,2°	
90/100	2800			94	2800	5600	728,0	230,79	189,24	143,09	84,81	3,4	0,50	1,2°	

GIUNTI ELASTICI TORSIONALI ESECUZIONE PRECISA SG CON ELEMENTO ELASTICO

SG FLEXIBLE COUPLINGS IN PRECISE EXECUTION WITH ELASTIC ELEMENT

Disassamenti

Disalignements

Auslagerungen

Desalignements

Desalineaciones

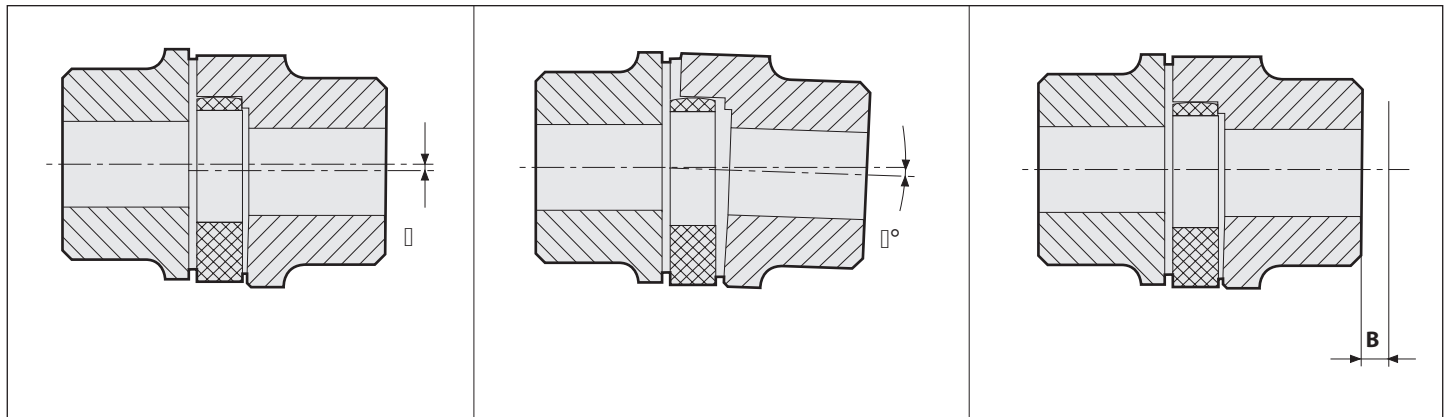

Alberi spostati radialmente
Radial misalignment
Radialverlagerung
Désalignement radial
Desalineación radial

Alberi spostati angolarmente
Angular misalignment
Winkelverlagerung
Désalignement angulaire
Desalineación angular

Alberi spostati assialmente
Axial displacement
Axialverlagerung
Désalignement axial
Desalineación axial

(Stella dentata rossa in poliuretano 98 Shore A)

(Red spider in polyurethane 98 Shore A)

(Rotes Zwischenglied aus Polyurethan 98 Shore A)

(Étoile rouge en polyurethane 98 Shore A)

(Estrella roja en poliuretano 98 Shore A)

Dati Tecnici / Technical data / Technische Daten / Données techniques / Datos técnicos

Tipo Type Typ Type Tipo	N. giri max Max. Rpm Max Drehzahl Tpm max r.p.m. máx. (V=30 m/s)	Angolo di torsione Torsion angle Verdrehwinkel Angle de torsion Ángulo de torsión		Stella dentata Spider Zwischenglied Étoile Estrella dentada	Momento torcente (Nm) Torque (Nm) Drehmoment (Nm) Couple (Nm) Par de torsión (Nm)			Rigidità torsionale Torsional rigidity Drehfedersteife Rigidité torsionnelle Rigidez torsional (kNm/rad)				Spostam. assiale Axial displacement Axialverlagerung Déplacement axial Desalineación axial	Disassamento massimo Max. Disalignment Max. Verlagerung Désalignement max. Desalineación máx.		
		TKN	TKmax TKmáx		TKN Norm.	MAX TKmax MAX TKmáx	con Invers. TKW TKW with inv. Wechsel-drehm. TKW avec invers. TKW con invers.	1.0	0.75	0.5	0.25		B	Radial	Angol. Angular Winkel Angul Angular
19/24	14000	3.2°	5°	98	17	34	4,4	2,92	2,39	1,81	1,07	1,2	0,20	1,2°	
24/32	10600			98	60	120	16,0	9,93	8,14	6,16	3,65	1,4	0,22	0,9°	
28/38	8500			98	160	320	42,0	26,77	21,95	16,60	9,84	1,5	0,25	0,9°	
38/45	7100			98	325	650	85,0	48,57	39,83	30,11	17,85	1,8	0,28	1,0°	
42/55	6000			98	450	900	117,0	54,50	44,69	33,79	20,03	2,0	0,32	1,0°	
48/60	5600			98	525	1050	137,0	65,29	53,54	40,48	24,00	2,1	0,36	1,1°	
55/70	4750			98	685	1370	178,0	94,97	77,88	58,88	34,90	2,2	0,38	1,1°	
65/73	4250			98	940	1880	244,0	129,51	106,20	80,30	47,60	2,6	0,42	1,2°	
75/90	3550			98	1920	3840	499,0	197,50	161,95	122,45	72,58	3,0	0,48	1,2°	
90/100	2800			98	3600	7200	936,0	312,20	256,00	193,56	114,73	3,4	0,50	1,2°	

GIUNTI ELASTICI TORSIONALI SG TORSIONAL FLEXIBLE COUPLINGS SG

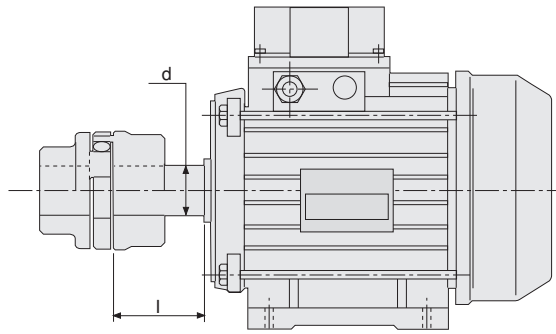

**Giunti SG per motori
normalizzati CEI**

**SG-t couplings
designed for IEC
standardized motors**

**SG Kupplungen für
Motore nach IEC- Nor-
men / Accouplements**

**SG pour moteurs
normalisés CEI**

**Acoplamientos
SG para motores
normalizados CEI**

**(Stella dentata gialla in
poliuretano
92 Shore A)**

**(Yellow spider in
polyurethane
92 Shore A)**

**(Gelbes Zwischenglied
aus Polyurethan
92 Shore A)**

**(Étoile jaune en
polyurethane
92 Shore A)**

**(Estrella amarilla en
poliuretano
92 Shore A)**

Motore elettrico tipo Electric motor type Typ des Elektromotors Moteur électrique Motor eléctrico	Potenza motore a 50 Hz n=3000 min. Motor Output at 50 Hz n=3000 min. Motorleistung bei 50 Hz n=3000 min. Puissance moteur à 50 Hz n=3000 min. Potencia motor a 50 Hz n=3000 min.		Giunto Coupling Kupplung Accouplement Acoplamiento		Potenza motore a 50 Hz n=1500 min. Motor Output at 50 Hz n=1500 min. Motorleistung bei 50 Hz n=1500 min. Puissance moteur à 50 Hz n=1500 min. Potencia motor a 50 Hz n=1500 min.		Giunto Coupling Kupplung Accouplement Acoplamiento		Potenza motore a 50 Hz n=1000 min. Motor Output at 50 Hz n=1000 min. Motorleistung bei 50 Hz n=1000 min. Puissance moteur à 50 Hz n=1000 min. Potencia motor a 50 Hz n=1000 min.		Giunto Coupling Kupplung Accouplement Acoplamiento		Potenza motore a 50 Hz n=750 min. Motor Output at 50 Hz n=750 min. Motorleistung bei 50 Hz n=750 min. Puissance moteur à 50 Hz n=750 min. Potencia motor a 50 Hz n=750 min.		Giunto Coupling Kupplung Accouplement Acoplamiento		Estremità d'albero dx l (mm) Shaft end dx l (mm) Wellenende dx l (mm) Bout d'arbre dx l (mm) Extremos eje dx l (mm)		
	P (kW)	T (Nm)	GET-T TIPO	F _s	P (kW)	T (Nm)	GET-T TIPO	F _s	P (kW)	T (Nm)	GET-T TIPO	F _s	P (kW)	T (Nm)	GET-T TIPO	F _s		3000<1500	
80	0,75	2,4		8,0	0,55	3,6		5,4	0,37	3,6		19/24	5,1	0,18	2,3		19/24	8,0	19x40
90 S	1,10	3,6	19/24	5,4	0,75	4,9	19/24	3,9	0,55	5,4		3,4	0,25	3,2		5,7			
90 L	1,50	4,9		4,0	1,10	7,6		2,7	0,75	7,3		2,5	0,37	4,8		3,8		24x50	
100 L	2,20	7,2		2,7	1,50	9,8		2,0	1,10	10,8		5,8	0,55	7,2		2,5			
112 M	3,00	9,8		7,1	2,20	14,4		4,7		14,7		4,7				6,4			
132 S	4,00	13,1	28/32	3,00	19,6	24/32	3,5					24/32	1,10	14,4	24/32	4,4		28x60	
132 M	5,50	18,0		5,4	4,00	26,2		2,6	2,20	21,6		3,2	1,50	19,7		3,3			
160 M	7,50	24,6		10,6	5,50	36,0		5,3	3,00	29,5		6,3	2,20	28,8		6,6			
180 M	11,00	36,0	24/38	7,6	7,50	49,0	28/38	4,00	39,0	28/38	4,8	3,00	39,0	28/38	4,8			38x80	
200 L	15,00	49,0		7,50	11,00	72,0		3,9	5,50	54,0		3,5	4,00	52,0		4,8			
225 S	18,50	60,0		10,6	11,00	72,0		5,3	7,50	73,0		5,1				7,0			
225 M	22,00	72,0	38/45	7,8	15,00	98,0	38/45	3,9	11,00	108,0	38/45	3,5	5,50	72,0	38/45	5,1		42x110	
250 M	30,00	98,0		6,3	18,50	121,0		4,4					7,50	98,0		3,8			
280 M	37,00	121,0		7,5	22,00	144,0		3,7	15,00	147,0		3,6	11,00	144,0		3,7		48x110	
315 S	44,00	150,0	42/55	5,5	30,00	196,0	42/55	2,7	18,50	182,0	42/55	2,9	15,00	197,0	42/55	2,7		55x110	
315 M	55,00	180,0		4,4	37,00	242,0		2,6	22,00	216,0		2,5							
355 L	65,00	210,0	48/60	2,6	45,00	295,0	48/60	2,1	30,00	295,0	48/60	2,1	18,50	242,0	48/60	2,5			
400 L	75,00	240,0		2,1	55,00	360,0	55/70	2,1	37,0	364,0	55/70	2,1	22,00	288,0		2,1		55x110 60x140	
450 L	85,00	280,0		2,1	75,00	492,0		2,1	45,00	442,0		2,1	30,00	394,0	65	2,2		60x140 65x140	
500 L	95,00	320,0	75	3,1	90,00	590,0	75	4,0	55,00	541,0	75	4,4	37,00	485,0	75	4,0		75x140	
560 L	110,00	360,0	55/70	2,6	110,00	721,0	55/70	3,4	75,00	738,0	55/70	3,6	45,00	591,0		3,3			
630 L	132,00	433,0		2,1	132,00	866,0		2,8	90,00	885,0		2,7	55,00	722,0	75/90	2,7			
710 L	160,00	525,0		2,3	160,00	1030,0	75/90	2,3	110,00	1070,0	75/90	2,3						65x140 80x170	
800 L	200,00	656,0	75/90	4,6	200,00	1290,0	75/90	4,7	132,00	1280,0	75/90	4,5	90,00	1170,0		4,1			
900 L	250,00	820,0		3,0	250,00	1610,0		3,7	160,00	1550,0		3,8	110,00	1420,0		3,4			
1000 L	315,00	1010,0		2,4	315,00	2020,0		3,0	200,00	1930,0	90/100	3,1	132,00	1710,0	70/100	2,8			
1120 L	355,00	1140,0		2,4	355,00	2280,0		2,4	250,00	2420,0	100	2,5	160,00	2070,0		3,2		75x140 95x170	
1250 L	400,00	1280,0	90/100	4,8	400,00	2560,0	90/100	2,9	315,00	3040,0		2,7	200,00	2580,0	100	2,6			
1400 L				3,8				2,9											
1600 L								2,6											80x170 100x210

GIUNTI ELASTICI TORSIONALI SG-M CON MOZZO PIENO

TORSIONAL FLEXIBLE COUPLINGS SG-M WITH SOLID HUB

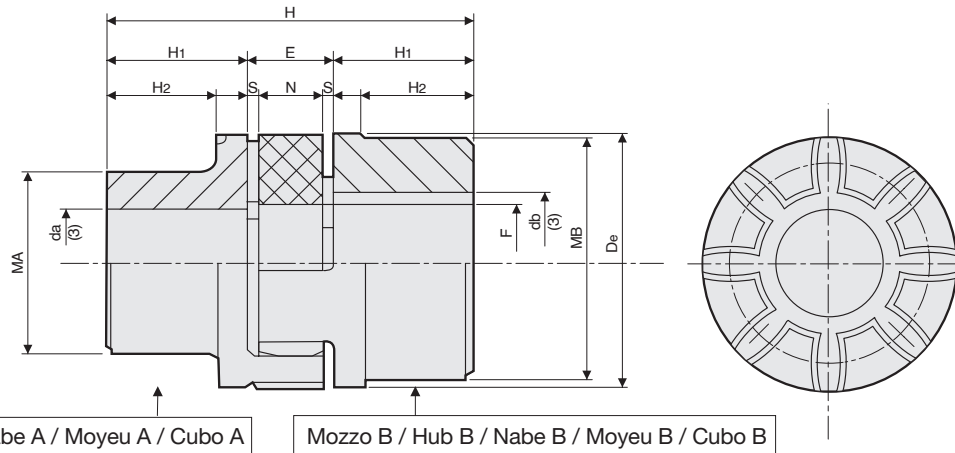

Esempio codifica

SG-M 19A-24B = con mozzo A + mozzo B
 SG-M 19A-19A = con due mozzi A
 SG-M 24B-24B = con due mozzi B
 Il diametro del foro (min-max) identifica la dimensione caratteristica del giunto.

Code explanation example

SG-M 19A-24B = with hub A + hub B
 SG-M 19A-19A = with 2 hubs A type
 SG-M 24B-24B = with 2 hubs B type
 The bore diameter (min-max) identifies the main size of the coupling.

Kodierungsbeispiel

SG-M 19A-24B = mit nabe A + nabe B
 SG-M 19A-19A = mit 2 Naben A
 SG-M 24B-24B = mit 2 Naben B
 Der Nabendurchmesser ((min-max) kennzeichnet die Kupplungshauptgröße.

Interpretation du code

SG-M 19A-24B = avec moyeu A + moyeu B
 SG-M 19A-19A = avec 2 moyeux A
 SG-M 24B-24B = avec 2 moyeux B
 Le diamètre de l'alésage (min-max) marque la taille caractéristique de l'accouplement.

Ejemplo de codificación

SG-M 19A-24B = con cubo A + cubo B
 SG-M 19A-19A = con 2 cubos A
 SG-M 24B-24B = con 2 cubos B
 El diámetro del agujero (min-max) identifica el tamaño característico del acoplamiento.

Materiale ghisa EN-GJL-250 UNI EN 1561

Material cast iron EN-GJL-250 UNI EN 1561

Werkstoff Grauguss EN-GJL-250 UNI EN 1561

Matière fonte EN-GJL-250 UNI EN 1561

Material hierro fundido EN-GJL-250 UNI EN 1561

Tipo Type Typ Type Tipo	Dimensioni / Dimensions / Abmessungen Dimensions / Dimensiones [mm]													Elemento elastico Spider Zwischenglied Annea élastique Elemento elástico	Mozzi / Hubs Naben / Moyeux Cubos		(2) J kg. cm ² Hub B ₁	
	Preforo Pilot bore Vorbohrung Préalésage Taladro previo		(3) Foro Bore Bohrung Alésage Agujero		H ₁	De	(1)		MA	MB	N	H ₂	S		H	A		B
	A	B	da max	db max			E	F										
SG-M 19A-24B*	6	6	19	24	25	40	16	18	30	40	12	19,0	2,0	66	0,004	0,18	0,25	0,8
SG-M 24A-32B	9	9	24	32	30	55	18	27	40	55	14	24,0	2,0	78	0,014	0,36	0,55	3,0
SG-M 28A-38B	10	10	28	38	35	65	20	30	48	65	15	27,5	2,5	90	0,025	0,60	0,85	7,0
SG-M 38A-45B	12	12	38	45	45	80	24	38	66	78	18	36,5	3,0	114	0,042	1,35	1,65	20,0
SG-M 42A-55B	12	12	42	55	50	95	26	46	75	94	20	40,0	3,0	126	0,066	2,00	2,30	50,0
SG-M 48A-60B	12	12	48	60	56	105	28	51	85	104	21	45,0	3,5	140	0,088	2,75	3,10	80,0
SG-M 55A-70B	15	15	55	70	65	120	30	60	98	118	22	52,0	4,0	160	0,116	4,20	4,50	160,0
SG-M 65A-75B	15	15	65	75	75	135	35	68	115	134	26	61,0	4,5	185	0,172	6,50	6,80	310,0
SG-M 75A-90B	15	15	75	90	85	160	40	80	135	158	30	69,0	5,0	210	0,325	10,00	10,80	680,0
SG-M 90A-100B	38	38	90	100	100	200	45	100	160	180	34	81,0	5,5	245	0,440	14,00	15,80	1590,0

* Acciaio

- Quote di montaggio
- Momento d'inerzia giunto con mozzi A/B e ø foro max
- A richiesta: Foro finito secondo le norme ISO, tolleranza H7 – chiave DIN 6885, tolleranza JS9. Foro per grano.

*Steel

- Assembly distances
- Coupling moment of inertia with A/B hubs and max bore ø
- On request: Finished bore in compliance with ISO standards, H7 tolerance - keyway to DIN 6885, JS9 tolerance. Bore for screws.

*Stahl

- Montageabmessungen
- Kupplungsträgheitsmoment mit A/B Naben und max. Bohrungsdurchm.
- Nach Wunsch: Fertigbohrung nach ISO Normen, Toleranz H7 – Paßfedernut nach DIN 6885, Toleranz JS9. Gewindebohrung.

*Acier

- Dimensions de montage
- Moment d'inertie accouplement avec moyeux A/B et ø alésage max.
- Sur demande: Alésage fini selon normes ISO, tolérance H7 – Rainure de clavette à DIN 6885, tolérance JS9. Trou taraudé.

*Acero

- Cotas de montaje
- Momento de inercia acoplamiento con cubos A/B y ø agujero max.
- Bajo solicitud: eje acabado según las normas ISO tolerancia H7 clavetero Din 6885 tolerancia JS9 eji con prisionero

GIUNTI ELASTICI TORSIONALI SG-M CON MOZZO PIENO TORSIONAL FLEXIBLE COUPLINGS SG-M WITH SOLID HUB

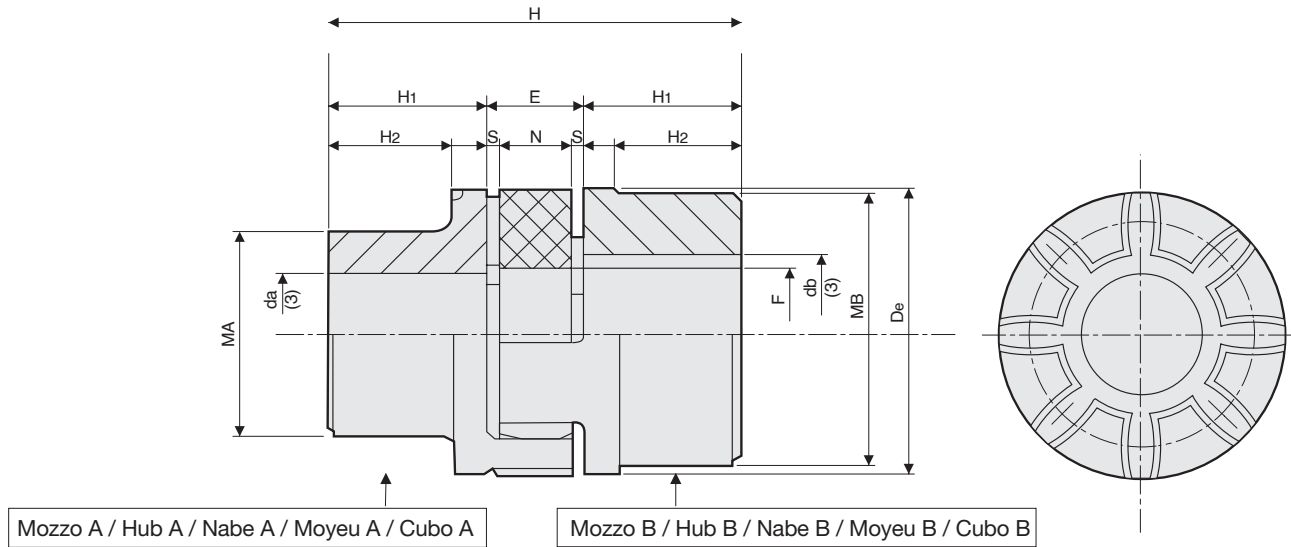

Esempio codifica

SG-M 19A-24B = con mozzo A + mozzo B
SG-M 19A-19A = con due mozzi A
SG-M 24B-24B = con due mozzi B
Il diametro del foro (min-max) identifica la dimensione caratteristica del giunto.

Code explanation example

SG-M 19A-24B = with hub A + hub B
SG-M 19A-19A = with 2 hubs A type
SG-M 24B-24B = with 2 hubs B type
The bore diameter (min-max) identifies the main size of the coupling.

Kodierungsbeispiel

SG-M 19A-24B = mit Nabe A + Nabe B
SG-M 19A-19A = mit 2 Naben A
SG-M 24B-24B = mit 2 Naben B
Der Nabendurchmesser (min-max) kennzeichnet die Kupplungshauptgröße.

Interpretation du code

SG-M 19A-24B = avec moyeu A + moyeu B
SG-M 19A-19A = avec 2 moyeux A
SG-M 24B-24B = avec 2 moyeux B
Le diamètre de l'alésage (min-max) marque la taille caractéristique de l'accouplement.

Ejemplo de codificación

SG-M 19A-24B = con cubo A + cubo B
SG-M 19A-19A = con 2 cubos A
SG-M 24B-24B = con 2 cubos B
El diámetro del agujero (min-max) identifica el tamaño característico del acoplamiento.

Materiale alluminio

Material aluminium

Werkstoff Aluminium

Matière aluminium

Material aluminio

Tipo Type Typ Type Tipo	Preforo Pilot bore Vorbohrung Préalésage Taladro previo		(3) Foro Bore Bohrung Alésage Agujero		Dimensioni / Dimensions / Abmessungen Dimensions / Dimensiones [mm]										Elemento elastico Spider Zwischenglied Annea élastique Elemento elástico		Mozzi / Hubs Naben / Moyeux Cubos		(2) J kg. cm ² Hub B ₁		
					H ₁	De	(1) E	F	MA	MB	N	H ₂	S	H						A	B
SG-M 19A-24B/AL	6	6	19	24	25	40	16	18	30	40	12	19,0	2,0	66	0,005	0,07	0,08	0,4			
SG-M 24A-32B/AL	9	9	24	32	30	55	18	27	40	55	14	24,0	2,0	78	0,014	0,13	0,18	1,0			
SG-M 28A-38B/AL	10	10	28	38	35	65	20	30	48	65	15	27,5	2,5	90	0,025	0,22	0,30	3,0			
SG-M 38A-45B/AL	12	12	38	45	45	80	24	38	66	78	18	36,5	3,0	114	0,042	0,48	0,55	8,0			

(1) Quote di montaggio

(2) Momento d'inerzia giunto con mozzi A/B e ø foro max

(3) A richiesta: Foro finito secondo le norme ISO, tolleranza H7 – chiavetta DIN 6885, tolleranza JS9. Foro per grano.

(1) Assembly distances

(2) Coupling moment of inertia with A/B hubs and max bore ø

(3) On request: Finished bore in compliance with ISO standards, H7 tolerance - keyway to DIN 6885, JS9 tolerance. Bore for screws.

(1) Montageabmessungen

(2) Kupplungsträgheitsmoment mit A/B Naben und max. Bohrungsdurchm.

(3) Nach Wunsch: Fertigbohrung nach ISO Normen, Toleranz H7 – Paßfedernut nach DIN 6885, Toleranz JS9. Gewindebohrung.

(1) Dimensions de montage

(2) Moment d'inertie accouplement avec moyeux A/B et ø alésage max.

(3) Sur demande: Alésage fini selon normes ISO, tolérance H7 – Rainure de clavette à DIN 6885, tolérance JS9. Trou taraudé.

(1) Cotas de montaje

(2) Momento de inercia acoplamiento con cubos A/B y ø agujero max.

(3) Bajo solicitud: eje acabado según las normas ISO tolerancia H7 clavetero Din 6885 tolerancia JS9 eji con prisionero

GIUNTI ELASTICI SG-T PER BUSSOLE CONICHE TORSIONAL FLEXIBLE COUPLINGS SG-T FOR TAPER BUSHES

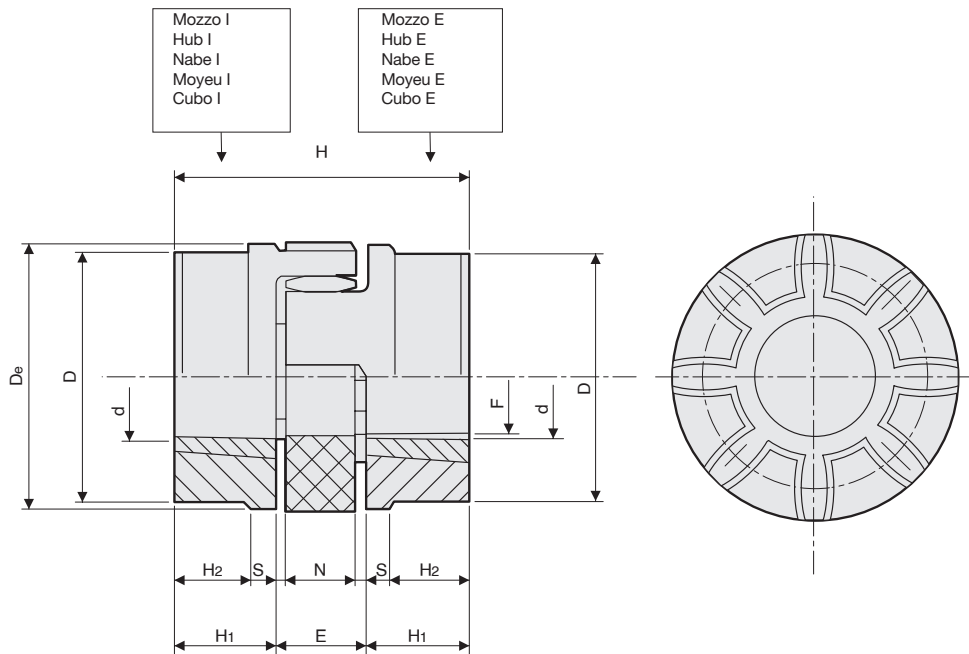

Esempio codifica

SG-T 28-38I / 28-38E = con mozzo I + mozzo E
SG-T 28-38I / 28-38I = con due mozzi I
SG-T 28-38E / 28-38E = con due mozzi E

E = mozzo con bussola esterna
I = mozzo con bussola interna

Code explanation example

SG-T 28-38I / 28-38E = with hub I + hub E
SG-T 28-38I / 28-38I = with 2 hubs I type
SG-T 28-38E / 28-38E = with 2 hubs E type

E = hub with large taper end
I = hub with small taper end

Kodierungsbeispiel

SG-T 28-38I / 28-38E = mit Nabe I + Nabe E
SG-T 28-38I / 28-38I = mit 2 Naben I
SG-T 28-38E / 28-38E = mit 2 Naben E

E = Nabe mit Außenbuchse
I = Nabe mit Innenbuchse

Interpretation du code

SG-T 28-38I / 28-38E = avec moyeu I + moyeu E
SG-T 28-38I / 28-38I = avec 2 moyeux I
SG-T 28-38E / 28-38E = avec 2 moyeux E

E = moyeu avec douille extérieure
I = moyeu avec douille intérieure

Ejemplo de codificación

SG-T 28-38I / 28-38E = con cubo I + cubo E
SG-T 28-38I / 28-38I = con 2 cubos I
SG-T 28-38E / 28-38E = con 2 cubos E

E = cubo con buje exterior
I = cubo con buje interior

Materiale ghisa
EN-GJL-250 UNI EN 1561

Material cast iron EN-GJL-250 UNI EN 1561

Werkstoff Grauguss
EN-GJL-250 UNI EN 1561

Matière fonte
EN-GJL-250 UNI EN 1561

Material hierro fundido
EN-GJL-250 UNI EN 1561

Tipo Type Typ Type Tipo	Foro Bore Bohrung Alésage Agujero		Bussola Bush Buchse Douille Buje	Dimensioni / Dimensions / Abmessungen Dimensions / Dimensiones [mm]										Elemento elastico Spider Zwischenglied Anneau élastique Elemento elástico	Mozzi I/E foro max Max bore for hubs I/E Max. I/E Nabenbohrung Alésage max. moyeux I/E Agujero max. cubos I/E	(2) J kg. cm ² Hub B ₁
	d min	d max		H ₁	De	(1) E	F	D	N	S	H	H ₂				
SGT-T 28-38TL	9	28	1108	23	65	20	30	65	15	2,5	66	-	0,025	0,50	7	
SGT-T 38-45TL	9	28	1108	23	80	24	38	78	18	3,0	70	15	0,042	0,88	26	
SGT-T 42-55TL	10	42	1610	26	95	26	46	94	20	3,0	78	16	0,066	1,40	36	
SGT-T 48-60TL	10	42	1615	39	105	28	51	104	21	3,5	106	28	0,088	2,33	78	
SGT-T 55-70TL	12	50	2012	33	120	30	60	118	22	4,0	96	20	0,116	2,42	120	
SGT-T 75-90TL	16	60	2517	52	160	40	80	158	30	5,0	144	36	0,325	6,80	630	

(1) Quote di montaggio
(2) Momento d'inerzia giunto con mozzi I/E e ø foro max

(1) Assembly distances
(2) Coupling moment of inertia with I/E hubs and max bore ø

(1) Montageabmessungen
(2) Kupplungsträgheitsmoment mit I/E Naben und max. Bohrungsdurchm.

(1) Dimensions de montage
(2) Moment d'inertie accouplement avec moyeux I/E et ø alésage max.

(1) Cotas de montaje
(2) Momento de inercia acoplamiento con cubos I/E y ø agujero max.

GIUNTI SG-HRC SG-HRC COUPLINGS



GIUNTI SG-HRC

SG-HRC COUPLINGS

I giunti **SG-HRC** sono essenzialmente dei giunti per applicazioni generiche, dotati di un elemento flessibile in grado di compensare un elevato grado di disallineamento:

Disallineamento parallelo fino a 0,5 mm

Disallineamento assiale fino a 1,7 mm

Grazie a caratteristiche progettuali di elevata qualità, i giunti **SG-HRC** possono alloggiare alberi di dimensioni maggiori, e presentano quindi interessanti vantaggi economici.

Caratteristiche principali

Progettazione

Il design dei giunti **SG-HRC** è stato ottimizzato in modo che le caratteristiche di potenza siano bilanciate ai diametri specifici degli alberi mediante l'installazione di bussole TL.

Resilienza

I carichi massimi temporanei vengono ridotti grazie ad un componente flessibile, la cui deformazione è un fattore progettuale di importanza cruciale.

Disallineamento

È possibile correggere lo spostamento incidentale parallelo, angolare ed assiale degli alberi collegati.

Installazione

Facile e veloce senza bisogno di utensili speciali, soltanto di un girabrugole.

Manutenzione

È praticamente inesistente e non è richiesto alcun lubrificante.

Fattori ambientali

L'elemento elastico rende i giunti **SG-HRC** adatti all'impiego nella maggior parte delle condizioni a temperatura da -40 a +100 °C.

Vantaggi

Nell'improbabile evento di una distruzione del componente flessibile, la trasmissione verrà mantenuta comunque mediante l'interazione delle bride (denti d'arresto) che integrano le flange.

SG-HRC Couplings are essentially general purpose couplings with a flexible element which can accommodate higher degree of misalignment.

Parallel misalignment upto 0.5 mm

Axial misalignment up to 1.7 mm

Because of their superior design SG-HRC Couplings can accommodate larger shafts which make them a more economical proposition.

Salient features

Economy

The design of the SG-HRC coupling has been optimised so that power capacities are balanced to the appropriate shaft diameters utilising Taper-Lock® Bush fixing.

Resilience

Transient peak loads are reduced by a flexible component, deflection of which is a prime design consideration.

Misalignment

Incidental parallel, angular and axial displacement of the connected shafts can be accommodated.

Installation

Quick and easy without special tools, only an allen key is required.

Maintenance

Virtually eliminated and no lubricant is required.

Environment

The elastomeric component makes SG-HRC coupling suitable for use in most conditions within a temperature range of -40°C to +100°C.

Positive

In the unlikely event of the flexible component being destroyed, the drive will be maintained by the interaction of dogs which are integral with the flanges.

SG-HRC Kupplungen sind grundsätzlich Kupplungen für allgemeine Anwendungen, die mit einem flexiblen Zwischen-glied zum Ausgleichen eines hohen Verlagerungsgrad versehen sind. Parallelverlagerung bis zu 0,5 mm

Axialverlagerung bis zu 1,7 mm

Dank der Auslegung nach neuesten Erkenntnissen, können die **SG-HRC** Kupplungen auch Wellen größerer Abmessungen aufnehmen und weisen daher interessante Preisvorteile auf.

Hauptmerkmale

Planung

Die Planung der **SG-HRC** Kupplungen ist so optimiert worden, daß die unterschiedlichen Leistungsfähigkeiten den spezifischen Wellendurchmessern durch die Montage von Spannbuchsen angemessen sind.

Belastbarkeit

Die max. vorübergehenden Belastungen werden durch ein elastisches Zwischen-glied, deren Verformung als maßgebendes Planungskriterium gilt, reduziert.

Verlagerung

Es ist möglich, die gelegentliche Parallel-, Winkel- und Axialverlagerung der verbundenen Wellen auszugleichen.

Montage

SG-HRC Kupplungen können leicht und schnell ohne Sondergeräte montiert werden, nur mit Hilfe eines Inbusschlüssels.

Wartung

SG-HRC Kupplungen sind praktisch, wartungsfrei und bedürfen keiner Schmierung.

Umgebungsfaktoren

Das elastische Zwischen-glied macht die **SG-HRC** Kupplungen passend für die Verwendung unter den meisten Verhältnissen bei Temperaturen von -40 bis zu +100 °C.

Vorteile (Durchschlagsicherheit)

Auch in dem höchst unwahrscheinlichen Fall einer Zerstörung des Zwischenglieds im Betrieb, wird die Kraftübertragung dank dem Zusammenwirken der Stellklauen mit den Flanschen weiter garantiert werden.

Les accouplements SG-HRC sont essentiellement des accouplements pour applications générales, pourvus d'un élément flexible capable de compenser un haut niveau de désalignement:

Désalignement parallèle jusqu'à 0,5 mm

Désalignement axial jusqu'à 1,7 mm

Grâce à des caractéristiques projectuelles de haut niveau, les accouplements SG-HRC peuvent loger des arbres de plus grandes dimensions et présentent donc des intéressants avantages économiques.

Caractéristiques principales

Conception

La conception des accouplements SG-HRC a été optimisée de telle façon que les caractéristiques de puissance soient proportionnées aux diamètres spécifiques des arbres à travers le montage de moyeux amovibles.

Resilience

Les charges maximales temporaires sont réduites à l'aide d'un composant flexible dont la déformation est un facteur projectuel d'importance cruciale.

Desalignement

Il est possible de corriger le déplacement incident parallèle, angulaire et axial des arbres reliés.

Montage

Facile et rapide sans besoin d'outils spéciaux, mais seulement d'une clé 6 pans.

Entretien

Il est pratiquement éliminé et aucun lubrifiant n'est nécessaire.

Facteurs environnementaux

L'élément élastique rend les accouplements SG-HRC appropriés à l'utilisation dans la plupart des conditions, dans une plage de température de -40° à +100 °C.

Avantages

Au cas très improbable d'une destruction du composant flexible, la transmission sera gardée quand même moyennant l'interaction des dents d'arrêt qui intègrent les flasques.

Los acoplamientos **SG-HRC** son esencialmente acoplamientos de uso general, provistos de un elemento flexible capaz de compensar un elevado nivel de desalineación:

Desalineación paralela hasta 0,5 mm

Desalineación axial hasta 1,7 mm

Gracias a características de elevada calidad específicas del diseño, los acoplamientos **SG-HRC** pueden alojar ejes de dimensiones superiores, ofreciendo por lo tanto interesantes ventajas económicas.

Características principales

Diseño

El diseño de los acoplamientos **SG-HRC** ha sido optimizado de manera que las características de potencia sean equilibradas con respecto a los diámetros específicos de los ejes a través de la instalación de casquillos Cónicos.

Resiliencia

Las cargas máximas temporáneas se reducen gracias a un componente flexible, cuya deformación es un factor de diseño de fundamental importancia.

Desalineación

Es posible corregir el desplazamiento accidental paralelo, angular y axial de los ejes conectados.

Instalación

Fácil y rápida sin necesidad de herramientas especiales, únicamente de un destornillador Allen.

Mantenimiento

Es prácticamente inexistente y no se necesita ningún lubricante.

Factores ambientales

El elemento elástico hace que los acoplamientos **SG-HRC** resulten adecuados para la mayoría de las condiciones a temperaturas oscilantes entre -40° C a +100° C.

Ventajas

En la improbable eventualidad de que el componente flexible se destruyera, la transmisión sería igualmente mantenida a través de la interacción entre los trinquetes (ruedas dentadas) que integran las bridas.

GIUNTI SG-HRC SG-HRC COUPLINGS

Tabella 1 Fattori Di Esercizio	Table 1 Service Factors	Tabelle 1 Betriebsfaktoren	Tableau 1 Facteurs d'exercice	Tabla 1 Factores de Trabajo						
Casi Speciali / Special Cases / Sonderfälle / Cas Speciaux / Casos Especiales										
Tipi Di Trasmissione / Types Of Driving Unit / Antriebsart Types De Transmission / Tipos De Transmisión										
<p>Per applicazioni in cui si verificano urti consistenti, vibrazioni e fluttuazioni della coppia e per macchine con moto alterno, come motori a combustione interna, pompe a pistone e compressori, richiedere alla Megadyne l'analisi torsionale fornendo i dati delle macchine.</p> <p>For applications where substantial shock, vibration and torque fluctuation occur and for reciprocating machines, e.g. internal combustion engines, piston type pumps and compressors, refer to Megadyne with full machine details for torsional analysis</p> <p>Für Anwendungen mit starken Stößen, Vibrationen und Drehmomentschwingungen, Kolbenmaschinen wie Verbrennungsmotoren, Kolbenpumpen und Kompressoren liefert Megadyne gegen Vorlegung der Maschinendaten eine Drehmomentanalyse.</p> <p>Pour les applications dans lesquelles se vérifient des chocs considérables, des vibrations et des fluctuations du couple et pour les machines à piston, comme les moteurs à combustion, pompes et compresseurs à piston, pour avoir l'analyse torsionnelle soumettre à Megadyne les données des machines.</p> <p>Para usos en los que se produzcan choques consistentes, vibraciones y fluctuaciones del par y para máquinas con movimiento alternativo, tal como motores de combustión interna, bombas de pistones compresores, solicítense a Megadyne el análisis torsional proporcionándole los datos de las máquinas.</p>										
Ore di funzionamento giornaliero / Operational hours per day / Betriebsstunden Täglich Heures de fonctionnement par jour / Horas de funcionamiento diarias										
<p>Tipo di azionamento delle macchine / Driven machine class Maschinenantriebsart / Type d'entraînement des machines Tipo de arranque de las máquinas</p>										
<table border="1" style="width: 100%; border-collapse: collapse;"> <tr> <td style="width: 16.6%;">Fino a 8 8 and under Bis 8 Jusqu'à 8 Hasta 8</td> <td style="width: 16.6%;">Da 8 a 16 Over 8 to 16 inclusive 8 bis 16 8 à 16 De 8 a 16</td> <td style="width: 16.6%;">Più di 16 Over 16 Über 16 Plus de 16 Más de 16</td> <td style="width: 16.6%;">Fino a 8 8 and under Bis 8 Jusqu'à 8 Hasta 8</td> <td style="width: 16.6%;">Da 8 a 16 Over 8 to 16 inclusive 8 bis 16 8 à 16 De 8 a 16</td> <td style="width: 16.6%;">Più di 16 Over 16 Über 16 Plus de 16 Más de 16</td> </tr> </table>					Fino a 8 8 and under Bis 8 Jusqu'à 8 Hasta 8	Da 8 a 16 Over 8 to 16 inclusive 8 bis 16 8 à 16 De 8 a 16	Più di 16 Over 16 Über 16 Plus de 16 Más de 16	Fino a 8 8 and under Bis 8 Jusqu'à 8 Hasta 8	Da 8 a 16 Over 8 to 16 inclusive 8 bis 16 8 à 16 De 8 a 16	Più di 16 Over 16 Über 16 Plus de 16 Más de 16
Fino a 8 8 and under Bis 8 Jusqu'à 8 Hasta 8	Da 8 a 16 Over 8 to 16 inclusive 8 bis 16 8 à 16 De 8 a 16	Più di 16 Over 16 Über 16 Plus de 16 Más de 16	Fino a 8 8 and under Bis 8 Jusqu'à 8 Hasta 8	Da 8 a 16 Over 8 to 16 inclusive 8 bis 16 8 à 16 De 8 a 16	Più di 16 Over 16 Über 16 Plus de 16 Más de 16					
<p>Uniforme Agitatori, erogatori di bevande, soffiatori centrifughi e compressori, trasportatori, pompe e ventole centrifughe, generatori, impianti di trattamento dei liquami.</p> <p>Uniform Agitators, Brewing Machinery, Centrifugal Blower and Compressors, Conveyors, Centrifugal Fans and Pumps, Generators, Sewage Disposal Equipment.</p> <p>Gleichmäßig Rührapparate, Getränkeautomaten, Schleudlüfter und -kompressoren, Förderanlagen, Zentrifugalpumpen und -lüfter, Generatoren, Abwasserentsorgungsanlage.</p> <p>Uniforme Agitateurs, distributeurs de boissons, souffleurs et compresseurs centrifuges, transporteurs, pompes et ventilateurs centrifuges, générateurs, unités d'évacuation des eaux usées.</p> <p>Uniforme Agitadores, distribuidor de bebidas, sopladores, centrifugas y compresores, transportadores, bombas y ventiladores centrifugos, generadores, plantas de transformación de abonos orgánicos.</p>										
1,00 1,12 1,25 1,25 1,40 1,60										
<p>Urto moderato* Macchine per la lavorazione dell'argilla, argani a gru, macchine per lavanderia, macchine per lavorazione legno, macchine utensili, mulini rotanti, macchine per cartiere, macchine tessili</p> <p>Moderate shock* Clay working machinery, Cranes Hoist, Laundry machinery, Wood working machinery, Machinery Tools, Rotary Mills, Paper Mill machinery, Textile machinery.</p> <p>Mäßiger Stoß* Tonauflbereitungsmaschinen, Hebezeuge, Wäschereimaschinen, Holzbearbeitungsmaschinen, Werkzeugmaschinen, Walzmühlen, Papiermühlen, Textilmaschinen</p> <p>Choc moderé* Machines pour le traitement de l'argile, machines d'ébénisterie, laveries automatiques, machines outils, moulins rotatifs, machines de papeterie, machines textiles.</p> <p>Choque moderado* Maquinarias para procesar la arcilla, cabrestantes de grúa, maquinarias de lavandería, maquinarias para madera, máquinas-herramienta, molinos giratorios, maquinarias para las fábricas de pasta de papel, máquinas textiles</p>										
1,60 1,80 2,00 2,00 2,24 2,50										
<p>Urto pesante* Trasportatori a moto alterno, frantumatori, scuotitori, mulini metallici, macchine lavorazione gomma, (mescolatori Banbury), compressori a moto alterno.</p> <p>Heavy shock* Reciprocating conveyors, Crushers, Shakers, Metal Mills, Rubber machinery, (Banbury Mixers and Mills), Reciprocating compressors.</p> <p>Starker Stoß* Kolbenförderer, Brecher, Schüttler, Metallmühlen, Gummimaschinen, (Banbury-Mischer), Kolbenkompressoren.</p> <p>Choc lourd* Transporteurs à piston, broyeuses, secoueurs, moulins métalliques, machines pour le traitement du caoutchouc, (mélangeurs et moulins à piston), compresseurs à piston.</p> <p>Choque pesante* Transportadores con movimiento alternativo, trituradores, sacudidores, molinos metálicos, maquinarias para la transformación de caucho, (mezcladores Banbury), compresores con movimiento alternativo.</p>										
2,50 2,80 3,12 3,12 3,55 4,00										

* Si raccomanda di fissare le chiavette (con gioco verticale se in bussole TL) laddove ci si aspetta una fluttuazione del carico

* It is recommended that keys (with top clearance if in Taper Lock Bushes) are fitted for applications where load fluctuation is expected

* Wir empfehlen, daß die Paßfedern (mit vertikalem Spiel bei Spannbuchsen) in den Anwendungen wo eine Lastschwungung vorzusehen ist befestigt werden.

* On recommande de fixer les clavettes (avec jeu vertical dans les moyeux amovibles) dans les applications où on prévoit une fluctuation de la charge

* Se recomienda fijar las chavetas (con juego vertical en casquillos TL) en e caso de que se espere una fluctuación de la carga

GIUNTI SG-HRC

SG-HRC COUPLINGS

Selezione motori elettrici standard

Leggere la tabella 2 e partendo dal telaio del motore trovare la colonna della velocità nominale desiderata. Trovare il giunto appropriato per Taper Lock H o F.

Selection standard electric motors

Read across the table 2 from the appropriate motor frame size and find the applicable nominal motor speed column. Read the appropriate coupling selection for either Taper-Lock[®] H or F.

Auswahl Standard Elektromotoren

Indie Tabelle 2 nachschlagen und je nach Motorbaugröße die Spalte der gewünschten Nenngeschwindigkeit finden. Die Passende Kupplung für die Spannbuchse H oder F finden.

Sélection moteurs électriques standard

Lire le tableau 2 et à partir de la taille du moteur trouver la colonne de la vitesse nominale souhaitée. Trouver l'accouplement approprié pour moyeu amovible H ou F.

Selección motores eléctricos estándar

Leer la tabla 2 y, empezando por el bastidor del motor, encontrar la columna de la velocidad nominal deseada. Encontrar la acoplamiento adecuada para Taper Lock H o F.

Tabella 2
Fattori di esercizio non inferiori a 1,6

Table 2
Service factors not less than 1.6

Tabelle 2
Betriebsfaktoren ab 1,6

Tableau 2
Facteurs de service pas inférieurs à 1,6

Tabla 2
Factores de trabajo no inferiores a 1,6

Grandezza telaio motore Motor Frame Size Motorbaugröße Taille du moteur Tamaño bastidor motor	Diametro albero Shaft Dia. Wellendurchm. Diamètre arbre Diámetro eje en mm	3000 rev/min 3000 rev/min 3000 Umdr./Min 3000 tours/min 3000 rev/min		1500 rev/min 1500 rev/min 1500 Umdr./Min 1500 tours/min 1500 rev/min		1000 rev/min 1000 rev/min 1000 Umdr./Min 1000 tours/min 1000 rev/min		750 rev/min 750 rev/min 750 Umdr./Min 750 tours/min 750 rev/min	
		Potenza motore Motor Power Motorleistung Puissance moteur Potencia motor KW	Grandezza giunto Coupling Size Kupplungsgröße Taille de l'accouplement Tamaño acoplamiento	Potenza motore Motor Power Motorleistung Puissance moteur Potencia motor KW	Grandezza giunto Coupling Size Kupplungsgröße Taille de l'accouplement Tamaño acoplamiento	Potenza motore Motor Power Motorleistung Puissance moteur Potencia motor KW	Grandezza giunto Coupling Size Kupplungsgröße Taille de l'accouplement Tamaño acoplamiento	Potenza motore Motor Power Motorleistung Puissance moteur Potencia motor KW	Grandezza giunto Coupling Size Kupplungsgröße Taille de l'accouplement Tamaño acoplamiento
90 S	24	1,5	70	1,1	70	0,75	70	-	-
90 L	24	2,2	70	1,5	70	1,1	70	-	-
112 M	28	4	90	4	90	2,2	90	1,5	90
132 S	38	5,5	110	5,5	110	3	110	2,2	110
		7,5	110						
132 M	38			7,5	110	4	110	3	110
						5,5	110		
160 M	42	11	110	11	110	7,5	110	4	110
		15	110					5,5	110
160 L	42	18,5	110	15	110	11	130	7,5	110
180 M	48	22	150	18,5	150				
180 L	48			22	150	15	150	11	150
200 L	55	30	180			18,5	180	15	180
		37	180	30	180	22	180		
225 S	60			37	180			18,5	180
225 M	55*	45	180	45	180	30	180	22	180
	60								
250 M	60*	55	180	55	230	37	230	30	230
	65								
280 S	75			75	230	45	230	37	230
280 M	75			90	230	55	230	37	230

*3000 rev/min only.

* 3000 rev/mm only.

* Nur 3000 UPM.

* Seulement 3000 TPM.

*3000 rev/min sólo.

a) Fattore di esercizio

Determinare il fattore di esercizio richiesto da Tabella 1

b) Potenza calcolata

Moltiplicare la normale potenza di funzionamento per il fattore di esercizio per ottenere la potenza calcolata che viene usata come base per la scelta del giunto.

c) Grandezza del giunto

Fare riferimento alla tabella 3 e partendo dalla velocità appropriata nella colonna relativa, cercare una potenza uguale o maggiore alla potenza calcolata richiesta.

d) Dimensioni del foro

Verificare dalla tabella dimensionale 5 che i mozzi prescelti possano accogliere i fori richiesti.

Esempio: Si richiede un giunto per l'albero per trasmettere 70 kW da un motore elettrico da 1440 rpm ad un argano che lavora 16 ore al giorno. L'albero del motore è 70 mm e l'albero dell'argano è 75 mm

a. Fattore di esercizio
Dalla tabella 1, il fattore di esercizio è 2.

b. Potenza calcolata:
 $70 \times 2 = 140 \text{ kW}$

c) Grandezza del giunto
Leggendo la Tabella 3 (Potenze nominali), in corrispondenza della velocità di 1440 rpm si trova la potenza di 143 kW, la prima superiore ai 140 kW della potenza calcolata. La grandezza del giunto in cima a questa colonna è 180.

d) Grandezza del foro

Con riferimento alla Tabella dimensionale 5 si può vedere che per il giunto HRC del tipo 180B entrambi i diametri dell'albero rientrano nel range dei fori disponibili. Tuttavia, nel caso in cui sia necessario scegliere un giunto di tipo per bussola conica, scegliere HRC-230.

a) Service Factor

Determine the required service factor from Table 1.

b) Design Power

Multiply the normal running power by the service factor. This gives the Design Power which is used as a basis for coupling selection.

c) Coupling Size

Refer to Table 3 and from the appropriate speed in the speed column, read across until a power equal to or greater than the design power required is found.

d) Bore Size

From the dimension Table 5 check that the chosen hubs can accommodate the required bores. Registered Trade Mark

Example: A shaft coupling is required to transmit 70kW between a 1440 rev/mm electric motor and a hoist running over 16 hours/day. The motor shaft is 70 mm. and the hoist shaft is 75 mm.

a. Service Factor
From Table 1, the Service Factor is 2.

b. Design Power
Design Power:
 $70 \times 2 = 140 \text{ kW}$

c) Coupling Size
By reading across from 1440 rev/mm in the speed column of Table 3 (Power Rating Table) 143 kW is the first power to exceed the required 140 kW (design power). The size of coupling at the head of this column is 180.

d) Bore Size

By referring to the Dimension table 5 it can be seen that for HRC - 180B type both shaft diameters fall within the bore range available. However in case the coupling selection is required in taper bore then select HRC-230.

a) Betriebsfaktor

Den erforderlichen Betriebsfaktor aus Tabelle 1 bestimmen.

b) Berechnungsleistung

Um die Berechnungsleistung, die als Grund zur Auswahl der Kupplung benutzt wird, zu erhalten, die normale Betriebsleistung mit dem Betriebsfaktor multiplizieren.

c) Kupplungsgröße

Auf Tabelle 3 Bezug nehmen und je nach gewünschter Geschwindigkeit in der entsprechenden Spalte, eine Leistung suchen, die gleich oder größer als die Berechnungsleistung ist.

d) Bohrungsgröße

In der Abmessungstabelle 2 prüfen, ob die gewählten Nabe die erforderlichen Bohrungen aufnehmen können.

Beispiel: Eine Wellenkupplung wird zur Übertragung von 70 kW gebraucht, von einem 1440 Upm Elektromotor zu einem Hebezeug, der 16 Stunden am Tag funktioniert. Die Motorwelle ist 70 mm und die Hebezeugwelle 75 mm

a. Betriebsfaktor
Aus Tabelle 1, der Betriebsfaktor ist 2.

b. Berechnungsleistung:
 $70 \times 2 = 140 \text{ kW}$

c) Kupplungsgröße

In Tabelle 3 (Nennleistungen), entspricht einer Geschwindigkeit von 1440 Upm eine Leistung von 143 kW, die erste Leistung höher als die 140 kW der Berechnungsleistung. Die Kupplungsgröße oben auf dieser Spalte ist 180.

d) Bohrungsgröße

In Bezug auf Abmessungstabelle 5 kann man erkennen, daß für die HRC Kupplung Typ 180B beide Wellendurchmesser in dem Bereich der verfügbaren Bohrungen enthalten sind. Allerdings, falls eine Kupplung der Reihe erforderlich ist, wählen Sie HRC-230 der für spamblichse.

a) Facteur de service

Déterminer le facteur de service requis suivant le Tableau 1

b) Puissance calculée

Multiplier la puissance normale de fonctionnement par le facteur de service afin d'obtenir la puissance calculée qui est utilisée comme point de départ pour le choix de l'accouplement.

c) Taille de l'accouplement

Se référer au tableau 3 et, à partir de la vitesse appropriée dans la colonne relative, chercher une puissance égale ou supérieure à la puissance calculée requise.

d) Taille de l'alésage

Vérifier dans le tableau dimensionnel 5 que les moyeux choisis puissent accueillir les alésages nécessaires.

Exemple: On a besoin d'un accouplement pour transmettre 70 kW d'un moteur électrique de 1440 tpm à un treuil qui travaille 16 heures par jour. L'arbre du moteur est 70 mm et celui du treuil 75 mm

a. Facteur de service
Dans le tableau 1, le facteur de service est 2.

b. Puissance calculée:
 $70 \times 2 = 140 \text{ kW}$

c) Taille de l'accouplement

Lisant le tableau 3 (Puissances nominales), sur la même ligne de la vitesse de 1440 tpm on trouve la puissance de 143 kW, la première puissance supérieure aux 140 kW de la puissance calculée. La taille de l'accouplement en haut de cette colonne est 180.

d) Taille de l'alésage

Se référant au Tableau dimensionnel 5 l'on voit que pour l'accouplement HRC du type 180B tous les deux diamètres de l'arbre rentrent dans la plage des alésages disponibles. Toutefois, au cas où il serait nécessaire de choisir un accouplement du type, choisir HRC-230 moyeux amovibles.

a) Factor de trabajo

Determina el factor de trabajo requerido por la tabla 1.

b) Potencia calculada

Multiplicar la potencia normal de funcionamiento por el factor de trabajo a fin de obtener la potencia calculada que se utiliza como base para elegir el acoplamiento más adecuado.

c) Tamaño del acoplamiento

Hacer referencia a la tabla 3 y empezando por la velocidad apropiada en la columna relativa, buscar una potencia igual o superior a la potencia calculada requerida.

d) Dimensiones del agujero

Controlar en la tabla dimensionale 5 que las cubo seleccionadas puedan acoger los agujeros requeridos.

Ejemplo: se requiere un acoplamiento para el eje a fin de transmitir 70 kW de un motor eléctrico de 1.440 r.p.m. a un cabrestante que funciona durante 16 horas por día. El eje del motor es de 70 mm y el eje del cabrestante es de 75 mm.

a. Factor de trabajo.
De la tabla 1 resulta que el factor de trabajo es 2.

b. Potencia calculada:
 $70 \times 2 = 140 \text{ kW}$

c) Tamaño del acoplamiento

Leyendo la tabla 3 (potencias nominales) en correspondencia de la velocidad de 1.440 r.p.m. se halla la potencia de 143 kW, la primera superior a los 140 kW de la potencia calculada. El tamaño del acoplamiento por encima de esta columna es 180.

d) Tamaño del agujero.

En la tabla dimensional 5 es posible ver que para el acoplamiento HRC del tipo 180B ambos diámetros del eje se encuentran dentro del rango de los agujeros disponibles. Sin embargo, en el caso de que sea necesario elegir entre una acoplamiento de tipo, es preciso elegir la HRC-230 para casquillo conico.

GIUNTI SG-HRC

SG-HRC COUPLINGS

Tabella 3
Potenza nominali (kW)

Table 3
Power ratings (kW)

Tabelle 3
Nennleistungen (KW)

Tableau 3 - Puissances
nominales (kW)

Tabla 3 - Potencia
nominales (kW)

Velocità rev/min Speed rev/min Geschwindigkeit Umdr./Min. Vitesse Tours/Min. Velocidad rev/min	Grandezza giunto / Coupling size / Kupplungsgröße / Taille de l'accouplement / Tamaño acoplamiento							
	70,00	90,00	110,00	130,00	150,00	180,00	230,00	280,00
100	0,33	0,84	1,68	3,30	6,28	9,95	20,90	33,00
200	0,66	1,68	3,35	6,60	12,60	19,90	41,90	66,00
400	1,32	3,35	6,70	13,20	25,10	39,80	83,80	132,00
600	1,98	5,03	10,10	19,80	37,70	59,70	126,00	198,00
720	2,37	6,03	12,10	23,80	45,20	71,60	151,00	238,00
800	2,64	6,70	13,40	26,40	50,30	79,60	168,00	264,00
960	3,17	8,40	16,10	31,70	60,30	95,50	210,00	317,00
1200	3,96	10,10	20,10	39,60	75,40	119,00	251,00	396,00
1440	4,75	12,10	24,10	47,50	90,50	143,00	302,00	475,00
1600	5,28	13,40	26,80	52,80	101,00	159,00	335,00	528,00
1800	5,94	15,10	30,20	59,40	113,00	179,00	377,00	594,00
2000	6,60	16,80	33,50	66,00	126,00	199,00	419,00	660,00
2200	7,26	18,40	36,90	72,60	138,00	219,00	461,00	726,00
2400	7,92	20,10	40,20	79,20	151,00	239,00	503,00	
2600	8,58	21,80	43,60	85,80	163,00	259,00	545,00	
2880	9,50	24,10	48,30	95,00	181,00	286,00		
3000	9,90	25,10	50,30	99,00	188,00	298,00		
3600	11,90	30,10	60,30	118,00	226,00			
Coppia Nominale (Nm) / Nominal Torque (Nm) Nenn Drehmoment (Nm) / Couple nominal (Nm) Par de giro nominal (Nm)	31,50	80	160	315	600	950	2000	3150
Coppia Massima (Nm) / Max Torque (Nm) Max. Drehmoment (Nm) / Couple max (Nm) Par de giro máximo (Nm)	72	180	360	720	1500	2350	5000	7200

Tabella 4
Caratteristiche fisiche

Table 4
Physical characteristics

Tabelle 4
Physische Merkmale

Tableau 4
Caracteristiques Physiques

Tabla 4
Características físicas

Caratteristiche / Characteristic / Merkmale Caractéristiques / Característicos	Grandezza giunto / Coupling size / Kupplungsgröße / Taille de l'accouplement / Tamaño acoplamiento							
	70	90	110	130	150	180	230	280
Velocità Max* RPM / Maximum Speed* rev/min Höchstgeschwindigkeit* UPM / Vitesse Max.*TPM Velocidad max* rev/min	8300	6740	5110	4400	3800	3180	2540	2080
Coppia Nominale (Nm) / Nominal Torque (Nm) Nenn Drehmoment / Couple nominale Par de giro nominal (Nm)	31,5	80	160	315	600	950	2000	3150
Coppia Massima (Nm) / Maximum Torque (Nm) Max. Drehmoment / Couple max. Par de giro máximo (Nm)	72	180	360	720	1500	2350	5000	7200
Disallineamento parallelo Max (mm) / Maximum Parallel Misalignment (mm) / Max. Parallelverlagerung (mm) Désalignement parallèle max. (mm) / Desalineación máxima paralela (mm)	0,3	0,3	0,3	0,4	0,4	0,4	0,5	0,5
Disallineamento assiale Max (mm) Maximum axial Misalignment (mm) / Max. Axialverlagerung (mm) Désalignement axial max (mm) / Desalineación máxima axial (mm)	0,2	0,5	0,6	0,8	0,9	1,1	1,3	1,7

* Le velocità massime del giunto sono calcolate utilizzando la velocità periferica ammissibile per il materiale del mozzo. Per la selezione delle misure più piccole al di sopra dei 3600 rpm rivolgetevi alla Megadyne.

* Maximum coupling speeds are calculated using an allowable peripheral speed for the hub material. For selection of small sizes above 3600 rev/mm - consult Megadyne.

* Max. Kupplungsge-
schwindigkeiten werden
aufgrund der zulässigen
Umlaufgeschwindigkeit
für den Nabenwerkstoff
kalkuliert. Zur Auswahl
von kleineren Größen über
3600 Upm wenden Sie
sich an Megadyne.

* Les vitesses maximales de
l'accouplement sont calcu-
lées en utilisant la vitesse
périphérique admissible pour
le matériau du moyeu. Pour la
sélection des tailles plus pe-
tites en dessus de 3600 Tpm
veuillez bien vous adresser à
Megadyne.

* Las velocidades máximas del
acoplamiento se calculan uti-
lizando la velocidad periferica
permitida para el material del
cubo. Para elegir los tamaños
más pequeños con más de
3600 rpm, consulte con
Megadyne.

GIUNTI ELASTICI SG-HRC-T SERIE CON FORO PER BUSSOLA CONICA ELASTOMERIC SHAFT COUPLING SG-HRC-T TAPER BORE

Tabella 5
Dimensioni

Table 5
Dimensions

Tabelle 5
Abmessungen

Tableau 5
Dimensions

Tabla 5
Dimensiones

Tipo Type Typ Type Tipo	Potenza Power Leistung Puissance Potencia 100 rpm (kW)	Bussola Bush Buchse Douille Buje	Foro minimo Min bore Min bohrung Alésage Min Agujero Min	Foro massimo Max. bore Max. bohrung Alésage max. Agujero máximo	H ₂	B	E	H	J*	Disallineamento massimo Maximum misalignment Max. Verlagerung Désalignement max. Desalineación máxima		Massima rivoluzione n(rpm) Maximum revolution n(rpm) Max. Umdrehung n (Upm) Révolution max. (Tpm) Revolución máxima n (r.p.m.)	Momento d'inertia Moment of inertia Trägheitsmo- ment Moment d'inertie Momento de inercia (kg/cm ³)	De	D	b	G
										Parallelo Parallel Parallel Parallèle Paralela	Assiale Axial Axial Axial Axial						
70	0,33	1008	9	25	20	23,5	25	65	29	0,3	+0,2	9100	8,5	69	60	31	18
90	8,84	1108	9	28	19,5	23,5	30,5	69,5	29	0,3	+0,5	7400	11,5	85	70	32	22,5
110	1,68	1610	14	42	18,5	26,5	45	82	38	0,3	+0,6	5630	40	112	100	45	29
130	3,30	1610	14	42	18	26,5	53	89	38	0,4	+0,8	4850	78	130	105	50	36
150	6,28	2012	14	50	23,5	33,5	60	107	42	0,4	+0,9	4200	181	150	115	62	40
180	9,95	2517	16	60	34,5	46,5	73	142	48	0,4	+1,1	3500	434	180	125	77	49
230	20,90	3020	25	75	39,5	52,5	85,5	165	55	0,5	+1,3	2800	1207	225	155	99	59,5
280	33	3525	35	100	51	66,5	106	208	67	0,5	+1,7	2300	4465	275	206	119	74,5

J = Spazio chiave richiesto per il serraggio e l'allentamento della bussola sull'albero.

J = The wrench clearance required for tightening and loosening the bush on the shaft.

J = Raum für den Schlüssel zur Befestigung und Lockerung der Spannbuchse auf der Welle.

J = Espace requis pour la clé de serrage et desserrage du moyeu sur l'arbre.

J = Ranura para chaveta necesaria para apretar y aflojar el casquillo sobre el eje.

Giunti elastici SG-HRC-M serie con foro cilindrico Elastomeric shaft coupling SG-HRC-M standard straight bore series SG-HRC-M Elastische Kupplungen mit gerader Bohrung Accouplements élastiques SG-HRC-M avec alésages cylindriques Acoplamientos elásticos serie SG-HRC-M con agujero cilíndrico

Tipo Type Typ Type Tipo	Potenza Power Leistung Puissance Potencia 100 rpm (kW)	Foro minimo Min bore Min bohrung Alésage Min Agujero Min	Foro massimo Max. bore Max. bohrung Alésage max. Agujero máximo	H ₂	B	E	H	De	D	b	G
70	0,33	10	32	20	23,5	25,0	65,0	69	60	31	18,0
90	8,84	10	42	26	30,0	30,5	82,5	85	70	32	22,5
110	1,68	10	55	37	45,0	45,0	119,0	112	100	45	29,0
130	3,30	14	60	47	55,5	53,0	147,0	130	105	50	36,0
150	6,28	19	70	50	60,0	60,0	160,0	150	115	62	40,0
180	9,95	35	80	58	70,0	73,0	189,0	180	125	77	49,0
230	20,90	38	100	77	90,0	85,5	239,5	225	155	99	59,5
280	33,00	48	130	90	105,5	105,5	285,5	275	206	119	74,5

GIUNTI ELASTICI SG-HRC-M SERIE CON FORO CILINDRICO ELASTOMERIC SHAFT COUPLING SG-HRC-M STANDARD STRAIGHT BORE SERIES

Materiale Giunto: Ghisa
EN-GJL-250 UNI EN 1561
Materiale Elemento Elasti-
co: Gomma

Coupling Material: Cast Iron
EN-GJL-250 UNI EN 1561
Spider Material: Rubber

Kupplungswerkstoff:
Grauguß EN-GJL-250 UNI
EN 1561
Werkstoff des elastischen
Zwischenglieds: Gummi

Matériau de l'accouple-
ment: fonte EN-GJL-250
UNI EN 1561
Matériau de l'élément élas-
tique: caoutchouc

Material acoplamiento: fun-
dición EN-GJ-250 UNI EN
1561
Material elemento elástico:
goma

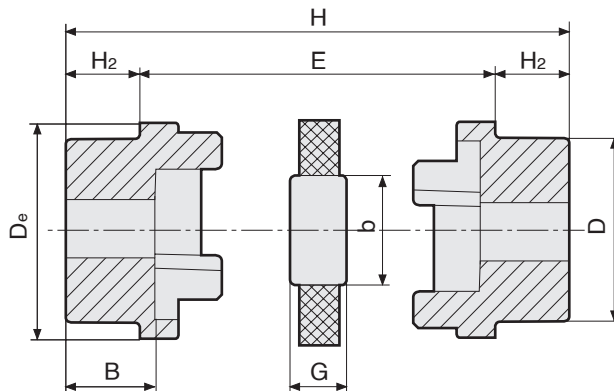

Tipo Type Typ Type Tipo	130 Foro massimo Mozzi / Hubs Max. bore / Max. Nabenbo- hrung / Alésage max. de moyeux / Agujero máximo cubos											
	Dimensioni / Dimensions / Abmessungen / Dimensions / Dimensiones [mm]			De	D	b	E	G	H2	B	H	
	MM	INS										
70	32	1 1/4	69	60	31	25,0	18,0	20,0	23,5	65,0	1,20	
90	42	1 5/8	85	70	32	30,5	22,5	26,0	30,0	82,5	2,15	
110	55	2 1/8	112	100	45	45,0	29,0	37,0	45,0	119,0	6,10	
130	60	2 3/8	130	105	50	53,0	36,0	47,0	55,5	147,0	8,90	
150	70	2 3/4	150	115	62	60,0	40,0	50,0	60,0	160,0	12,20	
180	80	3 1/8	180	125	77	73,0	49,0	58,0	70,0	189,0	18,40	
230	100	4"	225	155	99	85,5	59,5	77,0	90,0	239,5	35,50	
280	130	5"	275	206	119	105,5	74,5	90,0	105,5	285,5	71,50	

GIUNTI ELASTICI SG-HRC-T SERIE CON FORO PER BUSSOLA CONICA ELASTOMERIC SHAFT COUPLING SG-HRC-T TAPER BORE

Materiale Giunto: Ghisa EN-GJL-250 UNI EN 1561
 Materiale Elemento Elastico: Gomma
 Coupling Material: Cast Iron EN-GJL-250 UNI EN 1561
 Spider Material: Rubber
 Kupplungswerkstoff: Grauguß EN-GJL-250 UNI EN 1561
 Werkstoff des elastischen Zwischenglieds: Gummi
 Matériau de l'accouplement: fonte EN-GJL-250 UNI EN 1561
 Matériau de l'élément élastique: caoutchouc
 Material acoplamiento: fundición EN-GJ-250 UNI EN 1561
 Material elemento elástico: goma

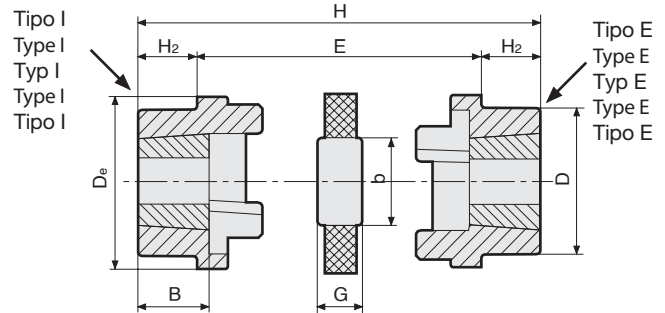

Tipo Type Typ Type Tipo	Bussola Bush Buchse Moyeu Casquillo	Foro massimo Moizzi Hubs Max. bore Max. Naben- bohrung Alésage max. de moyeux Agujero máxi- mo cubos		Dimensioni Dimensions Abmessungen Dimensions Dimensiones [mm]									Disallineamento massimo Maximum misalignment Max. Verlagerung Désalignement max. Desalineación máxima		Massima rivoluzione n(rpm) Maximum revolution n(rpm) Max. Umdrehung n (Upm) Révolution max. (Tpm) Revolución máxima n (r.p.m.)	Momento d'inerzia Moment of inertia Trägheitsmo- ment Moment d'inertie Momento de inerzia (kg/cm ²)	
		MM	INS	De	D	b	E	G	H ₂	B	J	H	Parallelo Parallel Parallel Parallèle Paralela	Assiale Axial Axial Axial Axial			
70	1008	25	1	69	60	31	25,0	18,0	20,0	23,5	29	65,0	0,3	+0,2	9100	8,5	0,88
90	1108	20	1 1/8	85	70	32	30,5	22,5	19,5	23,5	29	69,5	0,3	+0,5	7400	11,5	1,45
110	1610	42	1 5/8	112	100	45	45,0	29,0	18,5	26,5	38	82,0	0,3	+0,6	5630	40,0	3,20
130	1610	42	1 5/8	130	105	50	53,0	36,0	18,0	26,5	38	89,0	0,4	+0,8	4850	78,0	4,54
150	2012	50	2	150	115	62	60,0	40,0	23,5	33,5	42	107,0	0,4	+0,9	4200	181,0	6,60
180	2517	60	2 1/2	180	125	77	73,0	49,0	34,5	46,5	48	142,0	0,4	+1,1	3500	434,0	10,75
230	3020	75	3	225	155	99	85,5	59,5	39,5	52,5	55	165,0	0,5	+1,3	2800	1207,0	19,14
280	3525	100	4	275	206	119	106,0	74,5	51,0	66,5	67	208,0	0,5	+1,7	2300	4465,0	41,00

J = Spazio chiave richiesto per il serraggio e l'allentamento della bussola sull'albero.

J = The wrench clearance required for tightening and loosening the bush on the shaft.

J = Raum für den Schlüssel zur Befestigung und Lockerung der Spannbuchse auf der Welle.

J = Espace requis pour la clé de serrage et desserrage du moyeu sur l'arbre.

J = Ranura para chaveta necesaria para apretar y aflojar el casquillo sobre el eje.

BUSSOLE CONICHE TAPER BUSHES

Le bussole coniche sono il sistema più pratico e conveniente per fissare dei componenti a un albero di trasmissione senza ricorrere ad attrezzature particolari.

Essendo infatti già provviste di foro finito, cava, fori filettati e viti di fissaggio, permettono di risparmiare sui costi e i tempi delle lavorazioni meccaniche speciali.

Tutte le bussole coniche della nostra gamma possono essere utilizzate indifferentemente sui seguenti prodotti:

- Pignoni per catena
- Pulegge a gola
- Pulegge dentate
- Giunti flessibili
- Giunti HRC
- Mozzi saldabili

MONTAGGIO

Assicurarsi che le superfici coniche siano pulite, prive di oli o polveri. Inserire la bussola nella ruota in modo da allineare i fori (1).

Posizionare le viti nei fori filettati, senza stringerle.

Pulire l'albero e quindi montare ruota e bussola nella posizione desiderata, considerando che la bussola stringe prima l'albero e poi la ruota (2).

Stringere le viti prima a mano (3) poi gradualmente e in modo alternato con una chiave esagonale (4). Verificare la chiusura delle viti dopo un breve periodo di funzionamento.

SMONTAGGIO

Allentare tutte le viti e rimuoverne una o due in base al numero dei fori di smontaggio.

Inserire le viti nei fori di smontaggio ed avvitare in modo alternato fino all'allentamento della bussola e fintanto che il gruppo non sia libero sull'albero (5). Rimuovere la bussola e la ruota dall'albero.

Taper bushes are the most convenient and cost effective method of fixing components to a mating shaft without using any special tools.

Taper bushes are already provided with the required bore, keyway, threaded holes and setting screws, thus allowing to save time and money on machining processes.

All taper bushes in our range are designed for use with all the following products:

- Chain sprockets
- V-belt pulleys
- Timing belt pulleys
- Flexible couplings
- HRC couplings
- Weld-on hubs

INSTALLATION

After ensuring that the mating surfaces are clean and free from oil and dirt, insert bush in wheel hub so that holes line up (1).

Place screws loosely in the threaded holes.

Clean shaft and fit assembly to shaft in the position desired, considering that bush will grip the shaft first and then the wheel (2).

Tighten screws first by hand (3), then using an Allen wrench, gradually and alternately (4).

After short time running of the drive, check tightness of screws.

REMOVAL

Loosen all screws and remove one or two according to the number of removal holes. Insert screws into removal holes and tighten them alternately until the bush is loosened and the assembly is free on the shaft (5). Remove assembly from the shaft.

Die Spannbuchsen stellen das praktischste und günstigste System zur Befestigung von Bauteilen auf Antriebswellen dar, ohne dass auf spezielle Einrichtungen zurückgegriffen werden muss.

Da die Spannbuchsen mit Fertigbohrung, Passfedernut, Gewindebohrungen und Befestigungsschrauben schon versehen sind, ermöglichen sie, an Kosten und Zeitaufwand für spezielle maschinelle Bearbeitungen zu sparen.

Alle Spannbuchsen aus unserer Reihe können unterschiedslos auf den folgenden Produkten benutzt werden:

- Kettenräder
- Keilriemenscheiben
- Zahnriemenscheiben
- Drehelastische Kupplungen
- HRC-Kupplungen
- Einschweissnaben

EINBAU

Sicherstellen dass die Kegel­flächen öl- und staubfrei sind, anschließend die Buchse in die Nabe einbauen, und prüfen dass die Bohrungen fluchten (1). Die Befestigungsschrauben in die Gewindebohrungen einsetzen, ohne sie anzuziehen. Die Welle reinigen und die Scheibe zusammen mit der eingesetzten Buchse bis zur gewünschten Lage auf die Welle schieben; dabei beachten, dass die Buchse zuerst an der Welle und dann an der Scheibe spannt (2). Die Befestigungsschrauben zuerst von Hand (3), dann mittels Inbusschlüssel stufenweise und abwechselnd anziehen (4). Nach kurzer Betriebszeit Anzugs­moment der Schrauben überprüfen.

AUSBAU

Alle Schrauben lösen. Je nach der Anzahl an Abdrückbohrungen ein oder zwei Schrauben ganz heraus­schrauben und in die Abdrückbohrungen einschrauben. Die Schraube oder Schrauben abwechselnd anziehen, bis sich die Buchse aus der Nabe löst und die Scheibe sich frei auf der Welle bewegen lässt (5). Scheibe und Buchse von der Welle abnehmen.

Les moyeux amovibles représentent le système plus pratique et convenable pour fixer des composants sur un arbre de transmission sans avoir recours à aucun outil spécial.

Etant déjà pourvus d'alésage, rainure de clavette, trous taraudés et vis de fixation, les moyeux amovibles prêts à monter permettent d'économiser sur les coûts et les temps d'usage.

Tous les moyeux amovibles de notre gamme peuvent être utilisés indifféremment avec les produits suivants:

- Pignons à chaîne
- Poulies trapézoïdales
- Poulies dentées
- Accouplements élastiques
- Accouplements HRC
- Moyeux à souder

MONTAGE

Une fois les surfaces coniques soigneusement nettoyées et dégraissées, introduire le moyeu dans la roue en alignant correctement les taraudages (1).

Mettre en place les vis dans les taraudages, sans les serrer.

Nettoyer l'arbre, et placer l'ensemble roue et moyeu sur l'arbre à l'endroit désiré, en se rappelant que le moyeu bloque d'abord l'arbre et ensuite la roue (2).

Serrer les vis d'abord à la main (3) et ensuite graduellement et alternativement avec une clé à six pans Allen (4).

Vérifier le serrage des vis après quelque temps de fonctionnement.

EXTRACTION

Desserrer toutes les vis et en ôter une ou deux selon le nombre des trous d'extraction. Insérer les vis dans les trous d'extraction et les serrer alternativement jusqu'à ce que le moyeu soit débloqué de la roue et que l'ensemble coulisse librement sur l'arbre (5). Oter l'ensemble roue - moyeu de l'arbre.

Los casquillos conicos son el sistema más práctico y adecuado para fijar unos componentes a un eje de transmisión sin tener que utilizar utilajes particulares. Los caquillos vienen dotados ya de agujero acabado, chavetero, prisioneros y tornillos, permitiendo así de ahorrar tiempo y reducir los gastos de las mecanizaciones especiales.

Todos los casquillos conicos de nuestra gama se pueden utilizar con todos los productos siguientes:

- Piñones por cadena
- Poleas trapezoidales
- Poleas dentadas
- Acoplamiento flexibles
- Acoplamiento HRC
- Cubos soldables

MONTAJE

Asegurarse que las superficies conicas estén limpias, sin aceites o polvos. Introducir el casquillo en la rueda, de manera que los agujeros resulten alineados (1).

Ajustar los tornillos en los prisioneros, sin apretarlos.

Limpiar el eje y después montar rueda y casquillo en la posición deseada, teniendo en cuenta que el casquillo antes aprieta el eje y después la rueda (2).

Apretar los tornillos manualmente (3), después progresivamente y de manera alternada con una llave hexagonal (4).

Averiguar el cierre de los tornillos después de un breve período de marcha.

DESMONTAJE

Soltar todos los tornillos y quitar uno o dos según el número de los agujeros de desmontaje. Introducir los tornillos en los ejes y enroscar de manera alternada hasta la distensión del casquillo, y hasta que el grupo no resulte soltado del eje (5). Quitar el casquillo y la rueda del eje.

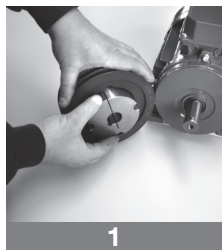

BUSSOLE CONICHE TAPER BUSHES

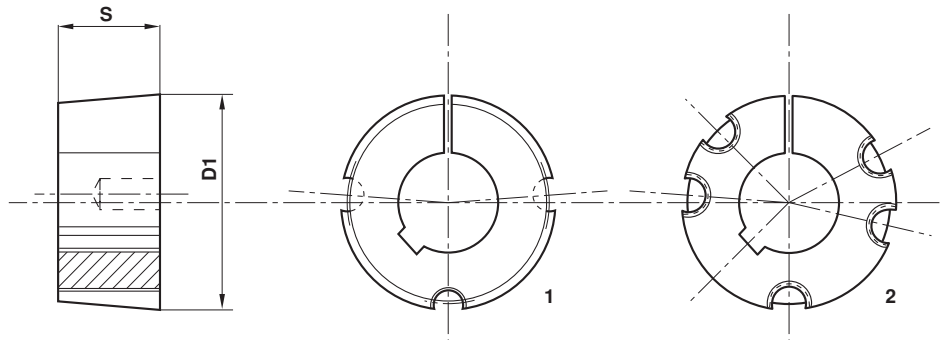
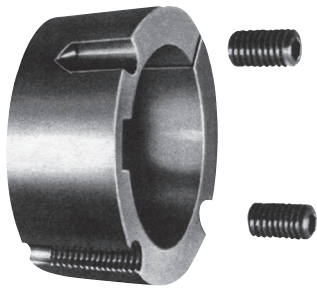

Ghisa
EN-GJL-250 UNI EN 1561

Cast iron
EN-GJL-250 UNI EN 1561

Grauguss
EN-GJL-250 UNI EN 1561

Fonte
EN-GJL-250 UNI EN 1561

Hierro fundido
EN-GJL-250 UNI EN 1561

Fori standard serie metrica

Standard stock bores metric series

Standard Bohrungen metrische Reihe

Alésages standard de stock série métrique

Taladros standard de acopio serie métrica

Esempio: Codice Foro in mm
Ø 14 = 1615014

Example: Code symbol Bore in mm
Ø 14 = 1615014

Beispiel: Bezeichnung Bohrung in mm
Ø 14 = 1615014

Exemple: Code symbole Alesage en mm
Ø 14 = 1615014

Ejemplo: Numero de fabrica Taladros en mm
Ø 14 = 1615014

Tipo bussola Bush type Buchse Typ Moyeux type Casquillos tipo	Cod.	Foro (ISO E 8) Bore (ISO E 8) Bohrung (ISO E 8) Alesage (ISO E 8) Taladro (ISO E 8) mm	Coppia trasmissibile Transmissible torque übertragbares Drehmoment Couple transmissible Cupla de transmission Nm	Viti Screws Schrauben Vis Tornillo B.S.W.	Coppia di serraggio viti Screw tightening torque Anzugsmoment Schrauben Couple de serrage des vis Par de apriete tornillos Nm	D1 mm	Typo Type Typ Type Tipo	S mm	Peso Weight Gewicht Poids Peso Kg
1008	1008...	9 10 11 12 14 15 16 18 19 20 22 24* 25*	136	1/4" x 1/2"	5,6	35,0	1	22,3	0,16
1108	1108...	9 10 11 12 14 15 16 18 19 20 22 24 25 28*	147	1/4" x 1/2"	5,6	38,0	1	22,3	0,16
1210	1210...	11 12 14 15 16 18 19 20 22 24 25 28 30 32	407	3/8" x 5/8"	19,6	47,5	1	25,4	0,32
1215	1215...	14 19 20 24 25 28	407	3/8" x 5/8"	19,6	47,5	1	38,1	0,50
1610	1610...	14 15 16 18 19 20 22 24 25 28 30 32 35 38 40 42*	486	3/8" x 5/8"	19,6	57,0	1	25,4	0,41
1615	1615...	14 16 18 19 20 22 24 25 28 30 32 35 38 40 42*	486	3/8" x 5/8"	19,6	57,0	1	38,1	0,60
2012	2012...	14 16 18 19 20 22 24 25 28 30 32 35 38 40 42 45 48 50	808	7/16" x 7/8"	30,4	70,0	1	31,8	0,75
2517	2517...	16 18 19 20 22 24 25 28 30 32 35 38 40 42 45 48 50 55 60 65*	1310	1/2" x 1"	48	85,5	1	44,5	1,06
3020	3020...	25 28 30 32 35 38 40 42 45 48 50 55 60 65 70 75	2710	5/8" x 1 1/4"	90	108,0	1	50,8	2,50
3030	3030...	35 38 40 42 45 48 50 55 60 65 70 75	2710	5/8" x 1 1/4"	90	108,0	1	76,2	3,75
3525	3525...	35 38 40 42 45 48 50 55 60 65 70 75 80 85 90	5060	1/2" x 1 1/2"	112	127,0	2	64,9	4,20
3535	3535...	35 38 40 42 45 48 50 55 60 65 70 75 80 85 90	5060	1/2" x 1 1/2"	112	127,0	2	88,9	5,13
4030	4030...	40 42 45 48 50 55 60 65 70 75 80 85 90	8740	5/8" x 1 3/4"	169	146,0	2	76,2	6,75
4040	4040...	40 42 45 48 50 55 60 65 70 75 80 85 90 95	8740	5/8" x 1 3/4"	169	146,0	2	101,6	7,68
4535	4535...	65 70 75 80 85 90 95 100 110 120	12400	3/4" x 2"	192	162,0	2	89,0	9,95
4545	4545...	55 60 65 70 75 80 85 90 95 100 110	12400	3/4" x 2"	192	162,0	2	115,0	10,56
5040	5040...	70 75 80 85 90 95 100 105 110 115 120 125	14200	7/8" x 2 1/4"	271	177,6	2	101,6	14,20
5050	5050...	70 75 80 85 90 95 100 105 110 115 120 125	14200	7/8" x 2 1/4"	271	177,6	2	127,0	15,17

Dimensioni delle cave (UNI 6604 DIN 6885) con foro standard serie metrica

Dimensions of keyways (UNI 6604 DIN 6885) with standard bore metric series

Abmessungen der Keilnuten (UNI 6604 DIN 6885) mit Standardbohrung metrische Reihe

Dimens. des rainures de clavette (UNI 6604 DIN 6885) dans le moyeux avec alésage stand. série métrique

Medidas de los chaveteros (UNI 6604 DIN 6885) con agujero standard serie métrica

D	b	Js9	t	Dimensioni delle cave ribassate Dimensions of low profile keyways Abmessungen der abgefachten Keilnuten Dimensions des rainures de clavette surbaissées Medidas de los chaveteros rebajados		
Over 10 to 12	4		D + 1,8	D*	b	t
» 12 » 17	5	± 0,015	D + 2,3			
» 17 » 22	6		D + 2,8	24*	8	D + 1,3
» 22 » 30	8		D + 3,3			
» 30 » 38	10	± 0,018	D + 3,3	25*	8	D + 1,3
» 38 » 44	12		D + 3,3			
» 44 » 50	14		D + 3,8	28*	8	D + 1,3
» 50 » 58	16	± 0,021	D + 4,3			
» 58 » 65	18		D + 4,4	42*	12	D + 1,3
» 65 » 75	20		D + 4,9			
» 75 » 85	22		D + 5,4	65*	18	D + 2,8
» 85 » 95	25	± 0,026	D + 5,4			
» 95 » 110	28		D + 6,4			
» 110 » 130	32	± 0,031	D + 7,4			

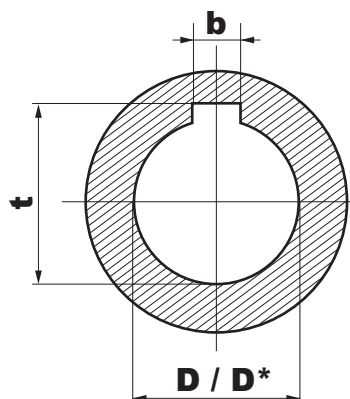

BUSSOLE CONICHE TAPER BUSHES

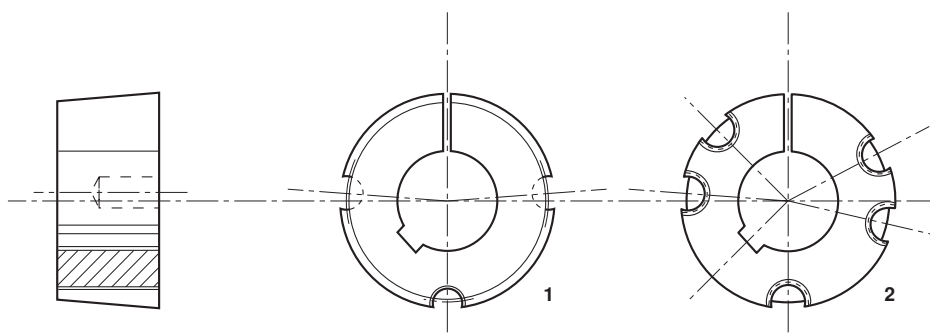
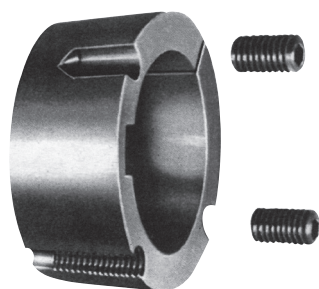

Ghisa
EN-GJL-250 UNI EN 1561

Cast iron
EN-GJL-250 UNI EN 1561

Grauguss
EN-GJL-250 UNI EN 1561

Fonte
EN-GJL-250 UNI EN 1561

Hierro fundido
EN-GJL-250 UNI EN 1561

Fori standard in pollici

Standard stock bores series in inches

Standard Bohrungen Reihe in Zoll

Alésages standard de stock série en pouces

Taladros standard de acopio en pulgadas

Tipo bussola Bush type Buchse typ Moyeux Type Casquillos tipo	Cod.	Foro in pollici (ISO E 8) Bore in inches (ISO E 8) Bohrung in Zoll (ISO E 8) Alésage en pouces (ISO E 8) Taladro en pulgadas (ISO E 8)
1008	1008...	3/8" - 1/2" - 5/8" - 3/4" - 7/8" - 1" *
1108	1108...	3/8" - 1/2" - 5/8" - 3/4" - 7/8" - 1" - 1"1/8"
1210	1210...	1/2" - 5/8" - 3/4" - 7/8" - 1" - 1"1/8" - 1"1/4"
1215	1215...	1/2" - 5/8" - 3/4" - 7/8" - 1" - 1"1/8" - 1"1/4"
1610	1610...	1/2" - 5/8" - 3/4" - 7/8" - 1" - 1"1/8" - 1"1/4" - 1"3/8" - 1"1/2" - 1"5/8"
1615	1615...	1/2" - 5/8" - 3/4" - 7/8" - 1" - 1"1/8" - 1"1/4" - 1"3/8" - 1"1/2" - 1"5/8"
2012	2012...	3/4" - 7/8" - 1" - 1"1/8" - 1"1/4" - 1"3/8" - 1"1/2" - 1"5/8" - 1"3/4" - 1"7/8" - 2"
2517	2517...	3/4" - 7/8" - 1" - 1"1/8" - 1"1/4" - 1"3/8" - 1"1/2" - 1"5/8" - 1"3/4" - 1"7/8" - 2" - 2"1/8" - 2"1/4" - 2"3/8" - 2"1/2"
3020	3020...	1"1/4" - 1"3/8" - 1"1/2" - 1"5/8" - 1"3/4" - 1"7/8" - 2" - 2"1/8" - 2"1/4" - 2"3/8" - 2"1/2" - 2"5/8" - 2"3/4" - 2"7/8" - 3"
3030	3030...	1"1/4" - 1"3/8" - 1"1/2" - 1"5/8" - 1"3/4" - 1"7/8" - 2" - 2"1/8" - 2"1/4" - 2"3/8" - 2"1/2" - 2"5/8" - 2"3/4" - 2"7/8" - 3"
3525	3525...	1"1/2" - 1"5/8" - 1"3/4" - 1"7/8" - 2" - 2"1/8" - 2"1/4" - 2"3/8" - 2"1/2" - 2"5/8" - 2"3/4" - 2"7/8" - 3" - 3"1/8" - 3"1/4" - 3"3/8" - 3"1/2"
3535	3535...	1"1/2" - 1"5/8" - 1"3/4" - 1"7/8" - 2" - 2"1/8" - 2"1/4" - 2"3/8" - 2"1/2" - 2"5/8" - 2"3/4" - 2"7/8" - 3" - 3"1/8" - 3"1/4" - 3"3/8" - 3"1/2"
4030	4030...	1"3/4" - 1"7/8" - 2" - 2"1/8" - 2"1/4" - 2"3/8" - 2"1/2" - 2"5/8" - 2"3/4" - 2"7/8" - 3" - 3"1/8" - 3"1/4" - 3"3/8" - 3"1/2" - 3"3/4" - 4"
4040	4040...	1"3/4" - 1"7/8" - 2" - 2"1/8" - 2"1/4" - 2"3/8" - 2"1/2" - 2"5/8" - 2"3/4" - 2"7/8" - 3" - 3"1/8" - 3"1/4" - 3"3/8" - 3"1/2" - 3"3/4" - 4"
4535	4535...	2"1/4" - 2"3/8" - 2"1/2" - 2"5/8" - 2"3/4" - 2"7/8" - 3" - 3"1/8" - 3"1/4" - 3"3/8" - 3"1/2" - 3"3/4" - 4" - 4"1/4" - 4"1/2"
4545	4545...	2"1/4" - 2"3/8" - 2"1/2" - 2"5/8" - 2"3/4" - 2"7/8" - 3" - 3"1/8" - 3"1/4" - 3"3/8" - 3"1/2" - 3"3/4" - 4" - 4"1/4" - 4"1/2"
5040	5040...	2"3/4" - 2"7/8" - 3" - 3"1/8" - 3"1/4" - 3"3/8" - 3"1/2" - 3"3/4" - 4" - 4"1/4" - 4"1/2" - 4"3/4" - 5"
5050	5050...	2"3/4" - 2"7/8" - 3" - 3"1/8" - 3"1/4" - 3"3/8" - 3"1/2" - 3"3/4" - 4" - 4"1/4" - 4"1/2" - 4"3/4" - 5"

Dimensioni delle cave (B.S. 46: part. 1: 1958) con fori in pollici

Dimensions of keyways (B.S. 46: part. 1: 1958) with standard bores in inches

Abmessungen der Keilnuten (B.S. 46: part. 1: 1958) mit Standardbohrung in Zoll

Dimensions des rainures des clavettes (B.S. 46: part. 1: 1958) dans le moyeux avec alésage standard série en pouces

Medidas de los chaveteros (B.S. 46: part. 1: 1958) en los casquillos con taladro standard en pulgadas

D		b	t		Dimensioni delle cave ribassate Dimensions of low profile keyways Abmessungen der abgeflachten Keilnuten Dimensions des rainures de clavette surbaissées Medidas de los chaveteros rebajados		
OVER	TO				D*	b	t
1/4"	1/2"	1/8"	D + 1/16"		1"*	1/4"	D + 1/16"
1/2"	3/4"	3/16"	D + 3/32"		1"1/8 *	5/16"	D + 5/64"
3/4"	1"	1/4"	D + 1/8"		1"5/8 *	7/16"	D + 1/8"
1"	1"1/4"	5/16"	D + 1/8"				
1"1/4"	1"1/2"	3/8"	D + 1/8"				
1"1/2"	1"3/4"	7/16"	D + 5/32"				
1"3/4"	2"	1/2"	D + 5/32"				
2"	2"1/2"	5/8"	D + 7/32"				
2"1/2"	3"	3/4"	D + 1/4"				
3"	3"1/2"	7/8"	D + 5/16"				
3"1/2"	4"	1"	D + 3/8"				
4"	5"	1"1/4"	D + 7/16"				
5"	6"	1"1/2"	D + 1/2"				
6"	7"	1"3/4"	D + 5/8"				

SCHIZZO PER PULEGGE DENTATE A DISEGNO DESIGN SKETCH FOR CUSTOM MADE TIMING PULLEYS

Puleggia senza mozzo e flange - Tipo (D)
Pulley without hub and flanges - Type (D)

Larghezza totale = Fascia dentata
Total width = Toothed width

Diametro foro
Bore diameter

Scegliere / Choose
Cava per chiave / Keyway
 Sì / Yes No / No

Tipo / Type

Scegliere / Choose
Flangia piatta
Flat flange
Flangia piegata
Folding flange

Larghezza cinghia
Belly Width

Materiale / Material
Trattamento / Treatment
N° denti / Teeth nr
Profilo e passo / Profile and pitch

Note / Notes

Riferimento n° / Reference nr

Puleggia senza mozzo con flange - Tipo (C)
Pulley with flanges, no hub - Type (C)

Larghezza totale = Fascia dentata
Total width = Toothed width

Diametro foro
Bore diameter

Scegliere / Choose
Cava per chiave / Keyway
 Sì / Yes No / No

Tipo / Type

Scegliere / Choose
Flangia piatta
Flat flange
Flangia piegata
Folding flange

Larghezza cinghia
Belly Width

Materiale / Material
Trattamento / Treatment
N° denti / Teeth nr
Profilo e passo / Profile and pitch
Codice flangia / Flange code

Note / Notes

Riferimento n° / Reference nr

The data and information contained in the present catalogue are up-to-dated to the date of the catalogue's printing. Megadyne Spa reserves the right to modify the specifications, performances and other information relating to the belts described in the present catalogue, at any time at its own discretion, without any prior notice. For updating refer to our web site www.megadynegroup.com.

Technical specifications, performances and other information provided in the present catalogue are indicative and do not bound Megadyne unless such specifications, performances or other information are expressly agreed in the agreement with the customer.

We also recommend to read carefully the following documents in our web site www.megadynegroup.com:

- Megadyne General Conditions of Sale (comprising the warranty) - Theoretical Belt Life
- Drive Components: Storage, Installation, Maintenance and Troubleshooting Handbook
- Belts standard use condition and temperature.

Copyright Notice: Megadyne Spa copyright. All rights reserved. Megadyne is and shall remain the owner of all rights on drawings, technical specifications and any other information contained in the present catalogue or otherwise communicated by Megadyne Spa to the customer. The customer shall not disclose such information to third parties or use such information for purposes different from the definition of the order to Megadyne Spa, unless upon prior written authorization of Megadyne.



S.A.T.I. S.p.A.
Con Unico Socio



S.A.T.I. S.p.A.
Con Unico Socio



S.A.T.I. S.p.A.
Con Unico Socio

AUSTRALIA**Victoria**

Phone +61 (03) 9763 6701
 au-ptsales@ammega.com

BRASIL**Sorocaba**

Phone +55 15 2101 7700
 Info.br@megadynegroup.com

CANADA**Edmonton**

Phone +1 780 461 4400
 Info.ca@megadynegroup.com

Montreal

Phone +1 514 695 1313
 Info.ca@megadynegroup.com

Toronto

Phone +1 905 602 4400
 Info.ca@megadynegroup.com

CHINA**Beijing**

Phone +86 10 8150 7478
 info.cn@megadynegroup.com

Foshan

Phone +86 757 8381 5530
 info.cn@megadynegroup.com

Ningbo*

Phone +86 574 8650 5008
 info.cn@megadynegroup.com

Phone +86 574 8833 4378
 sales@challengept.com

Qingdao*

Phone +86 532 8658 0951
 info.cn@megadynegroup.com

Shanghai

Phone +86 21 5447 1473
 info.cn@megadynegroup.com

Xi'an

Phone +86 29 86358108
 info.cn@megadynegroup.com

COLOMBIA**Bogotá**

Phone + 57 1 390 4325
 Info.co@megadynegroup.com

Cartagena

Phone + 57 5 693 2591
 Info.co@megadynegroup.com

Mosquera – Cundinamarca

Phone +57 1 893 9890
 info.co@megadynegroup.com

CZECH REPUBLIC**Prague**

Phone +420 603 461 892
 Info.cz@megadynegroup.com

FRANCE**Paris**

Phone +33 1 6079 8200
 info.fr@megadynegroup.com

GERMANY**Borchen**

Phone +49 5251 8735 0
 info.de@megadynegroup.com

HUNGARY**Budapest**

Phone +36 23 428 628
 info.hu@megadynegroup.com

INDIA**Chennai***

Phone +91 98841 81175
 info.in@megadynegroup.com

IRELAND**Dublin**

Phone +353 1 456 6311
 ireland@challengept.com

ISRAEL**Caesarea**

Phone +972 4 637 1485
 info.il@megadynegroup.com

ITALY**Turin***

Phone +39 011 926 8052
 info@megadynegroup.com

Bologna

Phone +39 051 672 16 11
 info@satispa.com

Pescara*

Phone +39 085 9700547
 info.it@megadynegroup.com

Venice

Phone +39 041 929 367
 info.it@megadynegroup.com

JAPAN**Nagoya**

Phone +81 52 433 7400
 info.jp@megadynegroup.com

MEXICO**Mexico C.P.**

Phone +52 55 5587 3680
 info.mx@megadynegroup.com

PERU**Lima**

Phone + 51 1 713 0069
 info.pe@megadynegroup.com

POLAND**Bielsko Biala**

Phone + 48 32 447 7179
 info.pl@megadynegroup.com

Bydgoszcz*

info.pl@megadynegroup.com

SINGAPORE**Singapore**

Phone +65 62739767
 Info.sg@megadynegroup.com

SOUTH AFRICA**Johannesburg**

Phone + 27 (0) 12 661 1652
 info.za@megadynegroup.com

Phone + 27 (0) 11 3976115
 sasales@challengept.com

Cape Town

Phone +27 (0)21 9820772
 info.za@megadynegroup.com

SOUTH KOREA**Gyeonggi-do**

Phone +82 314483613-7
 Info.kr@megadynegroup.com

SPAIN**Vilanova***

Phone +34 93 811 5450
 info.es@megadynegroup.com

SWEDEN**Kristianstad**

Phone +46 10 1309600
 info.se@megadynegroup.com

THAILAND**Bangkok**

Phone +66 2 902260413
 info.th@megadynegroup.com

TURKEY**Izmir**

Phone +90 232 877 07 00
 info.tr@megadynegroup.com

U.K.**Birmingham**

Phone +44 1384 215 021
 info.uk@megadynegroup.com

Wolverhampton

Phone +44 (0) 1902 866116
 uksales@challengept.com

U.S.A**California**

Phone +1 323 265 8061
 info.us@megadynegroup.com

Florida

Phone +1 813 241 4111
 info.us@megadynegroup.com

Georgia*

info.us@megadynegroup.com

Illinois

Phone +1 630 752 0600
 info.us@megadynegroup.com

New Jersey Americas HQ

Phone +1 973 227 4904
 info.us@megadynegroup.com

North Carolina*

info.us@megadynegroup.com

Oregon

Phone +1 503 231 7224
 info.us@megadynegroup.com

Texas

Phone +1 972 438 6992
 info.us@megadynegroup.com

*** Manufacturing locations****GENERAL CONTACT INFORMATION****MEGADYNE**

Via S. Lucia, 114
 10075 Mathi (Torino)

Phone +39 011 926 8052
 info@megadynegroup.com

ammega.com