

**PV-BELTS**



**MEGADYNE**

MEGADYNE PV-belts	<b>2</b>
Belt features and structure	<b>3</b>
Belt cross sections and dimensions	<b>4</b>
Pulleys	<b>5</b>
Standard belt range	<b>6</b>
Symbols, units, terms	<b>8</b>
Drive calculation procedure	<b>9</b>
Table 8: performance parameters PH - rubber	<b>14</b>
Table 9: performance parameters PJ - rubber	<b>16</b>
Table 10: performance parameters PK	<b>18</b>
Table 11: performance parameters PL	<b>20</b>
Table 12: performance parameters PM	<b>22</b>
Table 13: performance parameters PH - polyurethane	<b>24</b>
Table 14: performance parameters PTB2	<b>26</b>
Table 15: performance parameters PJ - polyurethane	<b>28</b>
Drive installation instructions	<b>30</b>
Poly-V elastic belts	<b>32</b>
Table: length tolerances	<b>34</b>
Useful formulas	<b>35</b>

## MEGADYNE PV-BELTS

MEGADYNE PV belts have been used for decades in the most different industries and applications, giving drive solutions to customers all over the world. Based on our experience, MEGADYNE PV belts have followed continuous development to meet the requirements of the market.

On the following pages you will find all the information to analyse and design a durable and smooth running PV belt drive.

For applications with special requirements please do not hesitate to contact our OEM TEAM in order to receive direct support to find the best solution.

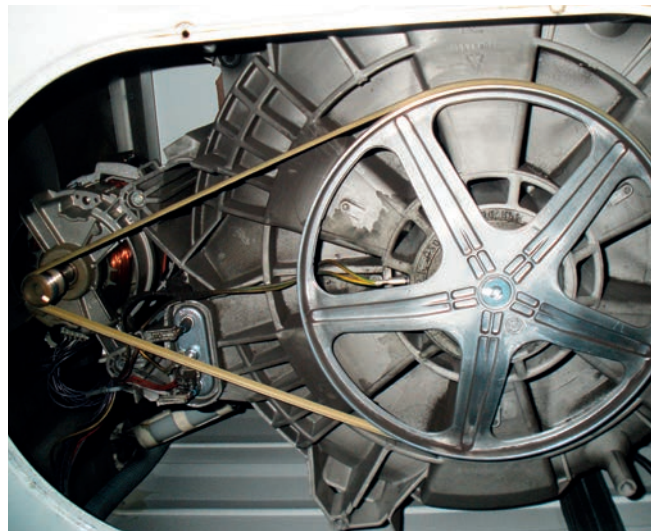
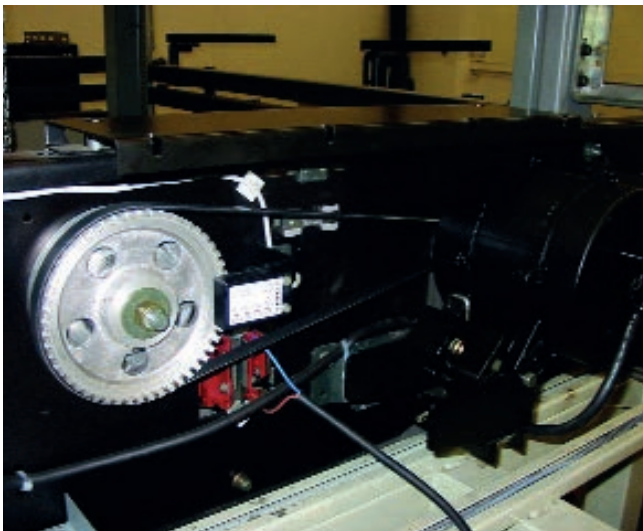
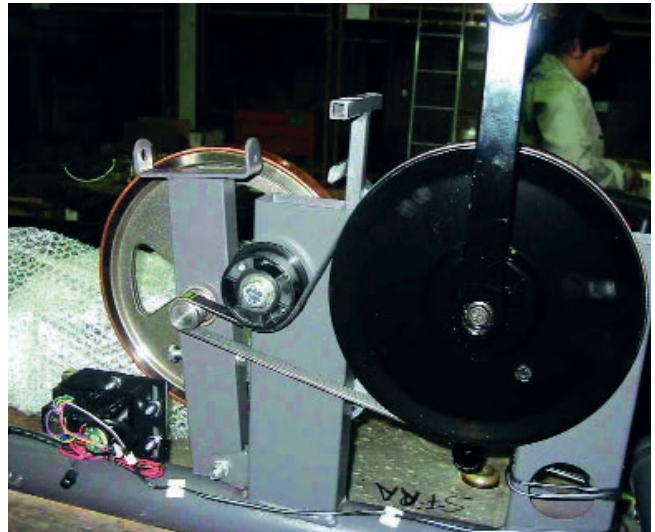
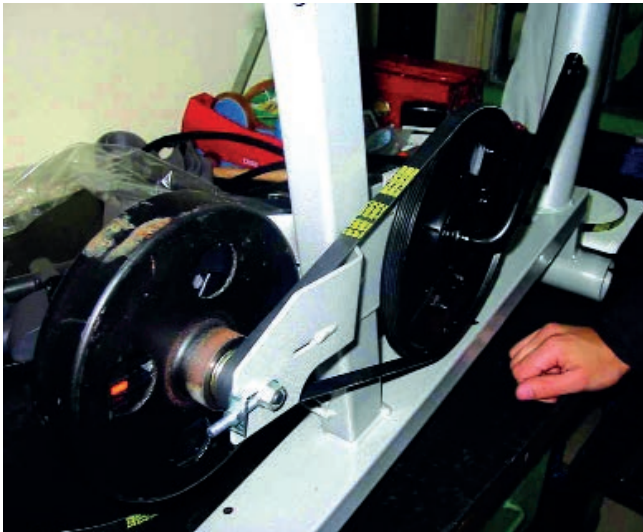

# BELT FEATURES AND STRUCTURE

MEGADYNE V-ribbed belts are endless rubber or polyurethane belts with longitudinal V shaped grooves. They transmit the motor power by friction from the driver to the driven side of the machine.

PV belts provide high flexibility and great power performance as they combine the benefits of flat and V belts.

Due to the use of high quality components and the variety of belt cross sections, Megadyne PV belts can be used in a wide variety of drive applications.

## ADVANTAGES OF PV BELTS

- Even distribution of the working load throughout the complete belt width.
- Compact smooth running drive system with low vibration.
- Small pulley diameters can be used in combination with inside or outside idlers.
- Linear belt speeds up to 60 [m/s] are possible.
- High transmission ratio.
- Flat pulleys can be used in order to reduce drive costs.
- Difficult drive configurations, such as serpentine or twisted drives, can be designed due to the high flexibility of MEGADYNE PV belts.
- Resistance to temperatures from -30 to +80 [°C] for rubber PV and from -15 to +60 [°C] for polyurethane PV.
- Power performance can be improved by increasing the number of ribs.
- Rubber PV have antistatic properties according to ISO 1813.
- Manufactured according to ISO 9982.
- PV-belts are also available in elastic version (TEM) for applications with fixed centre distance.

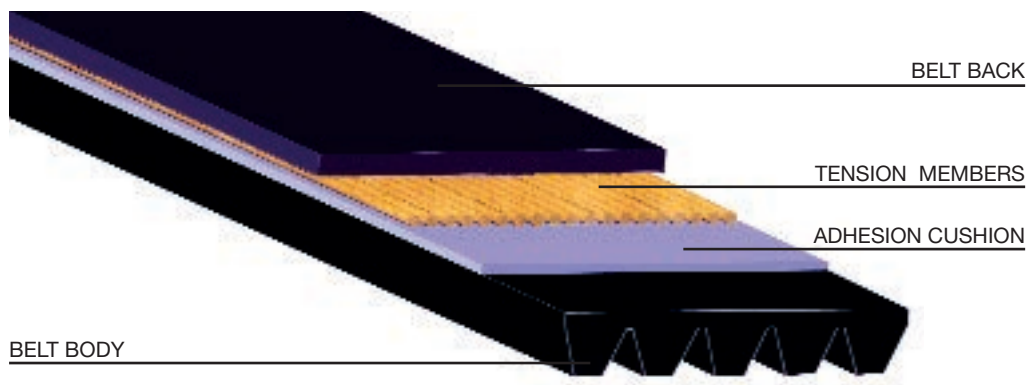

### a) BELT BODY

Rubber: special polybutadiene-based rubber compound.

Polyurethane: thermoset polyurethane with a  $85 \pm 5$  ShA hardness.

### b) TENSILE MEMBER

The tensile member consists of high-strength low-stretch polyester cords, which grant length stability over the belt life time.

### c) BELT BACK

The back side cushion protects the tensile member and permits the use of backside idlers.

# BELT CROSS SECTIONS AND DIMENSIONS

PV belts are divided in six different profiles to cover the needs of a wide range of applications. The dimensions and properties of each profile, are summarised in the following table:



**D<sub>p</sub>**: The pitch diameter is used to calculate the transmission ratio and the belt speed.

**D<sub>eff</sub>**: For grooved pulleys, the effective diameter is equal to the outside diameter.

**D<sub>out</sub>**: Depending if the pulley is flat or grooved the value h or hr have to be added in order to calculate the pitch diameter of the pulleys.

	MATERIAL	PU-RUBBER	PU	PU-RUBBER	RUBBER		
		PH	PTB2	PJ	PK	PL	PM
Belt dimensions	Sg [mm]	1.6	2.0	2.34	3.56	4.70	9.40
	Hb [mm]	2.6	2.2	3.5	4.6	6.6	12.8
	h [mm]	0.8	0.6	1.2	2.0	3.0	4.0
	hr [mm]	1.2	1.3	1.7	2.5	4.75	6.3
Drive parameters	Max. belt speed [m/s]	60	60	55	55	50	40
	Weight per rib [kg/m]	PU: 0.0036	0.0037	PU: 0.0073	0.0177	0.0354	0.1171
		RUBB: 0.0045		RUBB: 0.0085			
	Min. pulley diameter [mm]	13	15	20	45	75	180
	Min. diameter for external flat idlers [mm]	40	40	50	65	150	300
Min. diameter for internal flat idlers [mm]	22	30	38	52	76	180	

TABLE 1. Basic design data

For further information regarding belt dimensions, please consult ISO 9982.

Application examples			
PH	Household appliances	Dryers	Washing machines
PTB2	Slicers	Balancing machines	
PJ	Magnetic agitators Automatic doors Concrete mixers	Fitness equipments Floor polishers Elevator doors	Laundry machines Small compressors Lift appliances, etc..
PK	Tractors Lifting equipment	Elevators Fans	Pumps & compressors Wood saws, etc...
PL	High pressure cleaners Piston compressors	Flour mills Escalators	Crushers Brick machinery, etc...
PM	Paper industry Quarries	Hammer mills Granulators	Turbines Excavators, etc...

TABLE 2. Application examples of PV Belts

To provide the best working conditions, it is recommended to use steel, cast iron or anodised aluminium pulleys. The use of other materials will reduce the transmission efficiency due to loss of friction. All pulleys should be manufactured according to ISO 9982 with a surface finish of at least  $Ra = 3.2 \text{ } [\mu\text{m}]$  and have to be dynamically balanced.

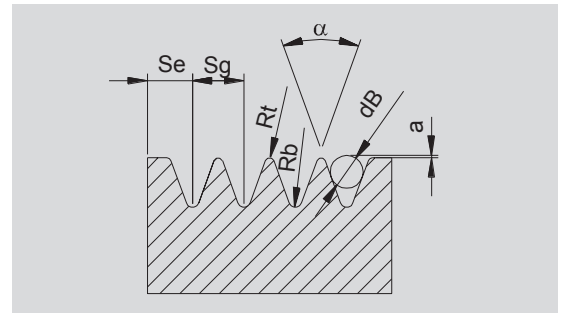

	PH	TB2	PJ	PK	PL	PM
$\alpha$ [°]	$40 \pm 0.5$	$60 \pm 0.5$	$40 \pm 0.5$	$40 \pm 0.5$	$40 \pm 0.5$	$40 \pm 0.5$
Sg [mm]	$1.6 \pm 0.03$	$2.0 \pm 0.03$	$2.34 \pm 0.03$	$3.56 \pm 0.05$	$4.7 \pm 0.05$	$9.4 \pm 0.08$
Se [mm]	1.3	1.3	1.8	2.5	3.3	6.4
dB [mm]	$1 \pm 0.01$	$1 \pm 0.01$	$1.5 \pm 0.01$	$2.5 \pm 0.01$	$3.5 \pm 0.01$	$7 \pm 0.01$
2a [mm]	0.11	0.07	0.23	0.99	2.36	4.53
$R_{t, \min}$ [mm]	0.15	0.30	0.2	0.25	0.4	0.75
$R_{b, \max}$ [mm]	0.3	0.15	0.4	0.5	0.4	0.75

TABLE 3: Basic pulley data

## IDLERS

Idlers simplify the assembly and disassembly of belts. They have to be used on the slack side of the transmission and may be installed in the inside or the outside part of the drive. In order to keep the wrapping angle on the small pulley as big as possible, we recommend to position them as follows:

Inside idlers => Idler position closer to the bigger pulley!  
 Outside idler => Idler position closer to the smaller pulley!

Idler diameters should always be chosen as big as possible and should never be smaller than indicated in TABLE 1.

Idlers can be made of steel or plastic while its smooth surface finish should respect a quality of at least  $Ra = 3.2 \text{ } [\mu\text{m}]$  and the radial run out should respect the indicated tolerance in TABLE 4.

Effective diameter [mm]	Maximum radial run out [mm]
$d_{\text{eff}} < 74$	0.13
$74 < d_{\text{eff}} < 250$	0.25
$d_{\text{eff}} > 250$	$0.25 + (d_{\text{eff}} - 250) / 2500$

TABLE 4: Radial run out tolerances

To assure that the belt runs with its complete width on the idler, we suggest to include the following recommendations in the idler design:

Belt width [n° of ribs]	Minimum idler width [mm]
$z < 10$	$(n^\circ \text{ ribs} + 2) \cdot Sg$
$z \geq 10$	$(n^\circ \text{ ribs} + 4) \cdot Sg$

TABLE 5: Minimum idler width

# STANDARD BELT RANGE

## MEGADYNE RUBBER PV BELT RANGE

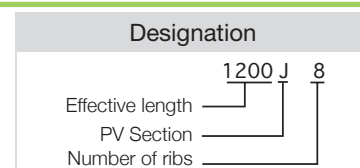

PJ		PJ		PK		PL		Effective length		PH	
Effective length		Effective length		Effective length		Effective 0		(mm) (inches)		Effective length	
(mm)	(inches)	(mm)	(inches)	(mm)	(inches)	(mm)	(inches)	(mm)	(inches)	(mm)	(inches)
350	13.8	1210	47.6	588	23.1	953	37.5	3493	137.0	584	23.0
381	15.0	1214	47.8	630	24.8	991	39.0	3696	145.5	947	37.3
406	16.0	1222	48.1	650	25.6	1041	41.0	4051	159.5	1025	40.4
432	17.0	1232	48.5	675	26.6	1074	42.3	4191	165.0	1030	40.6
457	18.0	1236	48.7	700	27.6	1080	42.5	4470	176.0	1068	42.0
483	19.0	1244	49.0	730	28.7	1100	43.3	4623	182.0	1140	44.9
495	19.5	1262	49.7	755	29.7	1150	45.3	5029	198.0	1164	45.8
508	20.0	1270	50.0	775	30.5	1168	46.0			1184	46.6
533	21.0	1280	50.4	800	31.5	1194	47.0			1200	47.2
559	22.0	1287	50.7	830	32.7	1219	48.0			1210	47.6
584	23.0	1295	51.0	845	33.3	1270	50.0			1265	49.8
610	24.0	1301	51.0	870	34.3	1295	51.0			1809	71.2
635	25.0	1302	51.3	875	34.4	1321	52.0			1831	72.1
650	25.6	1315	51.8	885	34.8	1334	52.5			1856	73.1
660	26.0	1318	51.9	920	36.2	1372	54.0			1872	73.7
685	27.0	1321	52.0	925	36.4	1397	55.0			1891	74.4
711	28.0	1326	52.2	950	37.4	1422	56.0			1900	74.8
723	28.5	1365	53.7	970	38.2	1435	56.5			1915	75.4
737	29.0	1371	54.0	1000	39.4	1473	58.0			1922	75.7
762	30.0	1397	55.0	1015	40.0	1498	59.0			1930	76.0
769	30.3	1428	56.2	1035	40.8	1511	59.5			1945	76.6
790	31.1	1473	58.0	1060	41.7	1562	61.5			1975	77.8
813	32.0	1524	60.0	1080	42.5	1613	63.5				
864	34.0	1549	61.0	1145	45.1	1651	65.0				
895	35.2	1600	63.0	1165	45.9	1664	65.5				
914	36.0	1651	65.0	1200	47.2	1715	67.5				
944	37.2	1752	69.0	1230	48.4	1765	69.5				
955	37.6	1854	73.0	1300	51.2	1803	71.0				
965	38.0	1895	74.6	1335	52.6	1842	72.5				
990	39.0	1910	75.2	1385	54.5	1943	76.5				
1016	40.0	1930	76.0	1420	55.9	1956	77.0				
1036	40.8	1956	77.0	1460	57.5	1981	78.0				
1040	40.9	2083	82.0	1490	58.7	2019	79.5				
1051	41.4	2135	84.1	1520	59.8	2070	81.5				
1065	41.9	2210	87.0	1555	61.2	2096	82.5				
1080	42.5	2337	92.0	1610	63.4	2134	84.0				
1089	42.9	2489	98.0	1655	65.2	2197	86.5				
1092	43.0			1700	66.9	2235	88.0				
1100	43.3			1725	67.9	2324	91.5				
1108	43.6			1755	69.1	2362	93.0				
1116	43.9			1800	70.9	2477	97.5				
1136	44.7			1860	73.2	2515	99.0				
1143	45.0			1885	74.2	2705	106.5				
1150	45.3			1900	74.8	2743	108.0				
1160	45.7			1980	78.0	2845	112.0				
1168	46.0			2050	80.7	2896	114.0				
1170	46.1			2080	81.9	2921	115.0				
1184	46.6			2145	84.5	2997	118.0				
1190	46.9			2235	88.0	3086	121.5				
1194	47.0			2330	91.7	3124	123.0				
1200	47.2			2490	98.03	3289	129.5				
1203	47.4			2555	100.59	3327	131.0				

PM	
Effective length	
(mm)	(inches)
2286	90,0
2388	94,0
2515	99,0
2693	106,0
2832	111,5
2921	115,0
3010	118,5
3124	123,0
3327	131,0
3531	139,0
3734	147,0
4089	161,0
4191	165,0
4470	176,0
4648	183,0
5029	198,0
5410	213,0
6121	241,0
6883	271,0
7646	301,0
8408	331,0
9169	361,0
9931	391,0
10693	421,0
12217	481,0
13741	541,0
15266	601,0
16764	660,0

TABLE 6a. Standard belt length

For measuring method and belt length tolerance please refer to ISO 9982.

## MEGADYNE POLYURETHANE PV BELT RANGE:

### Designation

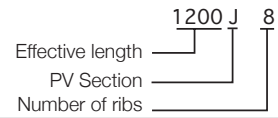

<b>PJ</b>	
Standard length (mm)	(inches)
220	8,7
271	10,7
275	10,8
278	10,9
283	11,1
288	11,3
304	12,0
317,5	12,5
330	13,0
345	13,6
356	14,0
381	15,0
392	15,4
406	16,0
431	17,0
444	17,5
457	18,0
483	19,0
508	20,0
558	22,0
584	23,0
610	24,0
630	24,8
660	26,0
681	26,8
711	28,0
762	30,0
864	34,0
914	36,0
953	37,5
1010	39,8
1086	42,8
1120	44,1
1163	45,8
1202	47,3
1239	48,8
1268	49,9
1397	55,0

<b>PTB2</b>	
Standard length (mm)	(inches)
156	6,1
170	6,7
200	7,9
220	8,7
231	9,1
248	9,8
266	10,5
295	11,6
310	12,2
330	13,0
345	13,6
360	14,2
380	15,0
390	15,4
400	15,7
430	16,9
480	18,9
510	20,1
526	20,7
535	21,1
575	22,6
598	26,5
630	24,8
660	26,0
675	26,6
725	28,5
770	30,3
1186	46,7

<b>PH</b>	
Standard length (mm)	(inches)
223	8,8
261	10,3
269	10,6
295	11,6
330	13,0
340	13,4
345	13,6
375	14,8
389	15,3
507	19,9
588	23,1
609	24,0
650	25,6
768	30,2
935	36,8
1000	39,4
1086	42,8
1120	44,1
1163	45,8
1203	47,4
1240	48,8
1775	69,9

TABLE 6b. Standard belt length



## SYMBOLS, UNITS, TERMS

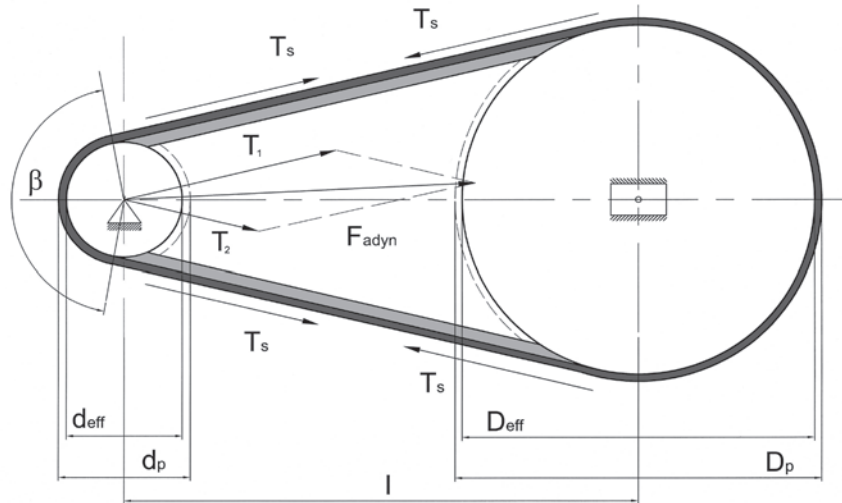

Symbol	Description	Unit
$\beta$	Arc of contact on the small pulley	[°]
$C_L$	Power correction factor for belt length	
$C_\beta$	Power correction factor for arc of contact	
$d_{eff}$	Effective diameter of small pulley	[mm]
$D_{eff}$	Effective diameter of large pulley	[mm]
$d_{out}$	Outside diameter of small pulley	[mm]
$D_{out}$	Outside diameter of large pulley	[mm]
$d_p$	Pitch diameter of small pulley	[mm]
$D_p$	Pitch diameter of large pulley	[mm]
$F_1$	Load on the first bearing	[N]
$F_2$	Load on the second bearing	[N]
$F_{adyn}$	Dynamic force	[N]
$F_s$	Service factor	
$F_{shaft, d}$	Dynamic shaft load	[N]
$i$	Speed ratio	
$l$	Centre distance	[mm]
$l_r$	Standard centre distance	[mm]
$L_1$	Bearing/ pulley distance	[mm]
$L_2$	Bearings distance	[mm]
$L$	Effective belt length	[mm]
$L_p$	Pitch belt length	[mm]
$L_r$	Belt standard length	[mm]
$m$	Belt mass weight per rib and meter	[kg/(m-rib)]
$n$	Revolutions on small pulley	[rpm]
$N$	Revolutions on large pulley	[rpm]
$P$	Motor power	[kW]
$P_a$	Additional power performance	[kW]
$P_b$	Basic power performance	[kW]
$P_c$	Design power	[kW]
$P_r$	Corrected power rating per rib	[kW]
$T_1$	Tight side tension	[N]
$T_2$	Slack side tension	[N]
$T_s$	Static belt tension of the span	[N/span]
$v$	Belt speed	[m/s]
$w$	Belt width	[mm]
$z$	Number of ribs	

# DRIVE CALCULATION PROCEDURE

## DESIGN CRITERIAS

To evaluate a drive and to select the correct PV belt cross section, the following parameters must be known:

1. Type or part of the machine where the belt will be installed.
2. Drive working conditions.
3. Type of motor and its nominal power.
4. Revolutions of the driver pulley.
5. Requested revolutions of the driven pulley.
6. Pulley dimension or required drive ratio.
7. Approximate centre distance.

Once all required data is known, follow the method as shown on the next pages. It explains the drive calculation procedure taking in consideration the parameters of an existing PV belt transmission.

## DRIVE PARAMETERS: (Parameters for the drive calculation example)

Application Working hours	Concrete mixer 10-16 hours/day
Motor Power Revolutions on driver shaft Motor class Small pulley diameter	P = 2 [kW] n = 6000 [rpm] Asynchronous (AC Motor) d <sub>out</sub> = 25 [mm]
Type of driven machine Absorbed power Revolutions on driven shaft Approx. Centre distance	Medium-high duty drive P <sub>absorb</sub> = 2 [kW] N = 900 [rpm] l = 134 [mm]

## DRIVE CALCULATION PROCEDURE:

COMMENT	DATA/ FORMULA	RESULT
STEP 1. Determine the design power		
Step 1a. Select service factor	See TABLE 5. Category 4; Motor Class A; 8 - 16 hours daily	F <sub>s</sub> = 1.4
Step 1b. Design power	$P_c < P < F_s$  P = 2 [kW] F <sub>s</sub> = 1,4	P <sub>c</sub> = 2.8 [kW]
STEP 2. Choose the belt cross section		
Step 2a. Select PV - Section	See GRAPHIC 1. P <sub>c</sub> = 2.8 [kW] n = 6000 [rpm]	Suggestion: PJ rubber profile

# DRIVE CALCULATION PROCEDURE

	SERVICE FACTOR					
	CLASS A			CLASS B		
	<ul style="list-style-type: none"> <li>AC Motor: Asynchronous,</li> <li>Synchronous, Normal Torque DC</li> <li>Motor: Shunt wound</li> <li>Internal combustion engines: Multicylinders speed &gt; 700 rpm</li> </ul>			<ul style="list-style-type: none"> <li>AC Motor: Vector control,</li> <li>Reluctance Motor, High Torque</li> <li>DC Motor: Compound wound</li> <li>Internal combustion engines: Turbines speed &lt; 700 rpm</li> </ul>		
	Duty cycle category					
	Intermittent service	Normal service	Continuous service	Intermittent service	Normal service	Continuous service
	< 8 hours daily	8 to 16 hours	> 16 hours daily	< 8 hours daily	8 to 16 hours	> 16 hours daily
Category 1: LIGHT DUTY DRIVES Blowers, Vacuum cleaners, Magnetic agitators, Domestic gadgets, Fans and pumps up to 7,5 kW	1,0	1,1	1,2	1,1	1,2	1,3
Category 2: MEDIUM DUTY DRIVES Machine tools, Generators, Rotary pumps, Belt conveyors, Laundry machinery	1,1	1,2	1,3	1,2	1,3	1,4
Category 3: MEDIUM-HIGH DUTY DRIVES Concrete and Woodwork machinery, Axial fans, Brick machinery	1,2	1,3	1,4	1,3	1,4	1,5
Category 4: HIGH DUTY DRIVES Hammer mills, Elevators, Paper machinery, Piston pumps, Dredging pumps, Granulators	1,3	1,4	1,5	1,4	1,5	1,6
Category 5: EXTRA DUTY DRIVES Excavators, Mixers, Ballgrinding mills, Winches	1,4	1,5	1,6	1,5	1,6	1,8

TABLE 7. Determination of the Service Factor

## GRAPHIC DESIGN POWER vs. RPM

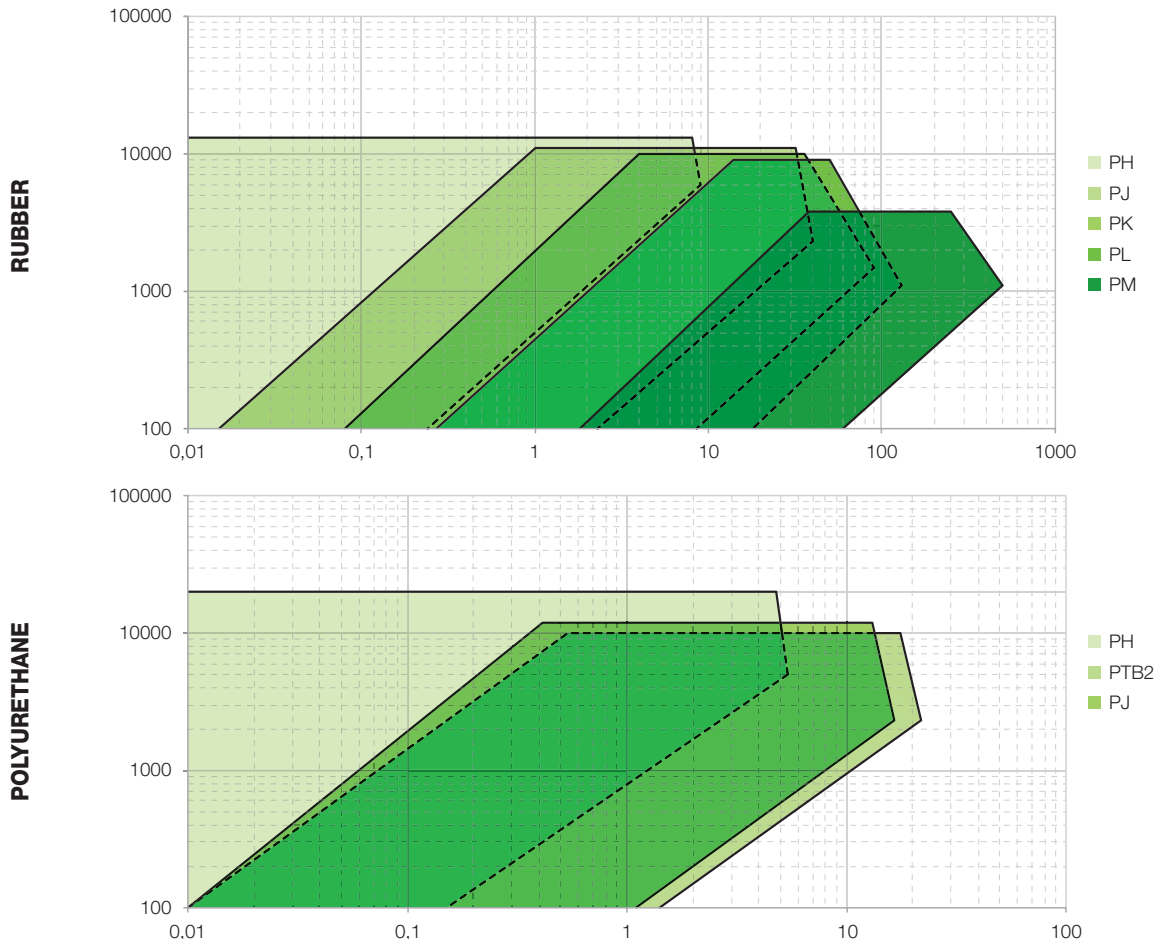

# DRIVE CALCULATION PROCEDURE

COMMENT	DATA/ FORMULA	RESULT
<b>STEP 3. Calculate speed ratio and effective diameters.</b>		
Step 3a. Determine the speed ratio.	$i = \frac{n}{N}$ $n = 6000 \text{ [mm]}$ $N = 900 \text{ [mm]}$	$i = 6.7$
Step 3b. Determine the small pulley pitch diameter.	$d_p = d_{out} + 2 \cdot h$ See TABLE 1: $d_{out} = 25 \text{ [mm]}$ $F_s = 1,4$	$d_p = 27.4 \text{ [mm]}$
Step 3c. Calculate the large pulley pitch diameter.	$D_p = d_p \cdot i$ $d_p = 27.4 \text{ [mm]}$ $i = 6.7$	$D_p = 183.5 \text{ [mm]}$
Step 3d. Calculate the large pulley outside diameter.	In this case Grooved pulley!! $D_{out} = D_p - 2 \cdot h$ $D_p = 183.5 \text{ [mm]}$ $h = 1.2 \text{ [mm]}$ If flat pulley, use: $D_{out} = D_p - 2 \cdot (h + h_r)$	$D_{out} = 181.1 \text{ [mm]}$
<b>STEP 4. Calculate the linear speed of the belt.</b>		
Step 4a. Calculate the linear speed.	$v = \frac{\pi \cdot d_p \cdot n}{60000}$ $n = 6000 \text{ [rpm]}$ $d_p = 27.4 \text{ [mm]}$	$v = 8.61 \text{ [m/s]}$
Step 4b. Check if the result matches the requirements.	Compare the resulting linear speed to the one defined for each profile.  See TABLE 1.	$v = 8.61 \text{ [m/s]} < 50 \text{ [m/s]}$ Belt section PJ is suitable.
<b>STEP 5. Calculate the effective belt length and the centre distance.</b>		
Step 5a. Calculate the belt pitch length.	$L_p = 2l + 1.57 \cdot (D_p + d_p) + \frac{(D_p - d_p)^2}{4l}$ $D_p = 183.5 \text{ [mm]}$ $d_p = 27.4 \text{ [mm]}$ $l = 134 \text{ [mm]}$	$L_p = 644.5 \text{ [mm]}$
Step 5b. Calculate the effective belt length.	$L = L_p - 2 \cdot h \cdot \pi$ $L_p = 644.5 \text{ [mm]}$ $h = 1.2 \text{ [mm]}$	$L = 637 \text{ [mm]}$
Step 5c. Select a standard belt length from TABLE 6a.	Select a standard belt length as close as possible to $L = 637 \text{ [mm]}$ .  NOTE: If the calculated belt length does not correspond to any standard belt length, choose the next longer one.	$L_r = 650 \text{ [mm]}$
Step 5d. Recalculate the real centre distance by applying the standard belt length deviation.	$l_r = l + \frac{\Delta L}{2} = l + \frac{L_r - L}{2}$ $L_r = 650 \text{ [mm]}$ $L = 637 \text{ [mm]}$ $l = 134 \text{ [mm]}$	$l_r = 140.5 \text{ [mm]}$

# DRIVE CALCULATION PROCEDURE

COMMENT	DATA/ FORMULA	RESULT
<b>STEP 6. Determine the number of ribs.</b> (To carry on with the calculation please go to the pages defining the chosen belt cross section)		
Step 6a. Determine the arc of contact	$\beta = 180 - 57 \cdot \frac{D_p - d_p}{l_r}$ $D_p = 183.5 \text{ [mm]}$ $d_p = 27.4 \text{ [mm]}$ $l_r = 140.5 \text{ [mm]}$	$\beta = 116.7 \text{ [}^\circ\text{]}$
Step 6b. Determine $C_\beta$	Select $C_\beta$ according to the arc of contact. See TABLE 9	$C_\beta = 0.78$
Step 6c. Determine $C_L$	Select $C_\beta$ according to the standard belt length. See TABLE 9	$C_L = 0.84$
Step 6d. Determine $P_a$	Determine the additional power from TABLE 9	$P_a = 0.05 \text{ [kW]}$
Step 6e. Determine $P_b$	Determine the basic performance from TABLE 9	$P_b = 0.35 \text{ [kW]}$
Step 6f. Determine $P_r$	$P_r = (P_b + P_a) \cdot C_\beta \cdot C_L$	$P_r = 0.26 \text{ [kW]}$
Step 6g. Calculate number of ribs & determine the code of the calculated belt.	$z = P_c / P_r$ $P_c = 2.8 \text{ [kW]}$	$z = 12$ N. of ribs approximated to a standard grooved pulley. Belt code: 660 J 12
<b>STEP 7. Calculate the belt tension, the shaft load and the forces on the bearings.</b>		
Step 7a. Calculate the span pretension.	$T_s = \frac{500 \cdot (2.5 - C_\beta) \cdot P_c}{C_\beta \cdot v} + m \cdot z \cdot v^2$ From TABLE 1: $m = 0.0085 \text{ [kg/m/rib]}$ $C_\beta = 0.78$ $v = 8.61 \text{ [m/s]}$ $z = 12$ $P_c = 2.8 \text{ [kW]}$	$T_s = 366 \text{ [N/span]}$
Step 7b. Calculate the shaft load.	$F_{\text{shaft,d}} = \sqrt{\frac{T_e^2}{2} + 2 \cdot T_s^2 - 2 \cdot \cos \beta \cdot \left( T_s^2 - \frac{T_e^2}{4} \right)}$ $P = 2 \text{ [kW]}$ $\beta = 116.7 \text{ [}^\circ\text{]}$ $v = 8.61 \text{ [m/s]}$ $T_s = 366 \text{ [N]}$	$F_{\text{shaft,d}} = 634 \text{ [N]}$  Where: $T_e = 1000 \cdot P / v$
Step 7c. Calculate the bearing loads.	$F_1 = F_{\text{shaft,d}} \cdot \frac{(L_1 - L_2)}{L_2}$ $F_2 = F_{\text{shaft,d}} \cdot \frac{L_1}{L_2}$ $F_{\text{shaft,d}} = 634 \text{ [N]}$ $L_1 = 6 \text{ [mm]}$ $L_2 = 40 \text{ [mm]}$	$F_1 = 318 \text{ [N]}$  $F_2 = 953 \text{ [N]}$

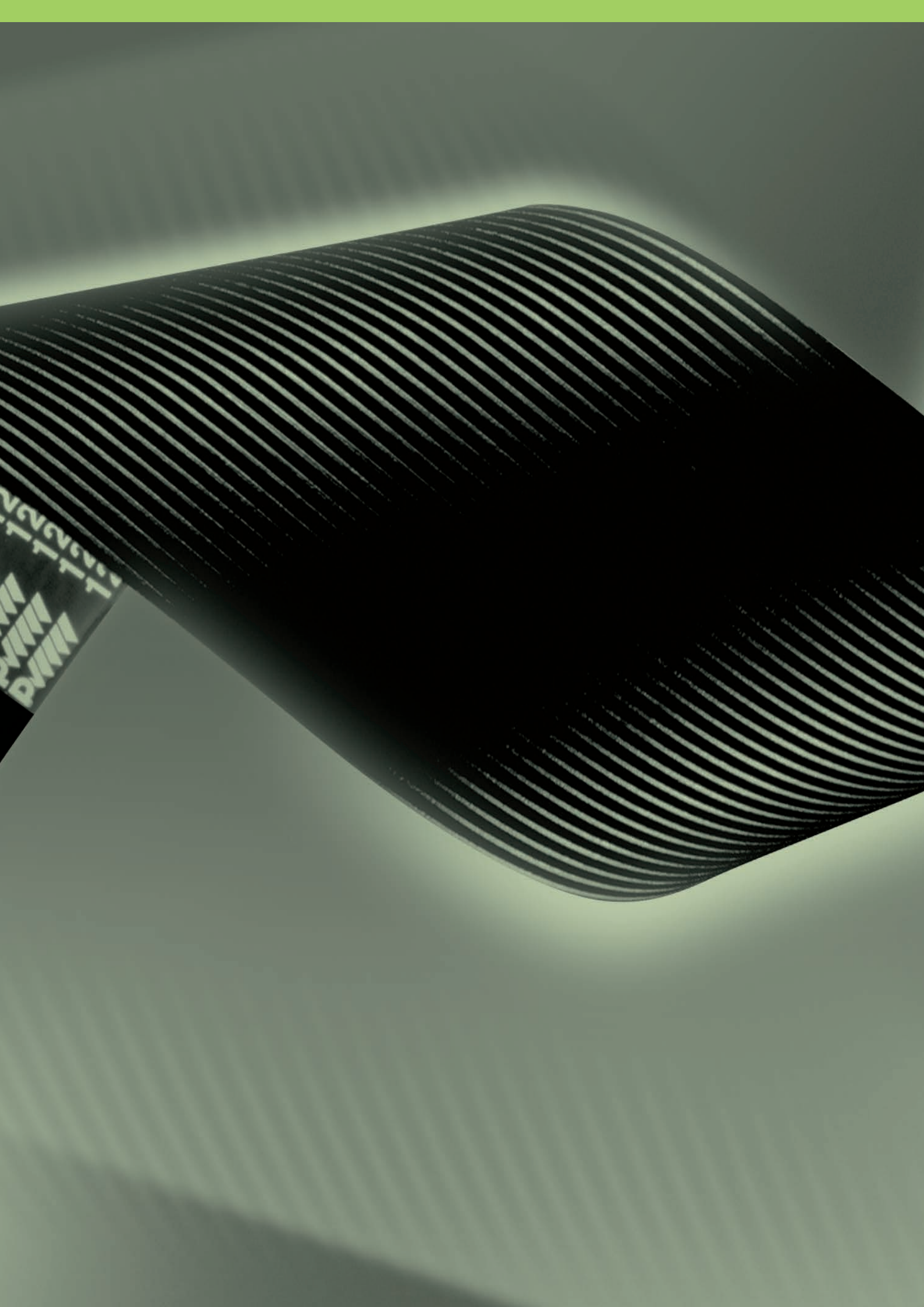

www.pwll.co.uk  
Tel: 01493 811111  
Pwll  
Pwll

**TABLE 8: PERFORMANCE PARAMETERS PH - RUBBER**

Length correction factor $C_L$	
Effective length [mm]	Correction factor
Up to 500	0,89
500 to 700	0,95
700 to 900	1,0
900 to 1100	1,05
1100 to 1300	1,07
1300 to 1500	1,12
1500 to 1700	1,15
1700 to 1900	1,17
1900 to 2100	1,19
Above 2100	1,20

Arc of contact correction factor $C_\beta$	
Arc of contact small pulley [°]	Correction factor
230	1,11
220	1,09
210	1,07
200	1,05
190	1,02
180	1,00
170	0,97
160	0,94
150	0,91
140	0,88
130	0,84
120	0,80
110	0,76
100	0,72
91	0,67
83	0,63

	Basic power [kW/ rib] for small pulley effective diameter [mm]																	
	$d_{eff}$	13	17	20	25	31,5	35,5	40	45	50	63	71	80	90	100	112	125	
SMALL PULLEY'S SPEED [rpm]	100				0,01	0,01	0,01	0,01	0,01	0,01	0,02	0,02	0,02	0,02	0,02	0,03	0,03	
	300	0,01	0,01	0,01	0,01	0,02	0,02	0,03	0,03	0,03	0,04	0,05	0,05	0,06	0,06	0,07	0,08	
	500	0,01	0,01	0,02	0,02	0,03	0,03	0,04	0,05	0,05	0,06	0,07	0,08	0,09	0,10	0,11	0,13	
	700	0,01	0,02	0,02	0,03	0,04	0,05	0,05	0,06	0,07	0,08	0,09	0,10	0,11	0,12	0,14	0,15	0,17
	900	0,01	0,02	0,03	0,04	0,05	0,06	0,07	0,08	0,08	0,10	0,11	0,12	0,14	0,15	0,17	0,19	0,21
	1000	0,02	0,02	0,03	0,04	0,06	0,06	0,07	0,08	0,09	0,12	0,13	0,15	0,17	0,19	0,21	0,23	
	1100	0,02	0,03	0,03	0,05	0,06	0,07	0,08	0,09	0,10	0,13	0,15	0,16	0,18	0,20	0,23	0,25	
	1200	0,02	0,03	0,04	0,05	0,06	0,07	0,09	0,10	0,11	0,14	0,16	0,18	0,20	0,22	0,25	0,27	
	1300	0,02	0,03	0,04	0,05	0,07	0,08	0,09	0,10	0,12	0,15	0,17	0,19	0,21	0,24	0,26	0,29	
	1400	0,02	0,03	0,04	0,06	0,07	0,08	0,10	0,11	0,12	0,16	0,18	0,20	0,23	0,25	0,28	0,31	
	1500	0,02	0,03	0,04	0,06	0,08	0,09	0,10	0,12	0,13	0,17	0,19	0,22	0,24	0,27	0,30	0,33	
	1600	0,02	0,04	0,05	0,06	0,08	0,10	0,11	0,12	0,14	0,18	0,20	0,23	0,26	0,28	0,32	0,35	
	1700	0,02	0,04	0,05	0,07	0,09	0,10	0,12	0,13	0,15	0,19	0,21	0,24	0,27	0,30	0,34	0,37	
	1800	0,02	0,04	0,05	0,07	0,09	0,11	0,12	0,14	0,15	0,20	0,22	0,25	0,28	0,32	0,35	0,39	
	1900	0,03	0,04	0,05	0,07	0,10	0,11	0,13	0,14	0,16	0,21	0,23	0,27	0,30	0,33	0,37	0,41	
	2000	0,03	0,04	0,05	0,07	0,10	0,12	0,13	0,15	0,17	0,22	0,25	0,28	0,31	0,35	0,39	0,43	
	2100	0,03	0,04	0,06	0,08	0,10	0,12	0,14	0,16	0,18	0,23	0,26	0,29	0,33	0,36	0,40	0,45	
	2200	0,03	0,05	0,06	0,08	0,11	0,13	0,14	0,16	0,18	0,24	0,27	0,30	0,34	0,38	0,42	0,47	
	2300	0,03	0,05	0,06	0,08	0,11	0,13	0,15	0,17	0,19	0,25	0,28	0,31	0,35	0,39	0,44	0,49	
	2400	0,03	0,05	0,06	0,09	0,12	0,14	0,16	0,18	0,20	0,25	0,29	0,33	0,37	0,41	0,45	0,50	
	2500	0,03	0,05	0,07	0,09	0,12	0,14	0,16	0,18	0,21	0,26	0,30	0,34	0,38	0,42	0,47	0,52	
	2600	0,03	0,05	0,07	0,09	0,13	0,14	0,17	0,19	0,21	0,27	0,31	0,35	0,39	0,44	0,49	0,54	
	2700	0,03	0,05	0,07	0,10	0,13	0,15	0,17	0,20	0,22	0,28	0,32	0,36	0,41	0,45	0,50	0,56	
	2800	0,03	0,06	0,07	0,10	0,13	0,15	0,18	0,20	0,23	0,29	0,33	0,37	0,42	0,46	0,52	0,57	
	2900	0,03	0,06	0,07	0,10	0,14	0,16	0,18	0,21	0,23	0,30	0,34	0,38	0,43	0,48	0,53	0,59	
	3000	0,03	0,06	0,08	0,11	0,14	0,16	0,19	0,22	0,24	0,31	0,35	0,40	0,44	0,49	0,55	0,61	
	3100	0,04	0,06	0,08	0,11	0,15	0,17	0,19	0,22	0,25	0,32	0,36	0,41	0,46	0,51	0,56	0,62	
	3200	0,04	0,06	0,08	0,11	0,15	0,17	0,20	0,23	0,26	0,33	0,37	0,42	0,47	0,52	0,58	0,64	
	3300	0,04	0,06	0,08	0,11	0,15	0,18	0,20	0,23	0,26	0,34	0,38	0,43	0,48	0,53	0,59	0,66	
	3400	0,04	0,06	0,08	0,12	0,16	0,18	0,21	0,24	0,27	0,35	0,39	0,44	0,49	0,55	0,61	0,67	
	3500	0,04	0,07	0,09	0,12	0,16	0,19	0,21	0,25	0,28	0,35	0,40	0,45	0,51	0,56	0,62	0,69	
	3600	0,04	0,07	0,09	0,12	0,17	0,19	0,22	0,25	0,28	0,36	0,41	0,46	0,52	0,57	0,64	0,70	
	3700	0,04	0,07	0,09	0,13	0,17	0,20	0,23	0,26	0,29	0,37	0,42	0,47	0,53	0,59	0,65	0,72	
	3800	0,04	0,07	0,09	0,13	0,17	0,20	0,23	0,26	0,30	0,38	0,43	0,48	0,54	0,60	0,66	0,73	
	3900	0,04	0,07	0,09	0,13	0,18	0,20	0,24	0,27	0,30	0,39	0,44	0,49	0,55	0,61	0,68	0,75	
	4000	0,04	0,07	0,10	0,13	0,18	0,21	0,24	0,28	0,31	0,40	0,45	0,51	0,57	0,62	0,69	0,76	
4100	0,04	0,08	0,10	0,14	0,18	0,21	0,25	0,28	0,32	0,41	0,46	0,52	0,58	0,64	0,70	0,77		
4200	0,04	0,08	0,10	0,14	0,19	0,22	0,25	0,29	0,32	0,41	0,47	0,53	0,59	0,65	0,72	0,79		
4400	0,05	0,08	0,10	0,14	0,20	0,23	0,26	0,30	0,34	0,43	0,49	0,55	0,61	0,67	0,74	0,81		
4600	0,05	0,08	0,11	0,15	0,20	0,24	0,27	0,31	0,35	0,45	0,50	0,57	0,63	0,70	0,77	0,83		
4800	0,05	0,08	0,11	0,16	0,21	0,24	0,28	0,32	0,36	0,46	0,52	0,59	0,65	0,72	0,79	0,86		
5000	0,05	0,09	0,12	0,16	0,22	0,25	0,29	0,33	0,38	0,48	0,54	0,61	0,68	0,74	0,81	0,88		
5200	0,05	0,09	0,12	0,17	0,23	0,26	0,30	0,34	0,39	0,49	0,56	0,62	0,70	0,76	0,83	0,89		
5400	0,05	0,09	0,12	0,17	0,23	0,27	0,31	0,36	0,40	0,51	0,57	0,64	0,71	0,78	0,85	0,91		
5600	0,05	0,10	0,13	0,18	0,24	0,28	0,32	0,37	0,41	0,53	0,59	0,66	0,73	0,80	0,87	0,92		
5800	0,06	0,10	0,13	0,18	0,25	0,29	0,33	0,38	0,42	0,54	0,61	0,68	0,75	0,82	0,88	0,93		
6000	0,06	0,10	0,13	0,19	0,25	0,30	0,34	0,39	0,44	0,56	0,62	0,70	0,77	0,83	0,89	0,94		
6200	0,06	0,10	0,14	0,19	0,26	0,30	0,35	0,40	0,45	0,57	0,64	0,71	0,78	0,85	0,91	0,95		
6400	0,06	0,11	0,14	0,20	0,27	0,31	0,36	0,41	0,46	0,58	0,65	0,73	0,80	0,86	0,92	0,95		
6600	0,06	0,11	0,14	0,20	0,28	0,32	0,37	0,42	0,47	0,60	0,67	0,74	0,81	0,87	0,92	0,95		
6800	0,06	0,11	0,15	0,21	0,28	0,33	0,38	0,43	0,48	0,61	0,68	0,76	0,83	0,88	0,93	0,95		
7000	0,06	0,11	0,15	0,21	0,29	0,34	0,39	0,44	0,50	0,63	0,70	0,77	0,84	0,89	0,93	0,94		
7200	0,06	0,12	0,15	0,22	0,30	0,34	0,40	0,45	0,51	0,64	0,71	0,78	0,85	0,90	0,93	0,93		
7400	0,06	0,12	0,16	0,22	0,30	0,35	0,40	0,46	0,52	0,65	0,72	0,80	0,86	0,91	0,93	0,92		
7600	0,07	0,12	0,16	0,23	0,31	0,36	0,41	0,47	0,53	0,66	0,74	0,81	0,87	0,91	0,93	0,90		
7800	0,07	0,12	0,16	0,23	0,32	0,37	0,42	0,48	0,54	0,68	0,75	0,82	0,88	0,92	0,92	0,88		
8000	0,07	0,13	0,17	0,24	0,32	0,37	0,43	0,49	0,55	0,69	0,76	0,83	0,89	0,92	0,91	0,85		
8200	0,07	0,13	0,17	0,24	0,33	0,38	0,44	0,50	0,56	0,70	0,77	0,84	0,89	0,92	0,90	0,82		
8400	0,07	0,13	0,17	0,25	0,34	0,39	0,45	0,51	0,57	0,71	0,78	0,85	0,90	0,91	0,89	0,78		
8600	0,07	0,13	0,18	0,25	0,34	0,40	0,46	0,52	0,58	0,72	0,79	0,85	0,90	0,91	0,87	0,74		
8800	0,07	0,14	0,18	0,26	0,35	0,40	0,46	0,53	0,59	0,73	0,80	0,86	0,90	0,90	0,84	0,70		
9000	0,07	0,14	0,18	0,26	0,36	0,41	0,47	0,54	0,60	0,74	0,81	0,87	0,90	0,89	0,82	0,65		
9200	0,07	0,14	0,19	0,26	0,36	0,42	0,48	0,55	0,61	0,75	0,82	0,87	0,90	0,88	0,79			
9400	0,08	0,14	0,19	0,27	0,37	0,43	0,49	0,56	0,62	0,76	0,82	0,87	0,89	0,86	0,76			
9600	0,08	0,14	0,19	0,27	0,37	0,43	0,50	0,56	0,63	0,77	0,83	0,88	0,89	0,85	0,72			
9800	0,08	0,15	0,20	0,28	0,38	0,44	0,50	0,57	0,64	0,77	0,84	0,88	0,88	0,83	0,68			
10000	0,08	0,15	0,20	0,28	0,39	0,45	0,51	0,58	0,64	0,78	0,84	0,88	0,87	0,80	0,63			
10300	0,08	0,15	0,20	0,29	0,39	0,46	0,52	0,59	0,66	0,79	0,85	0,87	0,85	0,76				
10600	0,08	0,16	0,21	0,30	0,40	0,47	0,53	0,60	0,67	0,80	0,85	0,87	0,83	0,72				
10900	0,08	0,16	0,21	0,30	0,41	0,48	0,55	0,62	0,68	0,81	0,85	0,86	0,80	0,66				
11200	0,08	0,16	0,22	0,31	0,42	0,49	0,56	0,63	0,69	0,81	0,85	0,84	0,77</					

















# TABLE 12: PERFORMANCE PARAMETERS PM

Length correction factor $C_L$		Basic power [kW/ rib] for small pulley effective diameter [mm]															
Effective length [mm]	Correction factor	$d_{eff}$	180	190	200	212	224	250	280	315	355	400	450	500	560	630	710
Up to 2750	0,92	100	0,650	0,707	0,764	0,832	0,899	1,045	1,213	1,408	1,629	1,876	2,149	2,421	2,745	3,121	3,547
2750 to 3750	0,97	200	1,226	1,336	1,446	1,577	1,708	1,990	2,314	2,689	3,116	3,592	4,117	4,638	5,259	5,976	6,788
3750 to 5000	1,02	300	1,775	1,937	2,098	2,290	2,482	2,896	3,370	3,920	4,542	5,237	6,001	6,757	7,654	8,687	9,847
5000 to 7000	1,07	400	2,305	2,517	2,728	2,980	3,231	3,773	4,393	5,110	5,921	6,822	7,811	8,786	9,936	11,250	12,713
7000 to 9000	1,12	500	2,820	3,081	3,340	3,651	3,960	4,626	5,386	6,264	7,254	8,350	9,547	10,720	12,094	13,649	15,357
Above 9000	1,17	560	3,122	3,412	3,700	4,045	4,388	5,126	5,968	6,939	8,031	9,238	10,551	11,832	13,325	15,001	16,822
		600	3,321	3,630	3,937	4,304	4,669	5,455	6,351	7,381	8,540	9,817	11,203	12,551	14,115	15,861	17,743
		700	3,810	4,165	4,519	4,941	5,360	6,261	7,286	8,461	9,777	11,219	12,771	14,267	15,981	17,860	19,833
		720	3,906	4,270	4,633	5,066	5,496	6,420	7,469	8,673	10,018	11,490	13,073	14,595	16,334	18,232	20,212
		800	4,286	4,687	5,085	5,560	6,032	7,044	8,191	9,502	10,960	12,549	14,242	15,854	17,672	19,618	21,587
		900	4,750	5,195	5,637	6,163	6,685	7,802	9,065	10,500	12,087	13,801	15,607	17,300	19,171	21,107	22,962
		960	5,023	5,493	5,960	6,516	7,068	8,245	9,573	11,077	12,734	14,512	16,370	18,094	19,968	21,859	23,588
		1000	5,202	5,689	6,173	6,748	7,319	8,535	9,904	11,453	13,153	14,969	16,855	18,591	20,455	22,297	23,917
		1200	6,067	6,635	7,197	7,864	8,522	9,918	11,475	13,211	15,080	17,022	18,962	20,647	22,300		
		1400	6,879	7,519	8,152	8,900	9,635	11,182	12,884	14,747	16,701	18,651	20,476	21,904			
		1440	7,034	7,689	8,334	9,097	9,845	11,419	13,144	15,026	16,985	18,920	20,700	22,050			
		1600	7,632	8,338	9,032	9,848	10,647	12,311	14,112	16,035	17,975	19,793	21,311				
		1800	8,324	9,085	9,830	10,702	11,549	13,293	15,139	17,044	18,858	20,387					
		2000	8,947	9,754	10,539	11,452	12,331	14,113	15,943	17,743	19,307						
		2200	9,498	10,339	11,152	12,088	12,981	14,754	16,504	18,101							
		2400	9,970	10,833	11,660	12,602	13,489	15,202	16,798								
		2600	10,357	11,229	12,055	12,985	13,843	15,442	16,805								
		2800	10,655	11,521	12,330	13,225	14,032	15,456									
		2880	10,747	11,606	12,405	13,280	14,059	15,396									
		3000	10,856	11,701	12,477	13,315	14,044										
		3200	10,956	11,763	12,487	13,243	13,869										
		3400	10,947	11,699	12,352	13,001											
		3600	10,824	11,502	12,064												
		3800	10,581	11,165													
		4000	10,212														

**TABLE 12: PERFORMANCE PARAMETERS PM**

		Additional power [kW] according to speed ratio									
		1,00 1,01	1,02 1,04	1,05 1,08	1,09 1,12	1,13 1,18	1,19 1,24	1,25 1,34	1,35 1,51	1,52 1,99	2,00 >2,00
SMALL PULLEY'S SPEED [rpm]	100	0,00	0,01	0,01	0,02	0,03	0,03	0,04	0,05	0,05	0,06
	200	0,00	0,01	0,03	0,04	0,05	0,07	0,08	0,09	0,11	0,12
	300	0,00	0,02	0,04	0,06	0,08	0,10	0,12	0,14	0,16	0,18
	400	0,00	0,03	0,05	0,08	0,11	0,13	0,16	0,19	0,21	0,24
	500	0,00	0,03	0,06	0,10	0,13	0,16	0,20	0,23	0,27	0,30
	560	0,00	0,04	0,07	0,11	0,15	0,18	0,22	0,26	0,30	0,34
	600	0,00	0,04	0,08	0,12	0,16	0,20	0,24	0,28	0,32	0,36
	700	0,00	0,05	0,09	0,14	0,18	0,23	0,28	0,32	0,37	0,42
	720	0,00	0,05	0,09	0,14	0,19	0,23	0,29	0,33	0,38	0,43
	800	0,00	0,05	0,10	0,15	0,21	0,26	0,32	0,37	0,42	0,48
	900	0,00	0,06	0,11	0,17	0,24	0,29	0,36	0,42	0,48	0,54
	960	0,00	0,06	0,12	0,19	0,25	0,31	0,38	0,45	0,51	0,58
	1000	0,00	0,07	0,13	0,19	0,26	0,33	0,40	0,46	0,53	0,60
	1200	0,00	0,08	0,15	0,23	0,32	0,39	0,48	0,56	0,64	0,72
	1400	0,00	0,09	0,18	0,27	0,37	0,46	0,56	0,65	0,74	0,84
	1440	0,00	0,09	0,18	0,28	0,38	0,47	0,57	0,67	0,76	0,87
	1600	0,00	0,10	0,20	0,31	0,42	0,52	0,64	0,74	0,85	0,96
	1800	0,00	0,12	0,23	0,35	0,47	0,59	0,72	0,83	0,96	1,08
	2000	0,00	0,13	0,25	0,39	0,53	0,65	0,80	0,93	1,06	1,21
	2200	0,00	0,14	0,28	0,43	0,58	0,72	0,88	1,02	1,17	1,33
2400	0,00	0,16	0,31	0,46	0,63	0,78	0,96	1,11	1,27	1,45	
2600	0,00	0,17	0,33	0,50	0,68	0,85	1,04	1,21	1,38	1,57	
2800	0,00	0,18	0,36	0,54	0,74	0,91	1,12	1,30	1,49	1,69	
2880	0,00	0,19	0,37	0,56	0,76	0,94	1,15	1,34	1,53	1,74	
3000	0,00	0,20	0,38	0,58	0,79	0,98	1,20	1,39	1,59	1,81	
3200	0,00	0,21	0,41	0,62	0,84	1,04	1,28	1,48	1,70	1,93	
3400	0,00	0,22	0,43	0,66	0,90	1,11	1,36	1,58	1,81	2,05	
3600	0,00	0,24	0,46	0,70	0,95	1,17	1,44	1,67	1,91	2,17	
3800	0,00	0,25	0,48	0,74	1,00	1,24	1,52	1,76	2,02	2,29	
4000	0,00	0,26	0,51	0,77	1,05	1,31	1,60	1,85	2,12	2,41	















# DRIVE INSTALLATION INSTRUCTIONS

## SHAFT ALLOWANCE:

During installation, the belt should never be forced over the pulley edges. To install correctly the belt, reduce the centre distance and fit the belt without any tension. The required allowance to move one of the axis is determined in the following table:

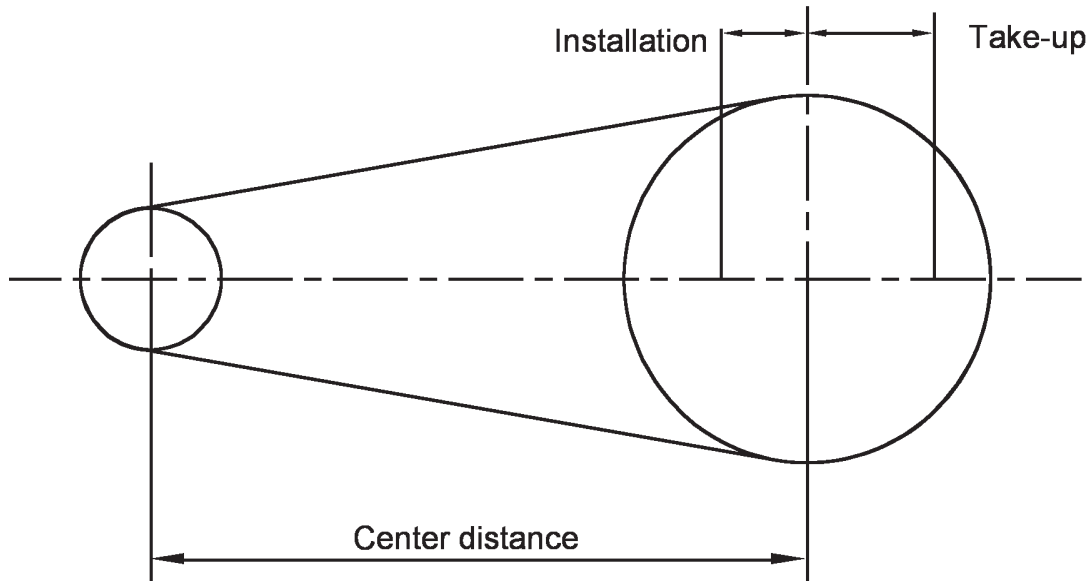

Belt length [mm]	Installation [mm]				Take-up [mm]
	PH, PTB2 & PJ	PK	PL	PM	
< 750	9	11			13
751-1000	10	12	25		16
1001-1250	12	12	25		20
1251-1500	14	16	25		20
1501-1750	16	16	25		25
1751-2000	18	16	25		25
2001-2250	20	23	25		30
2251-2500	22	23	25	40	30
2501-3000		23	30	40	35
3001-4000		23	30	45	45
4001-5000			35	45	55
5001-6000			35	50	65
6001-7500				55	85
7501-9000				60	100
9001-10500				65	115
10501-12000				75	130
12001-13500				80	150
13501-15000				90	165

TABLE 16: Installation and take-up values

## PULLEY ALIGNMENT

### Shaft parallelism:

Horizontal angle between PV pulleys: < 2 [°]  
 Horizontal angle between flat pulleys: < 1 [°]

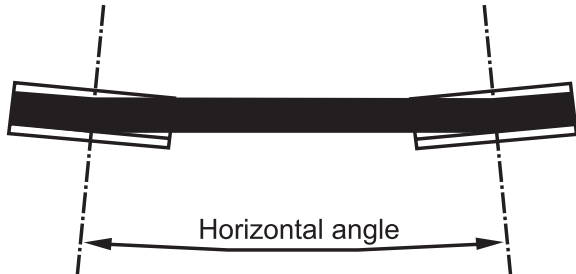

### Pulley misalignment:

Acceptable misalignment: < 3 [mm/m]  
 Maximum allowed misalignment: 15 [mm]

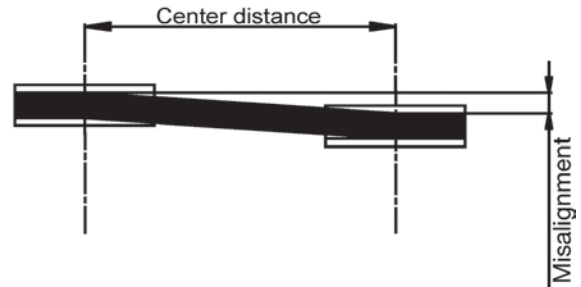

### Belt tension control:

#### Tension control by vibration method



$$T_s = 4 \cdot m \cdot t^2 \cdot fr^2$$

$$fr = \sqrt{\frac{T_s}{4 \cdot m \cdot t^2 \cdot z}}$$

Where:

$T_s$  = Static belt tension (See p.12) [N/span]  
 $m$  = Specific belt mass [kg/(rib·m)]  
 $t$  = Free belt span length [m]  
 $fr$  = Natural vibration frequency [Hz]  
 $z$  = Number of ribs

#### Tension control by deflection

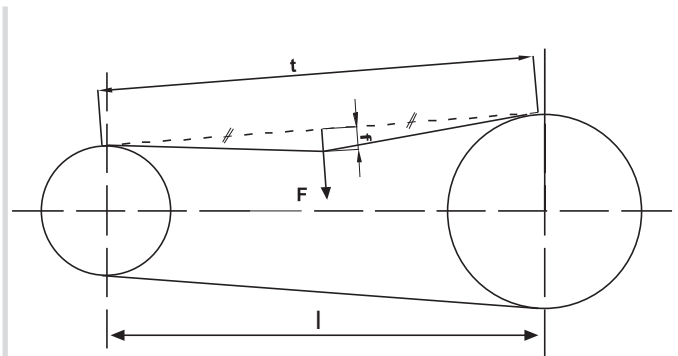

$$F_{min} = \frac{T_s}{16}$$

$$f = 0.015 \cdot t$$

$$F_{max} = \frac{1.5 \cdot T_s}{16}$$

$$t = \sqrt{l^2 - \frac{D-d}{2}^2}$$

Where:

$F$  = Perpendicular measuring force [N]  
 $T_s$  = Static belt tension. (See p.17) [N/span]  
 $f$  = Belt deflection [mm]  
 $t$  = Free span length [mm]  
 $l$  = Centre distance [mm]  
 $D$  = Diameter of large pulley [mm]  
 $d$  = Diameter of small pulley [mm]

After an initial running period of approx. 30 minutes under full load, installation tension must be checked and adjusted to initial value if necessary.



# POLY-V ELASTIC BELTS

## FIELDS OF APPLICATIONS

---

- Agricultural machinery
- Air conditioners
- Automatic doors
- Cement mixers
- Compressors
- Concrete cutting saw
- Cooling plants
- Dryers
- Electric generators
- Exercise bicycle
- Floor polisher
- Food mixers
- Food processors
- Grinders
- Lawn mowers
- Optical machinery
- Rollers
- Scooter
- Treadmill
- Vacuum cleaners
- Washing machines
- Wood planers / sanders
- Woodworking machinery

## BELT STRUCTURE

---

- Elastic polyamidic cord
- Each elastic belt is engineered for each transmission
- Standard poly-V pulleys are used
- Possible in rubber H and J pitches and in polyurethane H, TB2 and J pitches
- High flexibility



ELONGATION:  
RUBBER PV: FROM 2% TO 8%  
POLYURETHANE PV: FROM 4% TO 6%

## TENSION STABILITY

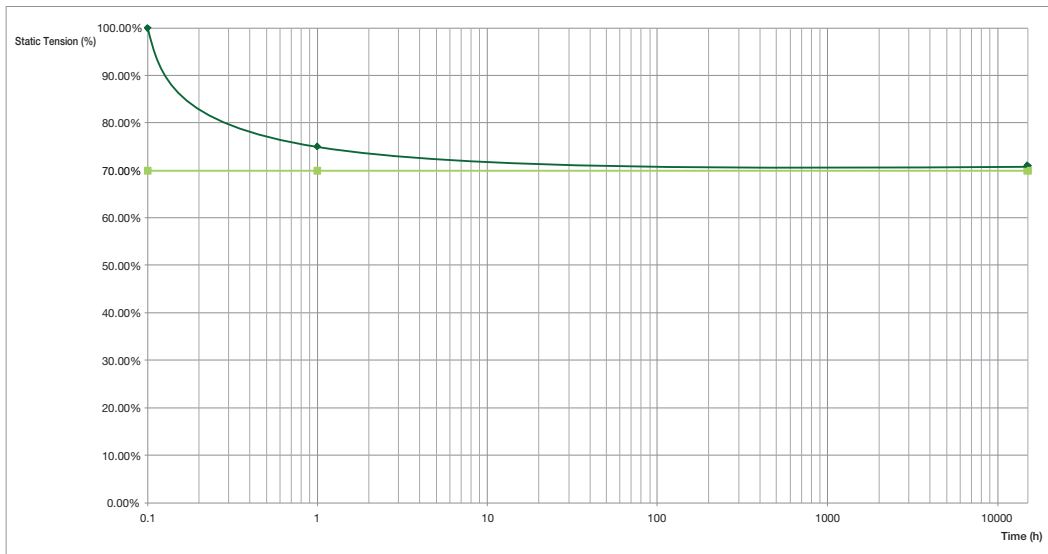

Under normal conditions, static tension fall is quite fast (some minutes). After this initial fall the static tension is stable. Please note that this fall is fairly high (30% - 40% than the initial static load).

## ADVANTAGES

- No need for tensioning devices compact drive
- Reduced transmissions costs
- Lower noise level
- Reduced vibrations
- Easier and reduced maintenance

## ASSEMBLY

In most cases elastic PV belts can be mounted without removing the pulleys.



please contact our OEM Team for a complete study of a Megadyne elastic PV belt.

## TABLE: LENGHT TOLERANCES

### RUBBER PV BELTS

Effective length L [mm]	Length tolerance [mm]				
	PH	PJ	PK	PL	PM
200<L≤500	-8/+4	-8/+4	-8/+4		
500<L≤750	-10/+5	-10/+5	-10/+5	-10/+5	
750<L≤1000	-12/+6	-12/+6	-12/+6	-12/+6	
1000<L≤1500	-16/+8	-16/+8	-16/+8	-16/+8	
1500<L≤2000	-20/+10	-20/+10	-20/+10	-20/+10	
2000<L≤3000		-24/+12	-24/+12	-24/+12	-24/+12
3000<L≤4000				-30/+15	-30/+15
4000<L≤6000				-40/+20	-40/+20
6000<L≤8000				-60/+30	-60/+30
8000<L≤12500					-90/+45
12500<L≤17000					-120/+60
Tension F per rib [N]	30	50	100	200	450
Measuring pulley external circumference [mm]	100/300	100/300	300	500	800

### POLYURETHANE PV BELTS

Effective length L [mm]	Length tolerance [mm]		
	PH	PTB2	PJ
Up to 1000	-10/+5	-5/+3	-5/+3
Above 1000	-10/+5	-10/+5	-10/+5
Tension F per rib [N]	25	30	40
Measuring pulley external diameter [mm]	31,85	31,85	31,85

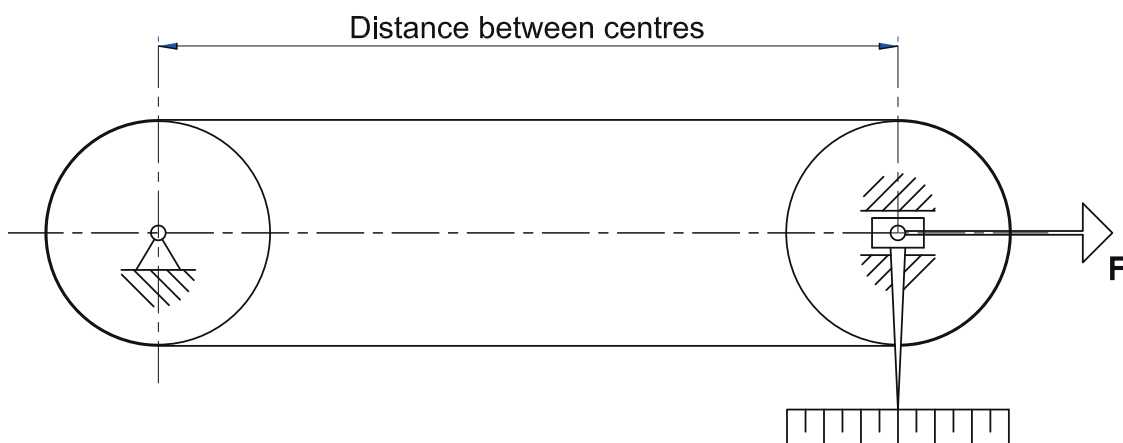

The effective length is verified placing the belt on two equal pulleys having same groove profile. The specified measuring tension F is applied to the shaft of one pulley.

## USEFUL FORMULAS

FORMULAS	DEFINITION	COMMENTS
$P_c = P \cdot F_s$	Design Power	
$i = \frac{n}{N} \geq 1$	Speed Ratio	$N = \frac{n \cdot d_p}{D_p}$
$d_p = d_{out} + (2 \cdot h)$	Small pulley's pitch diameter	For grooved pulleys
$D_p = D_{out} + 2 \cdot (h + h_r)$	Small pulley's pitch diameter	For flat pulleys
$v = \frac{\pi \cdot d_p \cdot n}{60000}$	Belt linear speed	
$L = 2l + 1.57 \cdot (D_p + d_p) + \frac{(D_p - d_p)^2}{4l}$	Pitch belt length	
$L_r = L_p - 2 \cdot h \cdot \pi$	Effective belt length	
$\beta = 180 - 57 \cdot \frac{D_p - d_p}{l_r}$	Arc of contact	
$P_r = (P_b + P_a) \cdot C_\beta \cdot C_L$	Corrected power rating per rib	
$z = \frac{P_c}{P_r}$	Number of ribs	
$T_s = \frac{500 \cdot (2.5 - C_\beta) \cdot P_c}{C_\beta \cdot v} + m \cdot z \cdot v^2$	Static tension of the span	
$F_{shaft,d} = \sqrt{\frac{T_e^2}{2} + 2 \cdot T_s^2 - 2 \cdot \cos \beta \cdot \left( T_s^2 - \frac{T_e^2}{4} \right)}$	Shaft dynamic load	$T_e = \frac{1000 \cdot P}{v}$

The data and information contained in the present catalogue are up-to-dated to the date of the catalogue's printing. Megadyne Spa reserves the right to modify the specifications, performances and other information relating to the belts described in the present catalogue, at any time at its own discretion, without any prior notice. For updating refer to our web site [www.megadynegroup.com](http://www.megadynegroup.com).

Technical specifications, performances and other information provided in the present catalogue are indicative and do not bound Megadyne unless such specifications, performances or other information are expressly agreed in the agreement with the customer.

We also recommend to read carefully the following documents in our web site [www.megadynegroup.com](http://www.megadynegroup.com):

- Megadyne General Conditions of Sale (comprising the warranty)
  - Theoretical Belt Life
  - Drive Components: Storage, Installation, Maintenance and Troubleshooting Handbook - Belts standard use condition and temperature.
- Copyright Notice: Megadyne Spa copyright. All rights reserved. Megadyne is and shall remain the owner of all rights on drawings, technical specifications and any other information contained in the present catalogue or otherwise communicated by Megadyne Spa to the customer. The customer shall not disclose such information to third parties or use such information for purposes different from the definition of the order to Megadyne Spa, unless upon prior written authorization of Megadyne.



MEGADYNE S.p.A.  
ITALY - MATHI



ISO 9001:2008 - ISO 14001:2004  
MEGADYNE RUBBER S.A.

**AUSTRALIA****Victoria**

Phone +61 (03) 9763 6701  
 au-ptsales@ammega.com

**BELARUS****Minsk**

Phone +375 17 2802486  
 Info.by@megadynegroup.com

**BRASIL****Sorocaba**

Phone +55 15 2101 7700  
 Info.br@megadynegroup.com

**CANADA****Edmonton**

Phone +1 780 461 4400  
 Info.ca@megadynegroup.com

**Montreal**

Phone +1 514 695 1313  
 Info.ca@megadynegroup.com

**Toronto**

Phone +1 905 602 4400  
 Info.ca@megadynegroup.com

**CHINA****Beijing**

Phone +86 10 8150 7478  
 info.cn@megadynegroup.com

**Foshan**

Phone +86 757 8381 5530  
 info.cn@megadynegroup.com

**Ningbo\***

Phone +86 574 8650 5008  
 info.cn@megadynegroup.com

Phone +86 574 8833 4378  
 sales@challengept.com

**Qingdao\***

Phone +86 532 8658 0951  
 info.cn@megadynegroup.com

**Shanghai**

Phone +86 21 5447 1473  
 info.cn@megadynegroup.com

**Xi'an**

Phone +86 29 86358108  
 info.cn@megadynegroup.com

**COLOMBIA****Bogotá**

Phone +57 (1) 471 0503  
 Phone +57 (1) 893 9890  
 Info.co@megadynegroup.com

**Cartagena**

Phone +57 (5) 669 3604  
 Info.co@megadynegroup.com

**CZECH REPUBLIC****Prague**

Phone +420 603 461 892  
 Info.cz@megadynegroup.com

**FRANCE****Paris**

Phone +33 1 6079 8200  
 info.fr@megadynegroup.com

**GERMANY****Borchen**

Phone +49 5251 8735 0  
 info.de@megadynegroup.com

**HUNGARY****Budapest**

Phone +36 23 428 628  
 info.hu@megadynegroup.com

**INDIA****Chennai\***

Phone +91 98841 81175  
 info.in@megadynegroup.com

**IRELAND****Dublin**

Phone +353 1 456 6311  
 ireland@challengept.com

**ISRAEL****Caesarea**

Phone +972 4 637 1485  
 info.il@megadynegroup.com

**ITALY****Turin\***

Phone +39 011 926 8052  
 info@megadynegroup.com

**Pescara\***

Phone +39 085 9700547  
 info.it@megadynegroup.com

**Venice**

Phone +39 041 929 367  
 info.it@megadynegroup.com

**JAPAN****Nagoya**

Phone +81 52 433 7400  
 info.jp@megadynegroup.com

**MEXICO****Mexico C.P.**

Phone +52 55 5587 3680  
 info.mx@megadynegroup.com

**PERU****Lima**

Phone +51 713 0069  
 info.pe@megadynegroup.com

**POLAND****Bielsko Biala**

Phone +48 32 447 7179  
 info.pl@megadynegroup.com

**Bydgoszcz\***

info.pl@megadynegroup.com

**SINGAPORE****Singapore**

Phone +65 62739767  
 Info.sg@megadynegroup.com

**SOUTH AFRICA****Johannesburg**

Phone +27 (0) 12 661 1652  
 info.za@megadynegroup.com

Phone +27 (0) 11 3976115  
 sasales@challengept.com

**Cape Town**

Phone +27 (0)21 9820772  
 info.za@megadynegroup.com

**SOUTH KOREA****Gyeonggi-do**

Phone +82 314483613-7  
 Info.kr@megadynegroup.com

**SPAIN****Vilanova\***

Phone +34 93 811 5450  
 info.es@megadynegroup.com

**SWEDEN****Kristianstad**

Phone +46 10 1309600  
 info.se@megadynegroup.com

**THAILAND****Bangkok**

Phone +66 2 902260413  
 info.th@megadynegroup.com

**TURKEY****Izmir**

Phone +90 232 877 07 00  
 info.tr@megadynegroup.com

**U.K.****Birmingham**

Phone +44 1384 215 021  
 info.uk@megadynegroup.com

**Wolverhampton**

Phone +44 (0) 1902 866116  
 uksales@challengept.com

**U.S.A****California**

Phone +1 323 265 8061  
 info.us@megadynegroup.com

**Florida**

Phone +1 813 241 4111  
 info.us@megadynegroup.com

**Georgia\***

info.us@megadynegroup.com

**Illinois**

Phone +1 630 752 0600  
 info.us@megadynegroup.com

**New Jersey Americas HQ**

Phone +1 973 227 4904  
 info.us@megadynegroup.com

**North Carolina\***

info.us@megadynegroup.com

**Oregon**

Phone +1 503 231 7224  
 info.us@megadynegroup.com

**Texas**

Phone +1 972 438 6992  
 info.us@megadynegroup.com

**\* Manufacturing locations****GENERAL CONTACT INFORMATION****MEGADYNE**

Via S. Lucia, 114  
 10075 Mathi (Torino)

Phone +39 011 926 8052  
 info@megadynegroup.com

ammega.com